



Large Aperture Rotary Stage

ALAR-XP

Maximum Torque & Smooth Motion for Ultra-Heavy Duty Applications

The ALAR family of direct-drive, large-aperture rotary stages provides superior angular positioning and velocity control. ALAR-XP offers extremely high torque output, substantial load capacity and smooth, precise rotation. Featuring a large-diameter clear aperture and a non-cogging direct-drive motor, ALAR-XP stages offer a superior alternative to worm-gear stages.

Key Applications

ALAR-XP stages are best suited for applications including:

- ◆ Single- and multi-axis sensor testing
- ◆ Inertial navigation device qualification
- ◆ Missile seeker testing
- ◆ Antenna testing
- ◆ Opto-electronics alignment and testing
- ◆ High-accuracy laser processing
- ◆ Custom high-capacity gimbal assemblies



KEY FEATURES:

- ◆ Delivers **EXCEPTIONAL TORQUE OUTPUT** up to 1100 N·m to rotate high-inertia payloads with ease
- ◆ Achieves **EXTREMELY PRECISE, SMOOTH, COG-FREE ROTATION** with ironless direct-drive torque motor
- ◆ **SUPPORTS LARGE PAYLOADS** & gimbal configurations thanks to high axial-, radial- & moment-load capacities
- ◆ Available with clear aperture diameters of 250 mm & 325 mm for **SIMPLIFIED PROCESS INTEGRATION**
- ◆ Provides **LONG SERVICE LIFE** & consistent performance over time
- ◆ Available with absolute encoder option & limited travel for **MAXIMUM PAYLOAD SECURITY**

ALAR-XP SPECIFICATIONS

Mechanical Specifications	ALAR250XP-M1	ALAR250XP-M2	ALAR325XP-M1	ALAR325XP-M2
Travel	Continuous (optional 340° max. limited travel)			
Aperture	250 mm		325 mm	
Resolution (Min. Incremental Motion) ⁽¹⁾	0.05 μrad (0.01 arc sec)		0.04 μrad (0.009 arc sec)	
Accuracy ⁽²⁾⁽³⁾	± 9.7 μrad (± 2 arc sec)			
Bidirectional Repeatability ⁽³⁾	± 2.4 μrad (± 0.5 arc sec)			
Tilt-Error Motion	9.7 μrad (2.0 arc sec)			
Maximum Speed ^(4,5)	180 rpm		100 rpm	
Maximum Torque	548.6 N•m	731.5 N•m	833.0 N•m	1110.7 N•m
Continuous Torque	64.2 N•m	85.6 N•m	107.4 N•m	143.1 N•m
Axial Load	4950 N		5825 N	
Radial Load	5200 N		6650 N	
Moment Load	1825 N•m		2650 N•m	
Shaft Inertia	0.89 kg•m ²		1.71 kg•m ²	
Shaft Inertia with Limits	0.96 kg•m ²		1.82 kg•m ²	
Stage Mass	100 kg	104 kg	125 kg	130 kg
Stage Mass with Limits	104 kg	108 kg	129 kg	134 kg

1. Resolution assumes -AS encoder with 2000x controller multiplication.
2. Certified with each stage. Requires the use of an Aerotech controller.
3. Repeatability and accuracy are dependent on encoder selection. To achieve the listed specifications, the electrical resolution should be 0.2 arc sec or smaller.
4. Maximum speed assumes a bus voltage of 320 VDC.
5. Digital RS422 encoder options will limit maximum speed below the listed value. Contact factory for specific stage and encoder speed combination.

Electrical Specifications	ALAR250XP-M1	ALAR250XP-M2	ALAR325XP-M1	ALAR325XP-M2	
Motor	Brushless Slotless				
Continuous Current	A _{pk}	11.2	14.9	11.3	15.1
	A _{rms}	7.9	10.6	8.0	10.7
Peak Current, Stall	A _{pk}	95.7	127.6	87.8	117.1
	A _{rms}	67.7	90.2	62.1	82.8
Bus Voltage	Up to 340 VDC				
Incremental Encoder Line Count	64,800 lines/rev		76,800 lines/rev		
Limit Switches ⁽¹⁾	5 V, normally closed				

1. Limited travel options only.

ALAR-XP ORDERING INFORMATION

ALAR-XP Mechanical-Bearing, Direct-Drive Rotary Stage

ALAR250XP Mechanical-bearing, direct-drive rotary stage, high torque, 250 mm aperture

ALAR325XP Mechanical-bearing, direct-drive rotary stage, high torque, 325 mm aperture

Motor (Required)

-M1 Standard motor

-M2 High-power motor

Travel (Required)

- Continuous travel

-TR010 Limited travel, ± 5 degrees

-TR020 Limited travel, ± 10 degrees

-TR030 Limited travel, ± 15 degrees

-TR060 Limited travel, ± 30 degrees

-TR090 Limited travel, ± 45 degrees

-TR120 Limited travel, ± 60 degrees

-TR180 Limited travel, ± 90 degrees

-TR240 Limited travel, ± 120 degrees

-TR300 Limited travel, ± 150 degrees

-TR340 Limited travel, ± 170 degrees

Feedback (Required)

-E1 Incremental encoder, 1 Vpp

-E2 Incremental encoder, digital RS422, x200 interpolation

-E3 Absolute encoder

Integration (Required)

Aerotech offers both standard and custom integration services to help you get your system fully operational as quickly as possible. The following standard integration options are available for this system. Please consult Aerotech if you are unsure what level of integration is required, or if you desire custom integration support with your system.

-TAS Integration - Test as system

Testing, integration, and documentation of a group of components as a complete system that will be used together (ex: drive, controller, and stage). This includes parameter file generation, system tuning, and documentation of the system configuration.

-TAC Integration - Test as components

Testing and integration of individual items as discrete components that ship together. This is typically used for spare parts, replacement parts, or items that will not be used together. These components may or may not be part of a larger system.

ALAR-XP DIMENSIONS

ALAR250XP

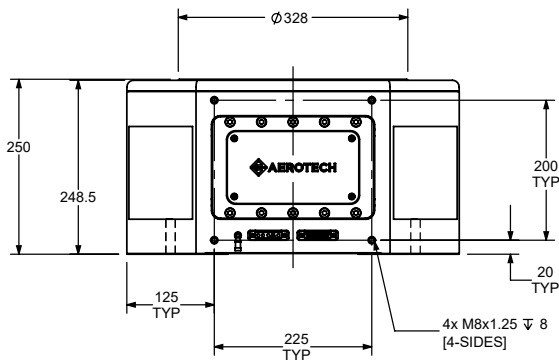
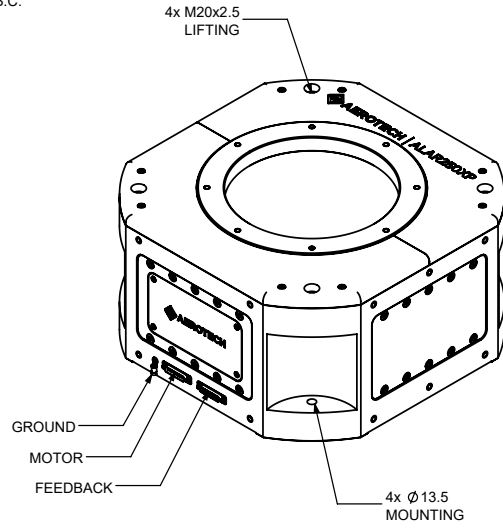
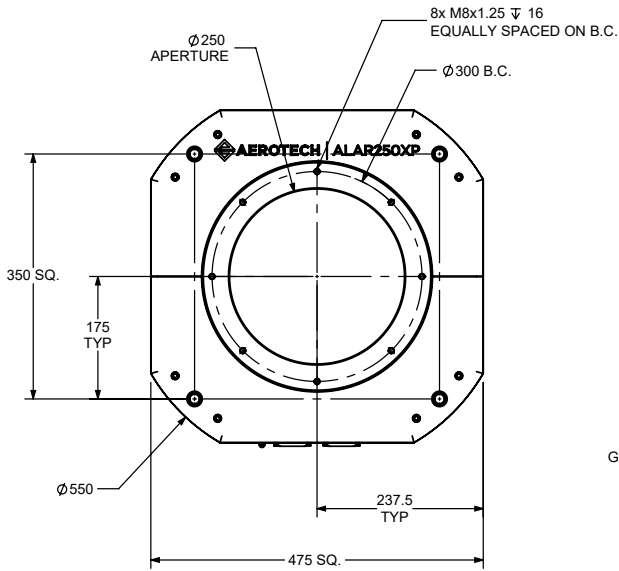

CONTINUOUS TRAVEL

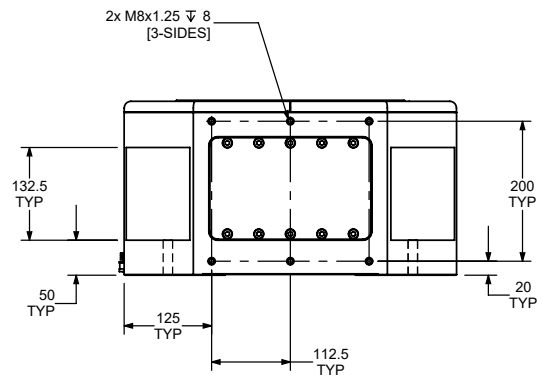

LIMITED TRAVEL (-TRxxx)
(NOT A PROJECTED VIEW)

DIMENSIONS: MILLIMETERS

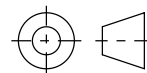

ALAR-XP DIMENSIONS

ALAR325XP

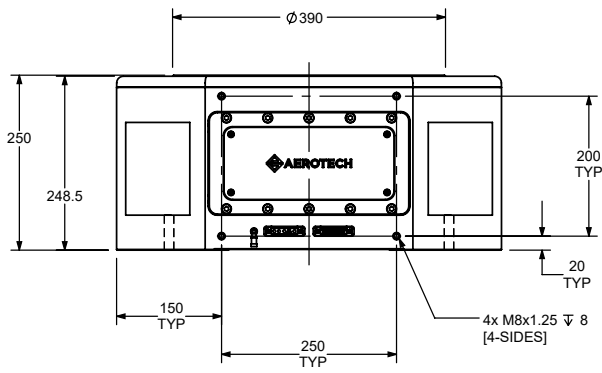
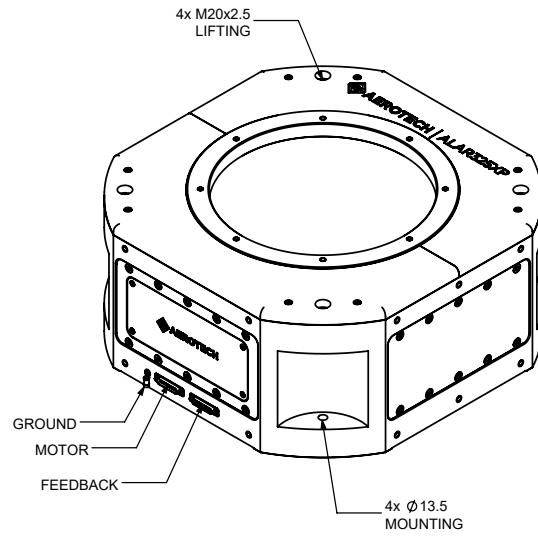
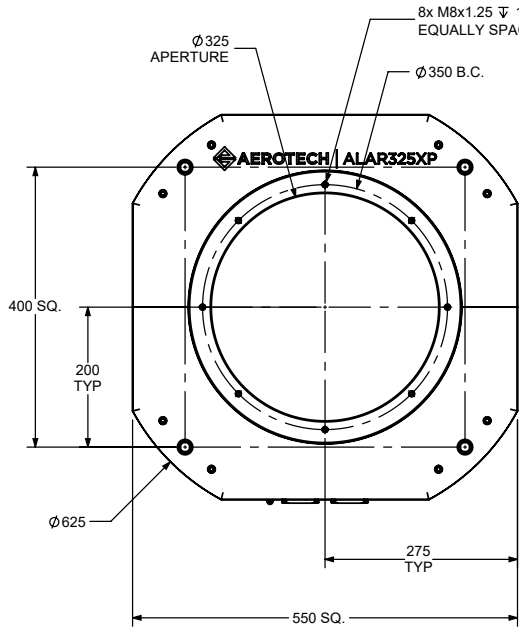

CONTINUOUS TRAVEL

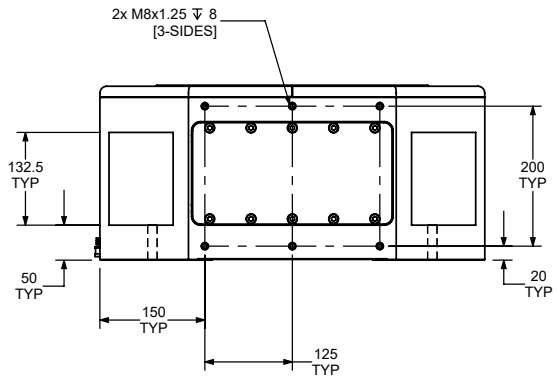

LIMITED TRAVEL (-TRxxx)
(NOT A PROJECTED VIEW)

DIMENSIONS: MILLIMETERS

