

ABRT Series Stage

User's Manual

P/N: EDS126 (Revision 1.04.00)



Dedicated to the Science of Motion
Aerotech, Inc.
101 Zeta Drive,
Pittsburgh, PA, 15238
Phone: 412-963-7470
Fax: 412-963-7459
www.aerotech.com



Product Registration

Register online at: <http://www.aerotech.com/prodreg.cfm>

Technical Support

United States Headquarters:

Phone: (412) 967-6440

Fax: (412) 967-6870

Email: service@aerotech.com

United Kingdom:

Phone: +44 118 940 9400

Fax: +44 118 940 9401

Email: service@aerotech.co.uk

Germany:

Phone: +49 911 967 9370

Fax: +49 911 967 93720

Email: service@aerotechgmbh.de

Japan:

Phone: +81(0)47-489-1741 (Sales)

Phone: +81(0)47-489-1742 (Service)

Fax: +81(0)47-489-1743

Email: service@aerotechkk.com.jp

China:

Phone: +852-3793-3488

Email: saleschina@aerotech.com

Revision History

Revision 1.04.00	April 5, 2011
Revision 1.03.00	June 10, 2009
Revision 1.02.00	January 5, 2009
Revision 1.01.00	March 10, 2008
Revision 1.00.00	September 4, 2007

Table of Contents

Table of Contents.....	iii
List of Figures.....	v
List of Tables.....	vii
Chapter 1: Overview.....	1
1.1. Standard Features.....	1
1.1.1. Optional Features.....	1
1.1.2. Model Numbers.....	2
1.2. Dimensions.....	3
1.3. Safety Procedures and Warnings.....	6
1.4. EC Declaration of Incorporation.....	8
Chapter 2: Installation.....	9
2.1. Unpacking and Handling the Stage.....	9
2.2. Preparing the Mounting Surface.....	10
2.3. Securing the Stage to the Mounting Surface.....	11
2.4. Attaching the Payload to the Stage.....	13
2.5. Electrical Installation.....	14
2.6. Air Requirements.....	15
Chapter 3: Operating Specifications.....	17
3.1. Environmental Specifications.....	17
3.2. Basic Specifications.....	18
3.3. Load Capability.....	21
3.4. Limit Switch Wiring.....	21
3.5. Standard Motor Wiring.....	22
3.6. Vacuum Operation.....	24
Chapter 4: Maintenance.....	25
4.1. Service and Inspection Schedule.....	25
4.1.1. Field Service.....	25
4.2. Cleaning and Lubrication.....	25
4.2.1. Recommended Cleaning Solvents.....	25
Appendix A: Warranty and Field Service.....	27
Appendix B: Technical Changes.....	29
Index.....	31
Reader's Comments.....	33

List of Figures

Figure 1-1: Standard ABRT-200 Rotary Stage.....	1
Figure 1-2: ABRT-150 Dimensions.....	3
Figure 1-3: ABRT-200 Dimensions.....	4
Figure 1-4: ABRT-260 Dimensions.....	5
Figure 2-1: Results of Flat Versus Non-Flat Mounting.....	10
Figure 2-2: Top View of an ABRT-200P Stage Showing Mounting Holes.....	11
Figure 2-3: Side View of an ABRT-200 Stage Showing Tapped Mounting Holes.....	12

List of Tables

Table 1-1: Model Numbering System	2
Table 3-1: Environmental Specifications.....	17
Table 3-2: ABRT Series Specifications.....	18
Table 3-3: ABRT Series Resolution Information.....	19
Table 3-4: ABRT Series Maximum Encoder Frequency.....	19
Table 3-5: ABRT Series Motor Specifications.....	20
Table 3-6: ABRT Series Load Capability.....	21
Table 3-7: Standard Wiring Connectors for ABRT-200MP, -250MP, and -300MP Stages.....	22
Table 3-8: Special Feedback Cable with Encoder Interface Box.....	23
Table 3-9: Motor Wiring Pinout Descriptions.....	24
Table B-1: Current Changes (1.04.00).....	29
Table B-2: Archived Changes.....	30

Chapter 1: Overview

This chapter introduces standard and optional features of the ABRT stages, explains the model numbering system, and gives general safety precautions.

1.1. Standard Features

All ABRT stages incorporate completely non-contact air bearing surfaces, direct drive brushless motors and feedback devices to provide a completely maintenance free stage. There is no mechanical contact to become worn or require lubrication, making these stages ideal for clean room and medical applications.

The ABRT features large air-bearing surfaces and active preloading for high stiffness and load capacity. The direct drive design is optimum for continuous production environments due to the maintenance free design of the motor. The direct drive and slotless motor design combine to create outstanding velocity control. This is especially useful in scanning applications where a torque ripple cannot be tolerated.

1.1.1. Optional Features

All AABRT stages incorporate a center aperture, ranging in size from 20 mm to 50 mm diameter. The tabletops can be built with either metric or custom hole patterns depending on requirements.

Additionally, the encoder can be configured for either square-wave or amplified sine output.

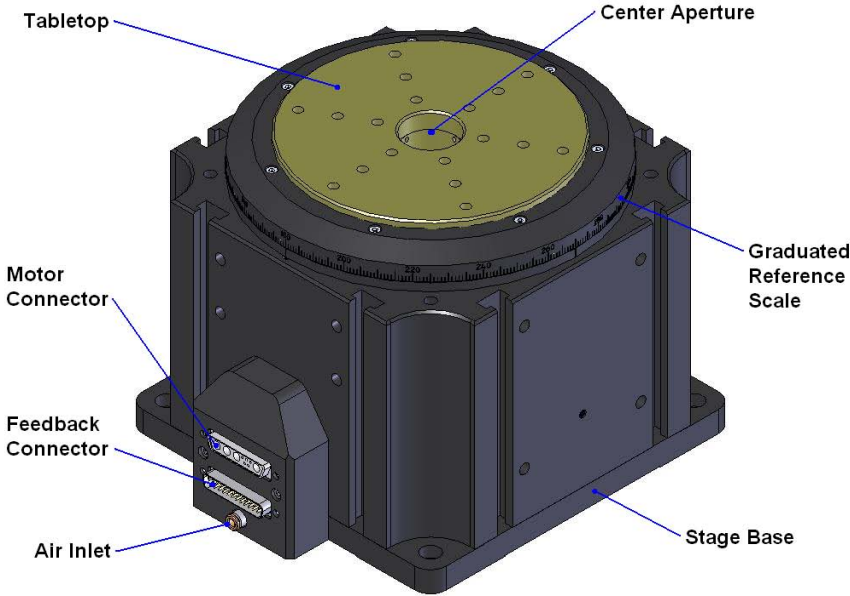

Figure 1-1: Standard ABRT-200 Rotary Stage

1.1.2. Model Numbers

The stage model number indicates the optional features on a particular stage. To determine the options on your stage, refer to Table 1-1 for an explanation of the numbering system.

Example: ABRT-150-AS

This designates an ABRT-150 stage with direct drive motor and 1vpp sine wave encoder.

Aerotech continually improves its product offerings, and listed options may be superseded at any time. Refer to the most recent edition of the Aerotech Motion Control Product Guide for the most current product information at www.aerotech.com.

Table 1-1: Model Numbering System

ABRT Series Direct Drive Rotary Stage	
ABRT-150	150 mm wide air-bearing rotary stage with 1.4 N-m peak torque output
ABRT-200	200 mm wide air-bearing rotary stage with 14.6 N-m peak torque output
ABRT-260	260 mm wide air-bearing rotary stage with 26.6 N-m peak torque output
Mounting Pattern	
-M	Metric dimension mounting pattern and holes
Position Transducer	
-AS	Standard feedback device, sine wave output; 11,840 cycles per rev on ABRT-150; 18,000 cycles per rev on ABRT-200; 23,600 cycles per rev on ABRT-260
-X50	Square wave digital output; 592,000 cycles per rev on ABRT-150; 900,000 cycles per rev on ABRT-200; 1,180,000 cycles per rev on ABRT-260
Note: Digital output encoder signals are synthesized with a 40 MHz clock. Care must be taken to ensure that the encoder sample rate on the controller is at least 40 MHz or higher. Slower clock rates are available on request.	

1.2. Dimensions

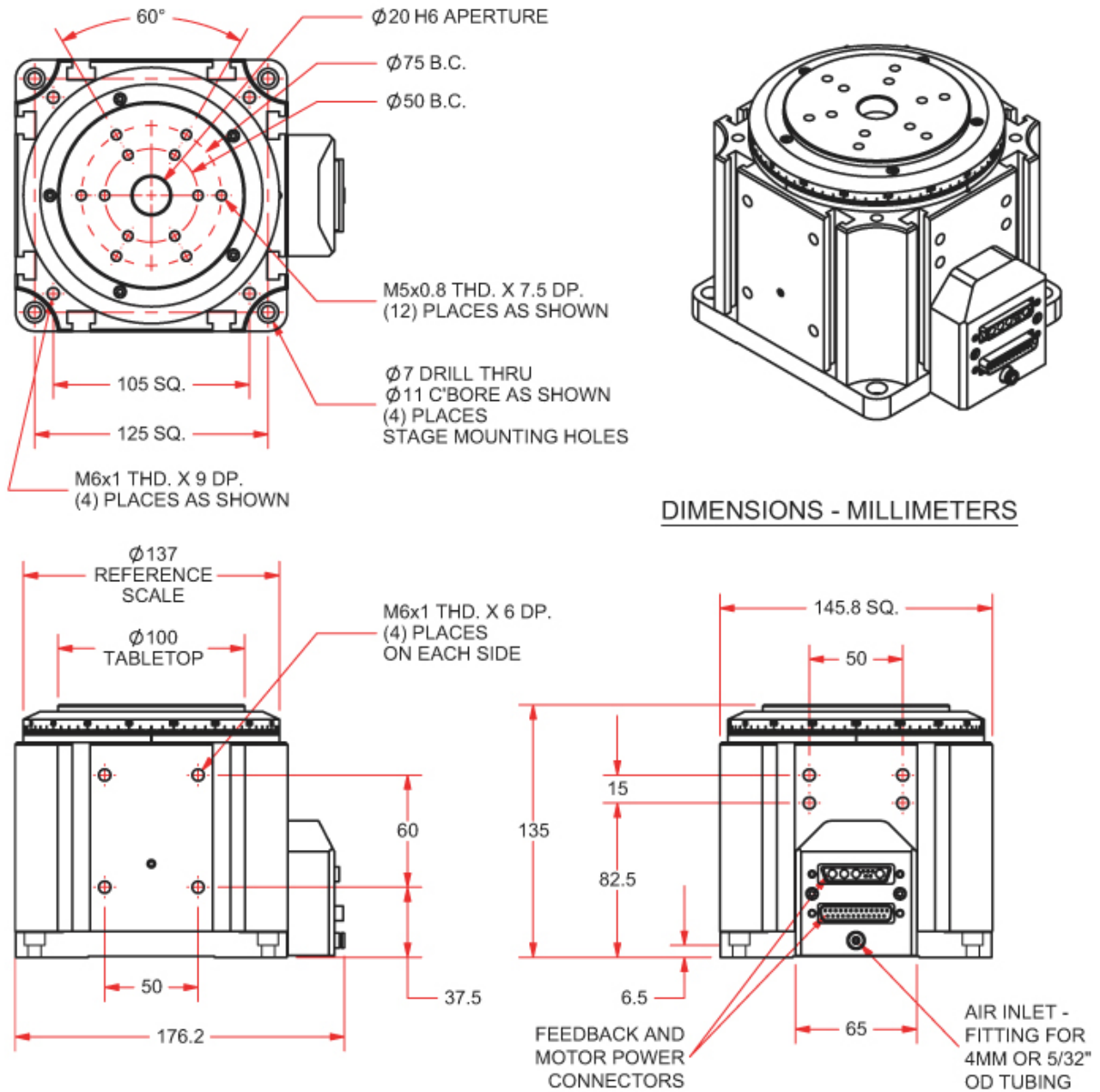

Figure 1-2: ABRT-150 Dimensions

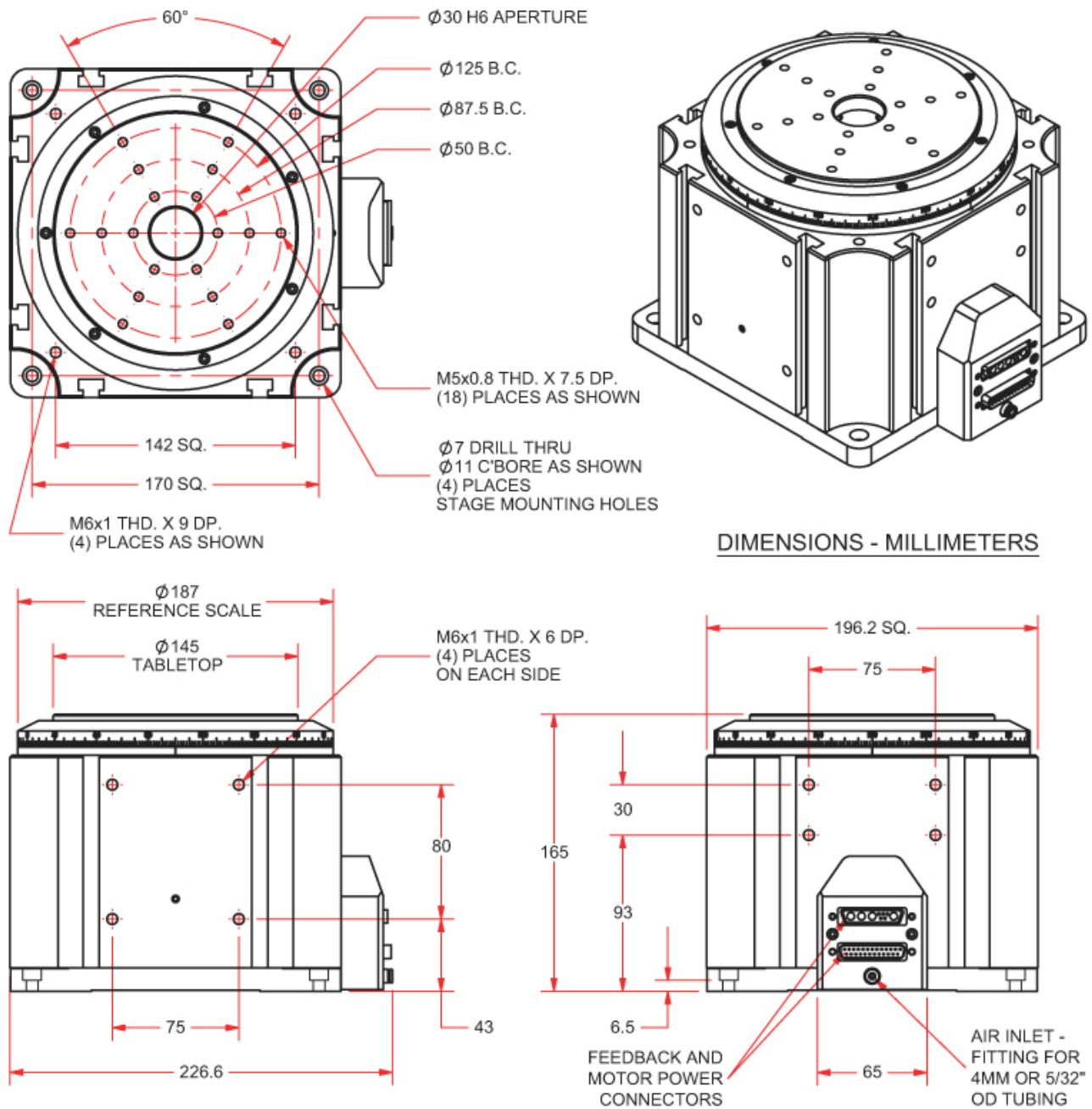

Figure 1-3: ABRT-200 Dimensions

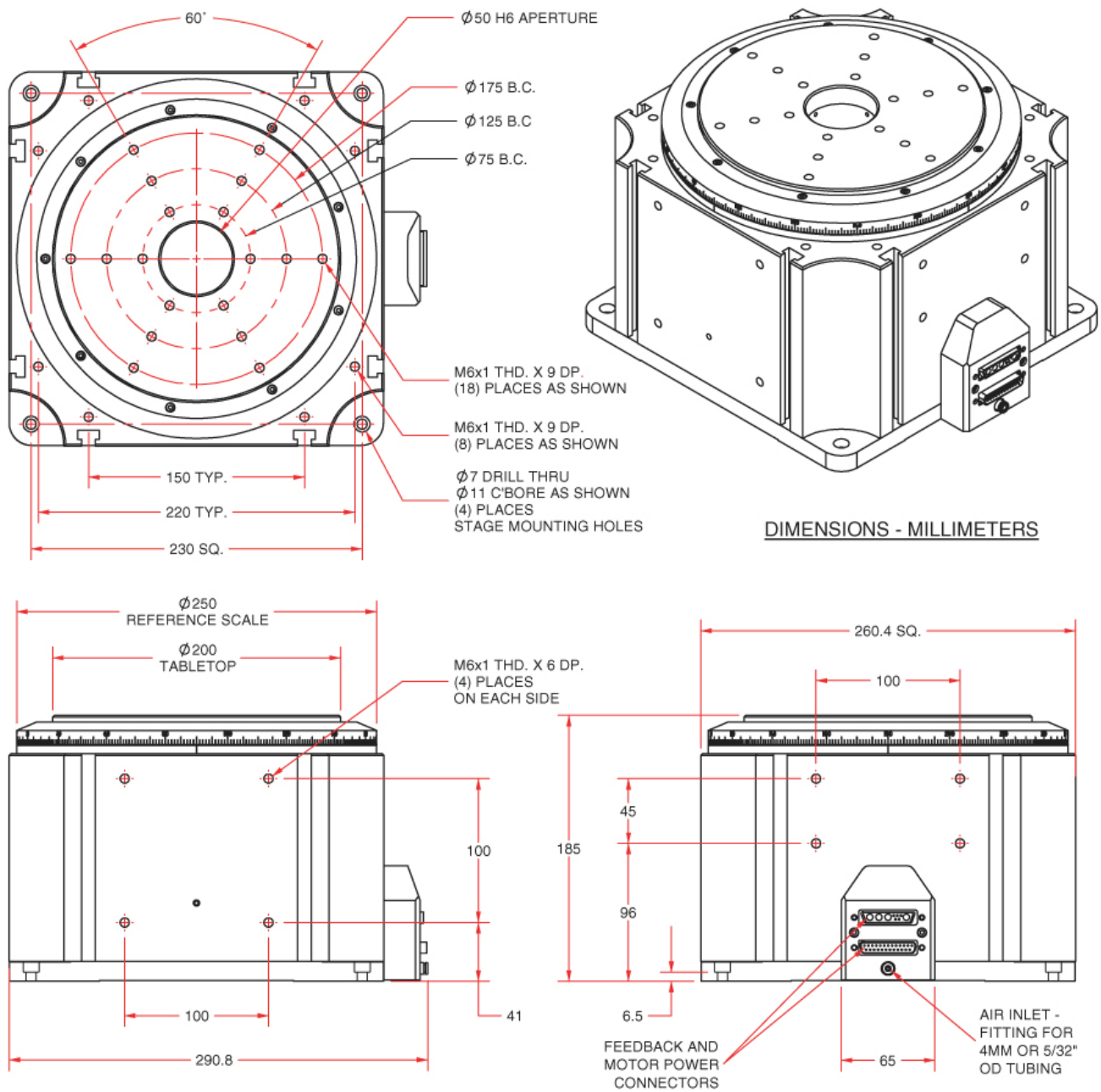

Figure 1-4: ABRT-260 Dimensions

1.3. Safety Procedures and Warnings

The following statements apply throughout this manual. Failure to observe these precautions could result in serious injury to those performing the procedures and damage to the equipment.

This manual and any additional instructions included with the stage should be retained for the lifetime of the stage.



DANGER

To minimize the possibility of electrical shock and bodily injury or death, disconnect all electrical power prior to making any electrical connections.



DANGER

To minimize the possibility of electrical shock and bodily injury or death when any electrical circuit is in use, ensure that no person comes in contact with the circuitry when the stage is connected to a power source.



DANGER

To minimize the possibility of bodily injury or death, disconnect all electrical power prior to making any mechanical adjustments.



DANGER

Moving parts of the stage can cause crushing or shearing injuries. All personnel must remain clear of any moving parts.



WARNING

Improper use of the stage can cause damage, shock, injury, or death. Read and understand this manual before operating the stage.



WARNING

If the stage is used in a manner not specified by the manufacturer, the protection provided by the stage can be impaired.



WARNING

Stage cables can pose a tripping hazard. Securely mount and position all stage cables to avoid potential hazards.



WARNING

Do not expose the stage to environments or conditions outside the specified range of operating environments. Operation in conditions other than those specified can cause damage to the equipment.



WARNING

The stage must be mounted securely. Improper mounting can result in injury and damage to the equipment.



WARNING

Use care when moving the stage. Manually lifting or transporting stages can result in injury.



WARNING

Only trained personnel should operate, inspect, and maintain the stage.



WARNING

This stage is intended for light industrial manufacturing or laboratory use. Use of the stage for unintended applications can result in injury and damage to the equipment.



WARNING

Before using this stage, perform an operator risk assessment to determine the needed safety requirements.

1.4. EC Declaration of Incorporation

Manufacturer: Aerotech, Inc.
101 Zeta Drive
Pittsburgh, PA 15238
USA



herewith declares that the product:

Aerotech, Inc. ABRT Stage

is intended to be incorporated into machinery to constitute machinery covered by the Directive 2006/42/EC as amended;

does therefore not in every respect comply with the provisions of this directive;

and that the following harmonized European standards have been applied:

EN ISO 12100-1,-2:2003+A1:2009

Safety of machinery - Basic concepts, general principles for design

ISO 14121-1:2007

Safety of machinery - Risk assessment - Part 1: Principles

EN 60204-1:2005

Safety of machinery - Electrical equipment of machines - Part 1: General requirements

and further more declares that

it is not allowed to put the equipment into service until the machinery into which it is to be incorporated or of which it is to be a component has been found and declared to be in conformity with the provisions of the Directive 2006/42/EC and with national implementing legislation, i.e. as a whole, including the equipment referred to in this Declaration.

This is to certify that the aforementioned product is in accordance with the applicable requirements of the following Directive(s):

2011/65/EU

RoHS 2 Directive

Authorized Representative: Manfred Besold
Address: AEROTECH GmbH
Süd-West-Park 90
D-90449 Nürnberg

Name:

Alex Weibel / 
Engineer Verifying Compliance

Position:

Location: Pittsburgh, PA

Date: April 5, 2011

Chapter 2: Installation

This chapter describes the installation procedure for the ABRT stage, including handling the stage properly, preparing the mounting surface to accept the stage, securing the stage to the mounting surface, attaching the payload, and making the electrical connections.



Installation must follow the instruction in this chapter. Failure to follow these instructions could result in injury and damage to the equipment.

2.1. Unpacking and Handling the Stage

Carefully remove the stage from the protective shipping container. Blow the stage off with compressed nitrogen or clean, dry air. Before operating the stage, it is important to let the stage stabilize at room temperature for at least 12 hours. Set the stage on a smooth, flat, and clean surface.

Before the stage can be operated, the shipping clamps must be removed. These are the only red anodized parts on the stage and must all be removed.

Each stage has a label listing the system part number and serial number. These numbers contain information necessary for maintaining or updating system hardware and software. Locate this label and record the information for later reference. If any damage has occurred during shipping, report it immediately.



Improper stage handling could adversely affect the stage's performance. Therefore, use care when moving the stage. Manually lifting or transporting the stage can cause injury.



Lift the stage only by the base. Do not use the tabletop or wiring connections to support the stage.



Do not attempt to rotate the stage table until the air supply, detailed in Section 2.6, has been installed. Moving the stage table without air supplied can cause permanent damage to the stage.

2.2. Preparing the Mounting Surface

The mounting surface should be flat and have adequate stiffness in order to achieve the maximum performance from the ABRT. When an ABRT series stage is mounted to a non-flat surface, the stage can be distorted as the mounting screws are tightened. This distortion will decrease the overall accuracy of the stage. *To maintain accuracy, the mounting surface should be flat within 2 μ m TIR.* Adjustments to the mounting surface must be done before the stage is secured. The effects of flatness on mounting are illustrated in Figure 2-1.

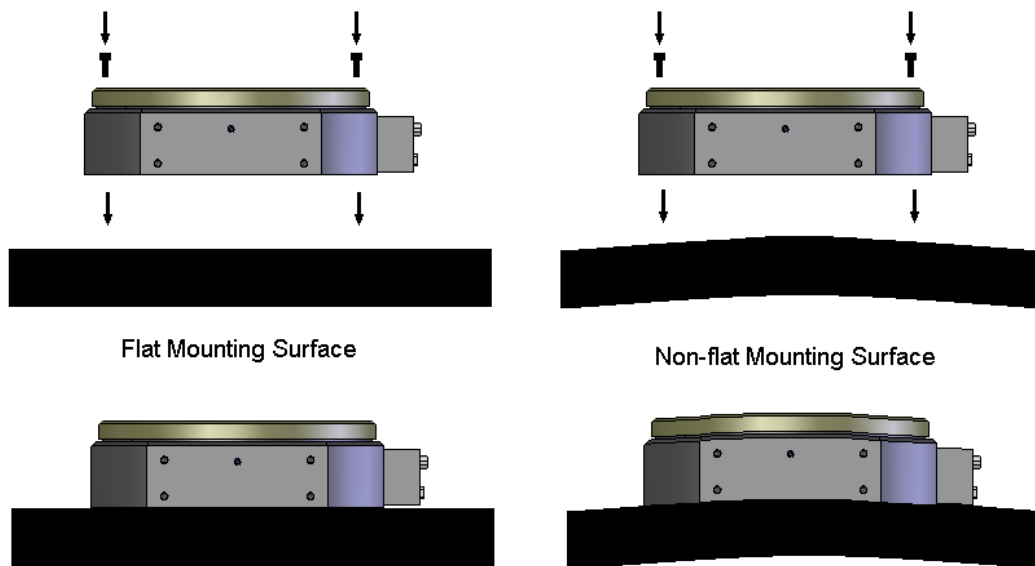

Figure 2-1: Results of Flat Versus Non-Flat Mounting

NOTE: The stage base is precision machined and verified for flatness prior to stage assembly at the factory. If machining is required to achieve the desired flatness, it should be performed on the mounting surface rather than the stage base. Shimming should be avoided if possible. If shimming is required, it should be minimized to improve the rigidity of the system.

It is recommended that the stage be mounted with the axis of rotation in the vertical direction. Mounting the stage with the axis of rotation in a horizontal orientation is generally acceptable as well, but this arrangement can potentially have a negative effect on performance. Please consult the factory for more information regarding stage performance in a horizontal axis of rotation configuration.

2.3. Securing the Stage to the Mounting Surface

ABRT series stages have counterbored mounting holes available to secure the stage to a mounting surface.

Figure 2-2 shows these mounting holes in the base of the stage. These counterbored holes are designed for 6mm socket head cap screws. Additionally, the sides of the stage are equipped with several M6x1.0 tapped holes with reinforced threaded inserts (see Figure 2-3). These tapped holes may also be used for mounting the stage, depending on customer requirements.



The stage must be mounted securely. Improper mounting can result in injury and damage to the equipment.

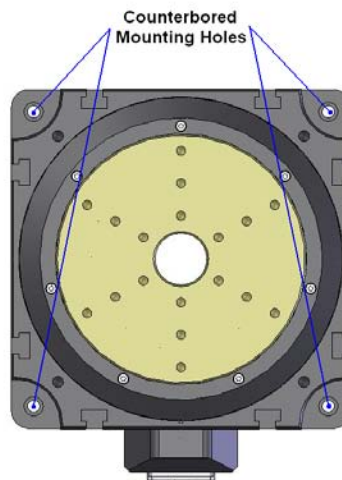

Figure 2-2: Top View of an ABRT-200P Stage Showing Mounting Holes

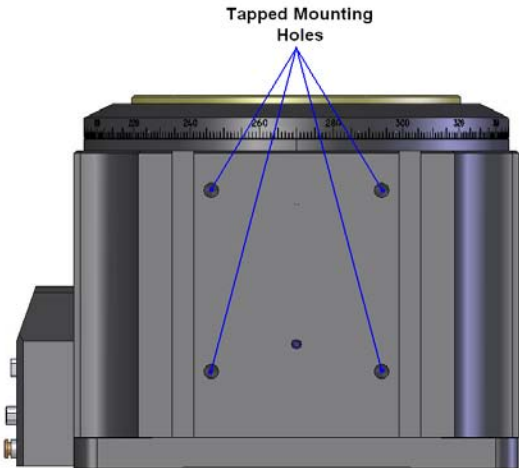

Figure 2-3: Side View of an ABRT-200 Stage Showing Tapped Mounting Holes

2.4. Attaching the Payload to the Stage

To prevent damage to the stage or parts, test the operation of the stage before any payload is mounted to the stage tabletop. Proceed with the electrical installation and test the motion control system in accordance with the system documentation. Document all results for future reference. For information on electrical connections, refer to the Electrical Installation section later in this chapter, the documentation of the motion control system delivered with the stage, and the wiring drawings in Chapter 3: Operating Specifications.

The payload must be flat, rigid and comparable to the stage in quality. *For valid accuracy, the mounting interface should be flat within 2 μ m TIR.* Additionally, the payload must be reasonably balanced in order to maintain stage accuracy. Please consult the factory to determine if the payload may potentially result in any deterioration of stage performance.

There are several mounting holes provided on the stage tabletop to mount payloads. The payload mounting holes are M5x0.8 or M6x1.0 (depending on the particular stage model) and have reinforced threads to allow frequent removal and installation of mounting screws.

2.5. Electrical Installation

Aerotech motion control systems are adjusted at the factory for optimum performance. When the ABRT series stage is part of a complete Aerotech motion control system, setup involves connecting a stage and motor combination to the appropriate drive chassis with the cables provided. Connect the provided cable to the feedback and motor connectors on the stage. Labels on the drive indicate the appropriate connections. Refer to your drive system manuals and documentation for additional installation and operation information. In some cases, if the system is uniquely configured, a drawing showing system interconnects is supplied.

Refer to Section 3.5. for standard motor wiring and connector pin outputs.



WARNING

Never connect or disconnect any electrical component or connecting cable while power is applied, or serious damage may result.



WARNING

The stage's protective ground is located on pin A4 of the motor connector. If you are using cables other than those provided by Aerotech, you must connect pin A4 to a ground connection.

2.6. Air Requirements

The air supply to the air bearing is important for the operation of the system. If compressed air is used, it must be filtered to 0.25 microns, dry to 0°F dew point, and oil free. If nitrogen is used, it must be 99.99% pure and filtered to 0.25 microns. The filtration requirement is to prevent particles from clogging the air bearing orifices, which can be as small as a few thousandths of an inch in diameter.

Air pressure of 80 psi, ± 5 psi, is necessary for use. Air should be supplied via 4 mm OD or 5/32" OD polyurethane air hose. It is recommended that a pressure switch be installed to remove power from the air bearing if pressure drops below 40 psi because the bearing surfaces could be damaged. An air flow rate of less than 2 SCFM should be observed (single axis).

Chapter 3: Operating Specifications

This chapter contains general technical information about ABRT series stages. Included are basic product specifications, resolution information, and motor wiring diagrams.

3.1. Environmental Specifications

The environmental specifications for the ABRT are listed in the following table.

Table 3-1: Environmental Specifications

Ambient Temperature	Operating: 16° to 25° C (61° to 77° F) The optimal operating temperature is 20° C \pm 2° C (68° F \pm 4° F). If at any time the operating temperature deviates from 20° C degradation in performance could occur. Contact Aerotech for information regarding your specific application and environment.
	Storage: 0° to 40° C (32° to 104° F) in original shipping packaging
Humidity	Operating: 40 percent to 60 percent RH The optimal operating humidity is 50 percent RH.
	Storage: 30 percent to 60 percent RH, non-condensing in original packaging
Altitude	Operating: 0 to 2,000 m (0 to 6,562 ft) above sea level Contact Aerotech if your specific application involves use above 2,000 m or below sea level.
Vibration	Use the system in a low vibration environment. Excessive floor or acoustical vibration can affect stage and system performance. Contact Aerotech for information regarding your specific application.
Dust Exposure	The ABRT stages are not suited for dusty or wet environments. This equates to an ingress protection rating of IP00.
Use	Indoor use only



Do not expose the stage to environments or conditions outside the specified range of operating environments. Operation in conditions other than those specified can cause damage to the equipment.

3.2. Basic Specifications

The ABRT series rotary stage specifications are shown in Table 3-2. Encoder resolution information is given in Table 3-3 and speed limitations are given in Table 3-4. Motor specifications are given in Table 3-5.

Table 3-2: ABRT Series Specifications

ABRT Series	ABRT-150	ABRT-200	ABRT-260
Width	146 mm	196 mm	260 mm
Tabletop Diameter	100 mm	145 mm	200 mm
Height	135 mm	165 mm	185 mm
Aperture	20 mm	30 mm	50 mm
Total Travel	±360° Continuous		
Motor	Direct-Drive Brushless Servomotor		
Stall Torque, Continuous	0.36 N-m	3.7 N-m	6.7 N-m
Peak Torque	1.4 N-m	14.6 N-m	26.6 N-m
BEMF, Line-Line, Max	10.9 V _{pk} /krpm	163.6 V _{pk} /krpm	129.8 V _{pk} /krpm
Continuous Current, Stall	3.8 A _{pk}	2.7 A _{pk}	6.2 A _{pk}
	2.7 A _{rms}	1.9 A _{rms}	4.4 A _{rms}
Torque Constant	0.09 N-m/A _{pk}	1.35 N-m/A _{pk}	1.07 N-m/A _{pk}
	0.13 N-m/A _{rms}	1.91 N-m/A _{rms}	1.52 N-m/A _{rms}
Resolution ⁽¹⁾	0.267 μrad (0.055 arc sec)	0.174 μrad (0.036 arc sec)	0.133 μrad (0.027 arc sec)
Max Speed ⁽²⁾	1200 rpm	800 rpm	600 rpm
Accuracy (calibrated)	±2 arc sec		
Repeatability	<1 arc sec		
Axial Error (synchronous)	<100 nm		
Radial Error (synchronous)	<150 nm		
Tilt Error (synchronous)	<0.5 arc sec		
Axial Error (asynchronous)	<20 nm		
Radial Error (asynchronous)	<20 nm		
Tilt Error (asynchronous)	<0.04 arc sec		
Inertia (unloaded)	2300 kg-mm ²	13,500 kg-mm ²	46,400 kg-mm ²
Total Mass	6.7 kg	14.7 kg	27.1 kg
Material	Aluminum		
Finish	Hard Coating (62 Rockwell Hardness)		
1. Maximum resolution presumes A3200 controller using MXH500 multiplication, and accounts for controller quadrature.			
2. Maximum speed based on stage capability. Maximum application velocity may be limited by system data rate and system resolution.			

Table 3-3: ABRT Series Resolution Information

	ABRT-150	ABRT-200	ABRT-260
Lines	11,840	18,000	23,600
X50	0.55 arc sec	0.36 arc sec	0.27 arc sec
AS (sine)*	109 arc sec	72 arc sec	55 arc sec
* Fundamental resolution of sine wave output from encoder. Up to x500 available with Aerotech controller.			

Table 3-4: ABRT Series Maximum Encoder Frequency

Resolution-Speed	ABRT-150	ABRT-200	ABRT-260
AS	1200 rpm	800 rpm	600 rpm
X50	636 rpm	415 rpm	318 rpm

NONE: The encoders used on all ABRS-series stages come standard with a 40 MHz clock rate. Aerotech can provide slower or faster clock rates to match the controller being used. Consult the factory for more information.

Table 3-5: ABRT Series Motor Specifications

Stage		ABRT-150	ABRT-200	ABRT-260
Performance Specifications (1,5)				
Stall Torque, Continuous (2)	N-m	0.34	3.65	6.65
	in-lb	3.0	32.3	58.9
Peak Torque (3)	N-m	1.37	14.60	26.60
	in-lb	12.1	129.2	235.5
Rated Speed	rpm	2,000	500	600
Rated Power Output, Continuous	watts	71.6	191.1	417.8
Electrical Specifications (5)				
BEMF Constant (line to line, max)	Volts pk/krpm	10.9	163.6	129.8
Continuous Current, Stall (2)	Amp pk	3.8	2.7	6.2
	Amp rms	2.7	1.9	4.4
Peak Current, Stall (3)	Amp pk	15.2	10.8	24.8
	Amp rms	10.7	7.6	17.5
Torque Constant (4,9)	N-m / Amp pk	0.09	1.35	1.07
	in-lb / Amp pk	0.8	12.0	9.5
	N-m / Amp rms	0.13	1.91	1.52
	in-lb / Amp rms	1.1	16.9	13.4
Motor Constant (2,4)	N-m / \sqrt{W}	0.039	0.383	0.524
	in-lb / \sqrt{W}	0.34	3.39	4.64
Resistance, 25 °C (line to line)	ohms	5.6	12.8	4.3
Inductance (line to line)	mH	1.70	3.40	2.15
Maximum Bus Voltage	VDC	340	340	340
Thermal Resistance	°C / W	0.95	0.82	0.47
Number of Poles	P	18	18	26
(1) Performance is dependent upon heat sink configuration, system cooling conditions, and ambient temperature (2) Values shown @ 75 °C rise above a 25 °C ambient temperature, with housed motor mounted to a 330 mm x 330 mm x 13 mm aluminum heat sink (3) Peak torque assumes correct rms current, consult Aerotech (4) Torque Constant and Motor Constant specified at stall (5) All performance and electrical specifications +/- 10% (6) Losses due to bearings and aerodynamics considered negligible (7) Maximum winding temperature is 100 °C, Thermistor trips at 100 °C (8) Ambient operating temperature range: 0 °C - 25 °C, consult Aerotech for performance in elevated ambient temperatures (9) All Aerotech amplifiers are rated Apk; use torque constant in N-m / Apk when sizing				

3.3. Load Capability

The ABRT rotary stage loading specifications are shown in Table 3-6.

Table 3-6: ABRT Series Load Capability

ABRT Series	ABRT-150	ABRT-200	ABRT-260
Max Load – Axial*	20 kg	40 kg	70 kg
Max Load – Radial*	4 kg	10 kg	18 kg
Max Load – Tilt*	3.5 N-m	10 N-m	20 N-m
* Maximum loads are mutually exclusive.			

3.4. Limit Switch Wiring

Standard ABRT stages do not include end-of-travel limits. Please consult the factory for a custom solution.

3.5. Standard Motor Wiring

Stages come from the factory completely wired and assembled. For reference, connector pin outputs (pin-outs) and general wiring information are given in the following figures. Pinouts are defined in Table 3-9.

Every ABRT stage is supplied with a special feedback cable that includes the optical encoder electronic interface box. This interface box is required for processing the encoder signals and is necessary for both the sine wave output and the square wave digital output versions. Connector pinouts and general wiring information for this special ABRT feedback cable are given in Table 3-8.

NOTE: Refer to the other documentation accompanying your Aerotech equipment. Call your Aerotech representative if there are any questions on system configuration.

NOTE: If you are using your own cables to connect the stage, ensure that the motor and ground wires can handle current higher than the continuous current listed in Table 3-5. The voltage rating of the wire insulation must be greater than the maximum bus voltage listed in Table 3-5.

Table 3-7: Standard Wiring Connectors for ABRT-200MP, -250MP, and -300MP Stages

			
Pin	Description	Pin	Description
A1	MTR ØA	3	RESERVED
A2	MTR ØB	4	RESERVED
A3	MTR ØC	5	RESERVED
1	MTR SHLD	A4	FRM GND
2	RESERVED		
			
Pin	Description	Pin	Description
1	SIG SHLD	14	COS
2	TH+	15	COS-N
3	ENC +5V	16	LMT +5V
4		17	SIN
5	HALL B	18	SIN-N
6	MKR-N	19	
7	MKR	20	LMT COM & TH-
8	RESERVED	21	ENC COM
9	SERVO	22	RED-GREEN
10	HALL A	23	
11	HALL C	24	Q LIMIT
12	P LIMIT	25	
13			

Table 3-8: Special Feedback Cable with Encoder Interface Box



Pinout of "To Controller" Connector

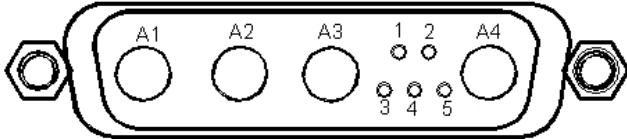
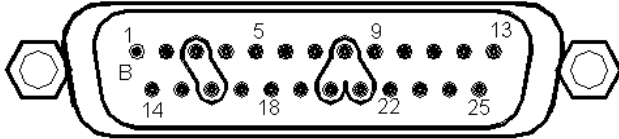
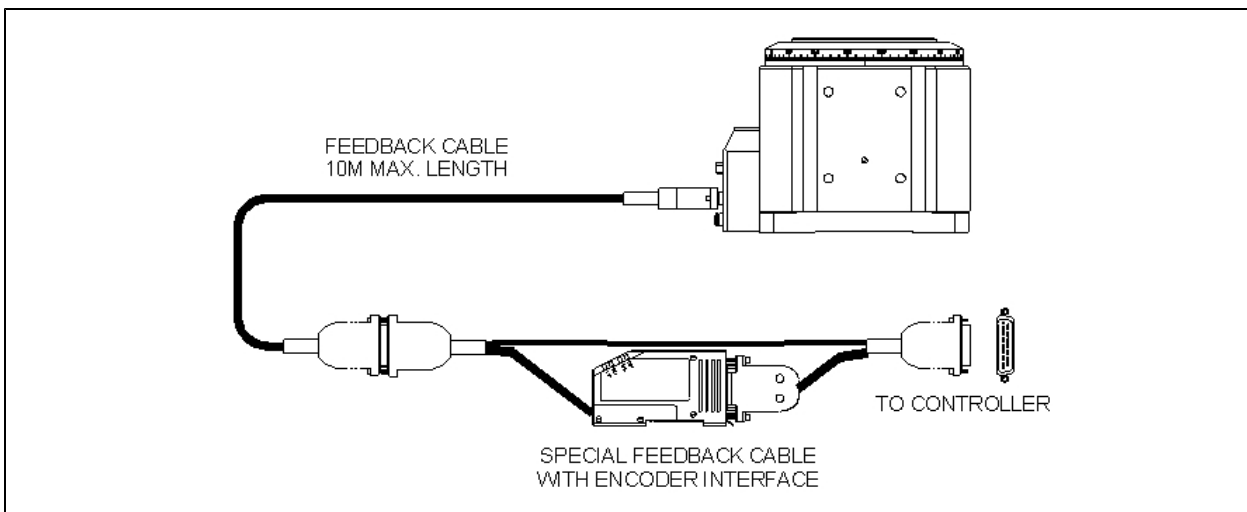
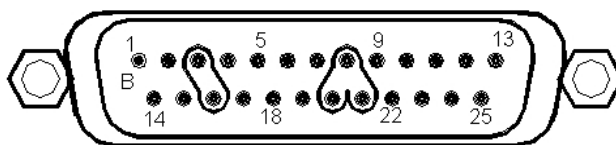

Pin	Description	Pin	Description
1	SIG SHLD	14	COS
2	TH+	15	COS-N
3	ENC +5V	16	LMT +5V
4		17	SIN
5	HALL B	18	SIN-N
6	MKR-N	19	
7	MKR	20	LMT COM & TH-
8		21	ENC COM
9	SETUP	22	
10	HALL A	23	ENC FLT
11	HALL C	24	
12		25	
13			

Table 3-9: Motor Wiring Pinout Descriptions

Pin Output	Description
COS	Cosine. Incremental encoder output; either TTL line driven or amplified sine wave type signal.
COS-N	Incremental encoder output. Complement of cos.
ENC COM	+ 5 V return for optical encoders (ground).
ENC +5V	+5 V supply input for optical encoders. Typical requirement is 250 mA.
HALL A	Hall Effect A. Brushless motor commutation track output. TTL line driven signal with rotary motor.
HALL B	Hall Effect B. Brushless motor commutation track output. TTL line driven signal with rotary motor.
HALL C	Hall Effect C. Brushless motor commutation track output. TTL line driven signal with rotary motor.
INNER SHLD	Shield for optical encoder cable
LMT +5v	+ 5 V supply input for optical limit switch boards. Typical requirement is 50 mA.
LMT COM	Common ground for limit switch
MKR	Marker. Incremental encoder output pulse given once per revolution. Typically used for home reference cycle.
MKR-N	Incremental encoder output; either the compliment of Marker with a line driven, TTL type encoder or 2.5 V DC bias level with amplified sine wave type encoder.
SIN	Sine. Incremental encoder output; either TTL line driven or amplified sign wave type signal.
SIN-N	Incremental encoder output. Complement of sin.
TH+	Positive lead for motor thermistor (to motion controller)
TH-	Negative lead for motor thermistor (tied to ground via feedback connector).
MTR ØA	Motor Phase A.
MTR ØB	Motor Phase B.
MTR ØC	Motor Phase C.
FRM GND	Ground to stage base
P LIMIT	Optical encoder "P" limit output
Q LIMIT	Optical encoder "Q" limit output
RED-GREEN	
SERVO	Monitors the IRED voltage of the optical encoder
SIG SHLD	Shield for feedback connector
MTR SHLD	Shield for motor wiring connector

3.6. Vacuum Operation

The ABRT is an air-bearing stage and is not compatible with operation in a vacuum environment. Please contact the factory for alternate solutions.

Chapter 4: Maintenance

The ABRT series stages are designed to be maintenance-free positioning systems. Due to the non-contact air bearing design, there are no friction surfaces or dynamic seals to wear or require lubrication. The ABRT stages do not require any maintenance other than periodic cleaning. Included in this chapter are recommended cleaning solvents.

NOTE: The stage must be kept free of foreign matter and moisture; otherwise, the performance and life expectancy of the stage will be reduced.



To minimize the possibility of bodily injury, confirm that all electrical power is disconnected prior to making any mechanical adjustments.

4.1. Service and Inspection Schedule

It is recommended that the ABRT stage be inspected once per month until a trend develops for the specific application and environment.

4.1.1. Field Service

In general, repair and/or replacement of damaged or malfunctioning components of the ABRT stage by Aerotech field service personnel is not possible. Stage repair typically requires that the unit be returned to the factory. Please contact Aerotech Technical Support for more information.

4.2. Cleaning and Lubrication

There are no elements of the ABRT series stages that require lubrication. Periodic cleaning to remove dust is recommended.

4.2.1. Recommended Cleaning Solvents

Before using a cleaning solvent on any part of the stage, it is recommended that compressed nitrogen or clean, dry air be used to blow away small particles and dust. Any metal surface of the stage may be cleaned with isopropyl alcohol on a lint-free cloth. Avoid getting excess cleaning solvent on the surfaces, as it could damage the delicate electronics inside.



To minimize the possibility of bodily injury, confirm that all electrical power is disconnected prior to making any mechanical adjustments.

Appendix A: Warranty and Field Service

Aerotech, Inc. warrants its products to be free from defects caused by faulty materials or poor workmanship for a minimum period of one year from date of shipment from Aerotech. Aerotech's liability is limited to replacing, repairing or issuing credit, at its option, for any products that are returned by the original purchaser during the warranty period. Aerotech makes no warranty that its products are fit for the use or purpose to which they may be put by the buyer, where or not such use or purpose has been disclosed to Aerotech in specifications or drawings previously or subsequently provided, or whether or not Aerotech's products are specifically designed and/or manufactured for buyer's use or purpose. Aerotech's liability or any claim for loss or damage arising out of the sale, resale or use of any of its products shall in no event exceed the selling price of the unit.

Aerotech, Inc. warrants its laser products to the original purchaser for a minimum period of one year from date of shipment. This warranty covers defects in workmanship and material and is voided for all laser power supplies, plasma tubes and laser systems subject to electrical or physical abuse, tampering (such as opening the housing or removal of the serial tag) or improper operation as determined by Aerotech. This warranty is also voided for failure to comply with Aerotech's return procedures.

Laser Products

Claims for shipment damage (evident or concealed) must be filed with the carrier by the buyer. Aerotech must be notified within (30) days of shipment of incorrect materials. No product may be returned, whether in warranty or out of warranty, without first obtaining approval from Aerotech. No credit will be given nor repairs made for products returned without such approval. Any returned product(s) must be accompanied by a return authorization number. The return authorization number may be obtained by calling an Aerotech service center. Products must be returned, prepaid, to an Aerotech service center (no C.O.D. or Collect Freight accepted). The status of any product returned later than (30) days after the issuance of a return authorization number will be subject to review.

Return Procedure

After Aerotech's examination, warranty or out-of-warranty status will be determined. If upon Aerotech's examination a warranted defect exists, then the product(s) will be repaired at no charge and shipped, prepaid, back to the buyer. If the buyer desires an airfreight return, the product(s) will be shipped collect. Warranty repairs do not extend the original warranty period.

Returned Product Warranty Determination

After Aerotech's examination, the buyer shall be notified of the repair cost. At such time, the buyer must issue a valid purchase order to cover the cost of the repair and freight, or authorize the product(s) to be shipped back as is, at the buyer's expense. Failure to obtain a purchase order number or approval within (30) days of notification will result in the product(s) being returned as is, at the buyer's expense. Repair work is warranted for (90) days from date of shipment. Replacement components are warranted for one year from date of shipment.

Returned Product Non-warranty Determination

At times, the buyer may desire to expedite a repair. Regardless of warranty or out-of-warranty status, the buyer must issue a valid purchase order to cover the added rush service cost. Rush service is subject to Aerotech's approval.

Rush Service

On-site Warranty Repair If an Aerotech product cannot be made functional by telephone assistance or by sending and having the customer install replacement parts, and cannot be returned to the Aerotech service center for repair, and if Aerotech determines the problem could be warranty-related, then the following policy applies:

Aerotech will provide an on-site field service representative in a reasonable amount of time, provided that the customer issues a valid purchase order to Aerotech covering all transportation and subsistence costs. For warranty field repairs, the customer will not be charged for the cost of labor and material. If service is rendered at times other than normal work periods, then special service rates apply.

If during the on-site repair it is determined the problem is not warranty related, then the terms and conditions stated in the following "On-Site Non-Warranty Repair" section apply.

On-site Non-warranty Repair If any Aerotech product cannot be made functional by telephone assistance or purchased replacement parts, and cannot be returned to the Aerotech service center for repair, then the following field service policy applies:

Aerotech will provide an on-site field service representative in a reasonable amount of time, provided that the customer issues a valid purchase order to Aerotech covering all transportation and subsistence costs and the prevailing labor cost, including travel time, necessary to complete the repair.

Company Address Aerotech, Inc.
101 Zeta Drive
Pittsburgh, PA
15238-2897

Phone: (412) 963-7470

Fax: (412) 963-7459

Appendix B: Technical Changes

Table B-1: Current Changes (1.04.00)

Section(s) Affected	General Information
Section 1.4.	Added section
Section 3.1.	Added section
Chapter 2: Installation, Section 2.1. , Section 2.3. , Section 2.5. , and Sec- tion 1.3.	Added safety information and warnings
Section 1.1.2.	Corrected peak output torque values
Section 3.2.	Added motor specifications
Section 3.5.	Added note about current requirements of motor and ground wires, changed pin 8 to reserved

Table B-2: Archived Changes

Revision	Section(s) Affected	General Information
1.03.00	Table 3-2	Unloaded inertia is now 2300 kg/mm ² (was 2700)
1.02.00	Section 1.2.	Dimensions section added
1.01.00	Table 3-2	Specifications for the ABRT-150 updated (Stall Torque, Peak Torque, BEMF, and Torque Constant).
1.00.00	--	New Manual

Index

A		U	
air requirements.....	15	Unpacking and Handling the Stage.....	9
Attaching the Payload.....	13	W	
C		Warnings.....	6
Cleaning.....	25		
D			
Declaration of Incorporation.....	8		
Dimensions.....	3		
E			
Electrical Installation.....	14		
Environmental Specifications.....	17		
L			
limit switches.....	21		
Lubrication.....	25		
lubrication schedule.....	25		
M			
model numbers.....	9		
O			
Optional Features.....	1		
P			
Preparing the Mounting Surface.....	10		
S			
safety procedures.....	6		
Securing the Stage to the Mounting Surface.....	11		
Specifications.....	18		
Standard Features.....	1		

