

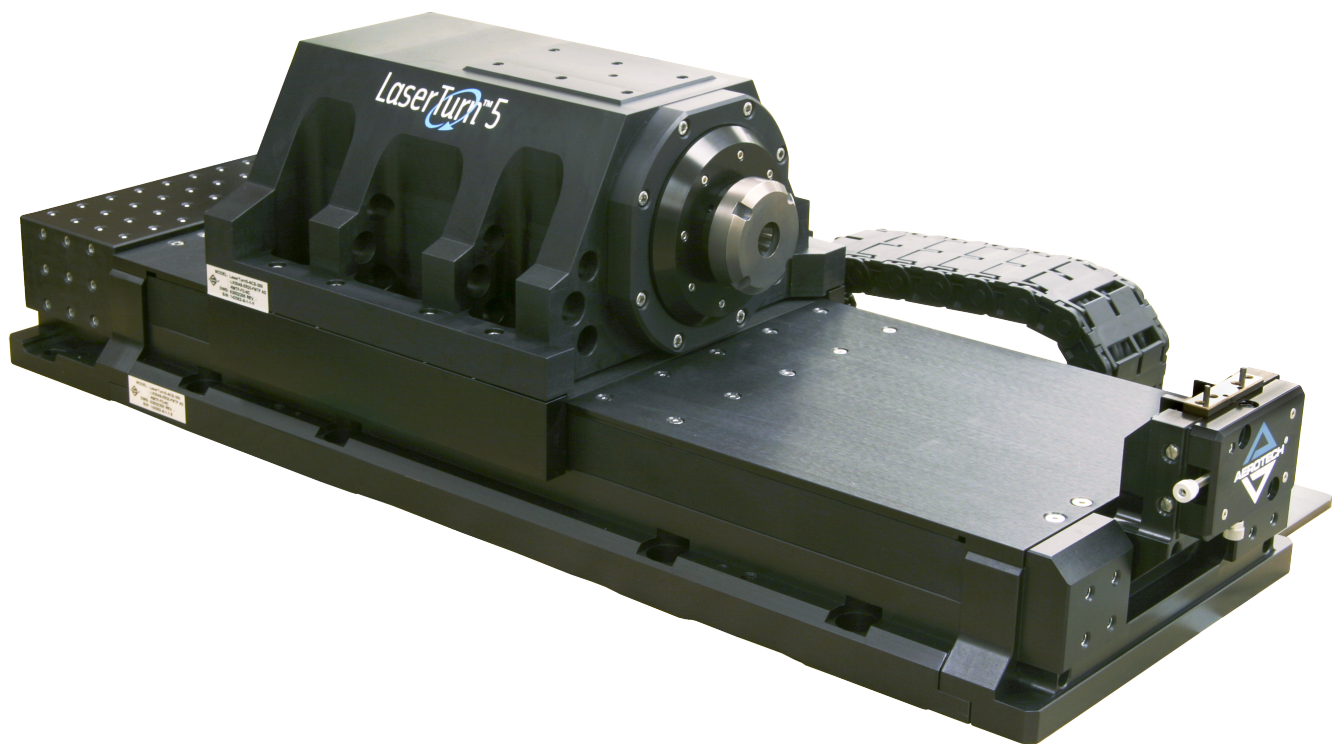

# LaserTurn<sup>®</sup> 5-ASR Hardware Manual

Revision: 1.04.00



## Global Technical Support

Go to [www.aerotech.com/global-technical-support](http://www.aerotech.com/global-technical-support) for information and support about your Aerotech products. The website provides downloadable resources (such as up-to-date software, product manuals, and Help files), training schedules, and PC-to-PC remote technical support. You can also complete Product Return (RMA) forms and get information about repairs and spare or replacement parts. For immediate help, contact a service office or your sales representative. Have your customer order number available before you call or include it in your email.

| United States (World Headquarters)                                                                                                     |                                                                                                                                        |
|----------------------------------------------------------------------------------------------------------------------------------------|----------------------------------------------------------------------------------------------------------------------------------------|
| Phone: +1-412-967-6440<br>Fax: +1-412-967-6870<br>Email: <a href="mailto:service@aerotech.com">service@aerotech.com</a>                | 101 Zeta Drive<br>Pittsburgh, PA 15238-2811<br><a href="http://www.aerotech.com">www.aerotech.com</a>                                  |
| United Kingdom                                                                                                                         | Japan                                                                                                                                  |
| Phone: +44 (0)1256 855055<br>Fax: +44 (0)1256 855649<br>Email: <a href="mailto:service@aerotech.co.uk">service@aerotech.co.uk</a>      | Phone: +81 (0)50 5830 6814<br>Fax: +81 (0)43 306 3773<br>Email: <a href="mailto:service@aerotechkk.co.jp">service@aerotechkk.co.jp</a> |
| Germany                                                                                                                                | China                                                                                                                                  |
| Phone: +49 (0)911 967 9370<br>Fax: +49 (0)911 967 93720<br>Email: <a href="mailto:service@aerotechgmbh.de">service@aerotechgmbh.de</a> | Phone: +86 (21) 5508 6731<br>Email: <a href="mailto:service@aerotech.com">service@aerotech.com</a>                                     |
| France                                                                                                                                 | Taiwan                                                                                                                                 |
| Phone: +33 2 37 21 87 65<br>Email: <a href="mailto:service@aerotech.co.uk">service@aerotech.co.uk</a>                                  | Phone: +886 (0)2 8751 6690<br>Email: <a href="mailto:service@aerotech.tw">service@aerotech.tw</a>                                      |

This manual contains proprietary information and may not be reproduced, disclosed, or used in whole or in part without the express written permission of Aerotech, Inc. Product names mentioned herein are used for identification purposes only and may be trademarks of their respective companies.

Copyright © 2014-2018, Aerotech, Inc., All rights reserved.

## Aerotech Worldwide

United States ■ France ■ Germany ■ United Kingdom  
China ■ Japan ■ Taiwan



## Table of Contents

|                                                                    |           |
|--------------------------------------------------------------------|-----------|
| <b>LaserTurn®5-ASR Hardware Manual</b> .....                       | <b>1</b>  |
| Table of Contents .....                                            | 3         |
| List of Figures .....                                              | 4         |
| List of Tables .....                                               | 5         |
| Safety Procedures and Warnings .....                               | 6         |
| EU Declaration of Incorporation .....                              | 7         |
| <b>Chapter 1: Overview</b> .....                                   | <b>9</b>  |
| 1.1. Environmental Specifications .....                            | 10        |
| 1.2. Accuracy and Temperature Effects .....                        | 10        |
| 1.3. Basic Specifications .....                                    | 11        |
| <b>Chapter 2: Installation</b> .....                               | <b>13</b> |
| 2.1. Unpacking and Handling the Stage .....                        | 13        |
| 2.2. Dimensions .....                                              | 15        |
| 2.3. Securing the Stage to the Mounting Surface .....              | 17        |
| 2.4. Air Requirements .....                                        | 19        |
| 2.5. Wet Cut Fluid Requirements .....                              | 19        |
| 2.6. Attaching the Payload to the Stage .....                      | 20        |
| 2.7. Load Capability .....                                         | 21        |
| 2.8. Changing the Workholding Devices .....                        | 22        |
| 2.8.1. Collet Installation and Removal Procedure .....             | 22        |
| 2.9. Gripper Installation (-FT2) .....                             | 25        |
| 2.10. Alignment Gripper Installation (-FT3 and -FT6) .....         | 26        |
| 2.11. Gripper Jaw Interface .....                                  | 28        |
| <b>Chapter 3: Electrical Specifications and Installation</b> ..... | <b>29</b> |
| 3.1. Motor and Feedback Connectors .....                           | 30        |
| 3.2. Motor and Feedback Wiring .....                               | 34        |
| 3.3. Motor and Feedback Specifications .....                       | 36        |
| 3.4. Limits, Marker, and Machine Direction .....                   | 40        |
| 3.5. Motor and Feedback Phasing .....                              | 41        |
| <b>Chapter 4: Maintenance</b> .....                                | <b>43</b> |
| 4.1. Service and Inspection Schedule .....                         | 43        |
| 4.2. Cleaning and Lubrication .....                                | 44        |
| 4.2.1. Collet & Collet Chuck Lubrication and Cleaning .....        | 45        |
| 4.2.2. Linear Lubrication and Cleaning Process .....               | 46        |
| 4.3. Seal Replacement .....                                        | 47        |
| 4.3.1. Piston Seal Change Procedure .....                          | 47        |
| 4.3.2. Ringseal O-Ring Replacement .....                           | 47        |
| 4.3.3. Wet Cut Rotary Union Seal Replacement .....                 | 49        |
| 4.4. Wet Cut Rotary Union Removal .....                            | 53        |
| 4.5. Linear Hardcover Removal .....                                | 55        |
| 4.6. Troubleshooting .....                                         | 56        |
| <b>Appendix A: Warranty and Field Service</b> .....                | <b>57</b> |
| <b>Appendix B: Revision History</b> .....                          | <b>59</b> |
| <b>Index</b> .....                                                 | <b>61</b> |

**List of Figures**

Figure 2-1: LaserTurn®5-ASR Shipping Clamps ..... 14

Figure 2-2: LaserTurn®5-ASR Lifting Points ..... 14

Figure 2-3: LaserTurn®5-ASR Dimensions (part one) ..... 15

Figure 2-4: LaserTurn®5-ASR Dimensions (part two) ..... 16

Figure 2-5: LaserTurn®5-ASR Stage Showing Mounting Holes (Top View) ..... 18

Figure 2-6: Tooling Platform Hardware ..... 18

Figure 2-7: LaserTurn®5-ASR Wet Cut Rotary Union Location ..... 21

Figure 2-8: Inserting the Collet into the Collet Nut ..... 23

Figure 2-9: Installing the Collet and Collet Nut ..... 24

Figure 2-10: Gripper Detail ..... 25

Figure 2-11: Alignment Gripper ..... 27

Figure 2-12: Gripper Jaw Interface Dimensions ..... 28

Figure 3-1: Motor and Feedback Wiring (Rotary Axis) ..... 34

Figure 3-2: Motor and Feedback Wiring (Linear Axis) ..... 35

Figure 3-3: Machine Direction ..... 40

Figure 3-4: Hall Phasing ..... 41

Figure 3-5: Analog Encoder Phasing Reference Diagram ..... 42

Figure 4-1: Linear Bearing Grease Nipple ..... 46

Figure 4-2: Ringseal Removal and Replacement ..... 47

Figure 4-3: Typical Ringseal ..... 48

Figure 4-4: Cross-Section View of Ringseal Showing O-Ring ..... 48

Figure 4-5: Cross-Section View of Wet Cut Rotary Union ..... 49

Figure 4-6: Carriage Cover Removal ..... 50

Figure 4-7: Seal Assembly Removal ..... 50

Figure 4-8: Wet Cut Rotary Union Shaft Inspection ..... 52

Figure 4-9: Wet Cut Rotary Union ..... 53

Figure 4-10: Wet Cut Rotary Union Removal ..... 54

Figure 4-11: Linear Hardcover Removal ..... 55

## List of Tables

|                                                                                 |    |
|---------------------------------------------------------------------------------|----|
| Table 1-1: Model Numbering System .....                                         | 9  |
| Table 1-2: Environmental Specifications .....                                   | 10 |
| Table 1-3: LaserTurn®5-ASR Series Specifications .....                          | 11 |
| Table 3-1: 4-Pin HPD Motor Connector Pinouts (for Rotary and Linear Axes) ..... | 31 |
| Table 3-2: 4-Pin D Motor Mating Connector .....                                 | 31 |
| Table 3-3: 25-Pin D Feedback Connector Pinouts (Rotary Axis) .....              | 32 |
| Table 3-4: 25-Pin D Feedback Mating Connector .....                             | 32 |
| Table 3-5: 25-Pin Feedback Connector Pinouts (Linear Axis) .....                | 33 |
| Table 3-6: 25-Pin D Feedback Mating Connector .....                             | 33 |
| Table 3-7: Feedback Specifications .....                                        | 36 |
| Table 3-8: Rotary Axis Motor Specifications (BM250) .....                       | 37 |
| Table 3-9: Rotary Axis Motor Specifications, -WCUT (BM250) .....                | 38 |
| Table 3-10: Linear Axis Motor Specifications (BLM-264-A) .....                  | 39 |
| Table 4-1: Recommended Lubricants .....                                         | 45 |

## Safety Procedures and Warnings

Read this manual in its entirety before installing, operating, or servicing this product. If you do not understand the information contained herein, contact an Aerotech representative before proceeding. Strictly adhere to the statements given in this section and other handling, use, and operational information given throughout the manual to avoid injury to you and damage to the equipment.

The following statements apply wherever the Warning or Danger symbol appears within this manual. Failure to observe these precautions could result in serious injury to those individuals performing the procedures and/or damage to the equipment.



**DANGER:** This product contains potentially lethal voltages. To reduce the possibility of electrical shock, bodily injury, or death the following precautions must be followed.

1. Access to the LaserTurn®5-ASR and component parts must be restricted while connected to a power source.
2. Do not connect or disconnect any electrical components or connecting cables while connected to a power source.
3. Disconnect electrical power before servicing equipment.
4. All components must be properly grounded in accordance with local electrical safety requirements.
5. Operator safeguarding requirements must be addressed during final integration of the product.



**WARNING:** To minimize the possibility of electrical shock, bodily injury or death the following precautions must be followed.

1. Moving parts can cause crushing or shearing injuries. Access to all stage and motor parts must be restricted while connected to a power source.
2. Cables can pose a tripping hazard. Securely mount and position all system cables to avoid potential hazards.
3. Do not expose this product to environments or conditions outside of the listed specifications. Exceeding environmental or operating specifications can cause damage to the equipment.
4. The LaserTurn®5-ASR stage must be mounted securely. Improper mounting can result in injury and damage to the equipment.
5. Use care when moving the LaserTurn®5-ASR stage. Lifting or transporting the LaserTurn®5-ASR stage improperly can result in injury or damage to the LaserTurn®5-ASR.
6. This product is intended for light industrial manufacturing or laboratory use. Use of this product for unintended applications can result in injury and damage to the equipment.
7. If the product is used in a manner not specified by the manufacturer, the protection provided by the product can be impaired and result in damage, shock, injury, or death.
8. Operators must be trained before operating this equipment.
9. All service and maintenance must be performed by qualified personnel.

## EU Declaration of Incorporation

**Manufacturer:** Aerotech, Inc.  
101 Zeta Drive  
Pittsburgh, PA 15238-2811  
USA

**herewith declares that the product:**  
LaserTurn®5-ASR Stage

**is intended to be incorporated into machinery to constitute machinery covered by the Directive 2006/42/EC as amended;**

**and that the following harmonized European standards have been applied:**

EN ISO 12100:2010

Safety of machinery - Basic concepts, general principles for design

EN 60204-1:2010

Safety of machinery - Electrical equipment of machines - Part 1: General requirements

**and further more declares that**

***it is not allowed to put the equipment into service until the machinery into which it is to be incorporated or of which it is to be a component has been found and declared to be in conformity with the provisions of the Directive 2006/42/EC and with national implementing legislation, i.e., as a whole, including the equipment referred to in this Declaration.***

*This is to certify that the aforementioned product is in accordance with the applicable requirements of the following Directive(s):*

2011/65/EU

RoHS 2 Directive

**Authorized Representative:** Simon Smith, European Director  
**Address:** Aerotech Ltd  
The Old Brick Kiln, Ramsdell, Tadley  
Hampshire RG26 5PR  
UK

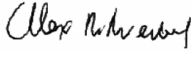
**Name**  / Alex Weibel  
**Position** Engineer Verifying Compliance  
**Location** Pittsburgh, PA  
**Date** 6/22/2018



*This page intentionally left blank.*



## Chapter 1: Overview

**NOTE:** Aerotech continually improves its product offerings; listed options may be superseded at any time. All drawings and illustrations are for reference only and were complete and accurate as of this manual's release. Refer to [www.aerotech.com](http://www.aerotech.com) for the most up-to-date information.

**Table 1-1: Model Numbering System**

| <b>LaserTurn®5-ASR Linear / Rotary Platform</b>            |                                                                                    |
|------------------------------------------------------------|------------------------------------------------------------------------------------|
| <b>Travel (Required)</b>                                   |                                                                                    |
| -200                                                       | 200 mm linear axis travel                                                          |
| -300                                                       | 300 mm linear axis travel                                                          |
| <b>Feedback (Required)</b>                                 |                                                                                    |
| -E1                                                        | Incremental linear encoder, 1 Vpp (linear axis)                                    |
| -E2                                                        | High-accuracy incremental linear encoder, 1 Vpp (linear axis)                      |
| <b>Rotary Speed (Required)</b>                             |                                                                                    |
| -SS                                                        | Standard speed rotary axis                                                         |
| -HS                                                        | High speed rotary axis                                                             |
| <b>Cutting Configuration (Required)</b>                    |                                                                                    |
| -DCUT                                                      | Dry cutting configuration                                                          |
| -WCUT                                                      | Wet cutting configuration with fluid rotary union                                  |
| <b>Front Tooling (Optional)</b>                            |                                                                                    |
| -FT1                                                       | Metric front tooling platform                                                      |
| -FT2                                                       | Metric front tooling platform with gripper                                         |
| -FT3                                                       | Metric front tooling platform with alignment gripper                               |
| -FT4                                                       | English front tooling platform                                                     |
| -FT5                                                       | English front tooling platform with gripper                                        |
| -FT6                                                       | English front tooling platform with alignment gripper                              |
| <b>Gripper Jaws (Optional)</b>                             |                                                                                    |
| -J1                                                        | Gripper jaws for 0-10 mm tube diameters                                            |
| <b>Rear Tooling (Optional)</b>                             |                                                                                    |
| -RT1                                                       | Metric rear tooling platform                                                       |
| -RT2                                                       | English rear tooling platform                                                      |
| <b>Metrology - Linear (Required)</b>                       |                                                                                    |
| -PL1                                                       | Metrology, uncalibrated with performance plots                                     |
| -PL2                                                       | Metrology, calibrated (HALAR) with performance plots                               |
| <b>Metrology - Rotary (Required)</b>                       |                                                                                    |
| -PL1                                                       | Metrology, uncalibrated with performance plots                                     |
| -PL2                                                       | Metrology, calibrated (HALAR) with performance plots                               |
| <b>Accessories (To be Ordered as a Separate Line Item)</b> |                                                                                    |
| Collet-ER16-CLTxxx                                         | ER16 collet (consult with Aerotech for available sizes)                            |
| RingSeal-ER16-RSxx                                         | Ring seal for wet cutting, ER16 collet (consult with Aerotech for available sizes) |
| CGF                                                        | Collet and gripper filtration kit                                                  |

## 1.1. Environmental Specifications



**WARNING:** Do not expose this product to environments or conditions outside of the listed specifications. Exceeding environmental or operating specifications can cause damage to the equipment.

**Table 1-2: Environmental Specifications**

|                            |                                                                                                                                                                                                                                                                                        |
|----------------------------|----------------------------------------------------------------------------------------------------------------------------------------------------------------------------------------------------------------------------------------------------------------------------------------|
| <b>Ambient Temperature</b> | Operating: 10° to 35° C (50° to 95° F)<br>The optimal operating temperature is 20° C ±2° C (68° F ±4° F). If at any time the operating temperature deviates from 20° C, degradation in performance could occur.<br>Storage: 0° to 40° C (32° to 104° F) in original shipping packaging |
| <b>Humidity</b>            | Operating: 40% to 60% RH<br>The optimal operating humidity is 50 percent RH.<br>Storage: 30% to 60% RH, non-condensing in original packaging. The stage should be packaged with desiccant if it is to be stored for an extended time.                                                  |
| <b>Altitude</b>            | Operating: 0 m to 2,000 m (0 ft to 6,562 ft) above sea level<br>Contact Aerotech if your specific application involves use above 2,000 m or below sea level.                                                                                                                           |
| <b>Vibration</b>           | Use the system in a low vibration environment. Excessive floor or acoustical vibration can affect system performance. Contact Aerotech for information regarding your specific application.                                                                                            |
| <b>Protection Rating</b>   | The LaserTurn®5-ASR stages have limited protection against dust, but not water. This equates to an ingress protection rating of IP50.                                                                                                                                                  |
| <b>Use</b>                 | Indoor use only                                                                                                                                                                                                                                                                        |

## 1.2. Accuracy and Temperature Effects

Extreme temperature changes could cause a decrease in performance or permanent damage to the stage. Aerotech stages are designed for and built in a 20°C (68°F) environment. Any deviation from standard operating temperature will affect stage accuracy. The severity of temperature effects on all stage specifications depends on many different environmental conditions, including how the stage is mounted. Contact the factory for more details.

The thermal expansion coefficient of the encoder scale is 8.0 ppm/°C. Travel will increase or decrease at this rate as the temperature of the encoder scale temperature deviates from 20°C (68°F).

### 1.3. Basic Specifications

**Table 1-3: LaserTurn®5-ASR Series Specifications**

|                                                                                                                                                                                                                                                                                                                                                                                                                                                                                                                                                                                                                                                                                                                                                                                                                                          |        | Linear Axis                                                    |                                           | Rotary Axis                                     |
|------------------------------------------------------------------------------------------------------------------------------------------------------------------------------------------------------------------------------------------------------------------------------------------------------------------------------------------------------------------------------------------------------------------------------------------------------------------------------------------------------------------------------------------------------------------------------------------------------------------------------------------------------------------------------------------------------------------------------------------------------------------------------------------------------------------------------------------|--------|----------------------------------------------------------------|-------------------------------------------|-------------------------------------------------|
| Travel                                                                                                                                                                                                                                                                                                                                                                                                                                                                                                                                                                                                                                                                                                                                                                                                                                   |        | 200 mm                                                         | 300 mm                                    | ±360° Continuous                                |
| Accuracy                                                                                                                                                                                                                                                                                                                                                                                                                                                                                                                                                                                                                                                                                                                                                                                                                                 | -E1    | Calibrated: ±1 µm<br>Uncalibrated: ±8 µm                       | Calibrated: ±1 µm<br>Uncalibrated: ±12 µm | ±73 µrad (±15 arc sec)                          |
|                                                                                                                                                                                                                                                                                                                                                                                                                                                                                                                                                                                                                                                                                                                                                                                                                                          | -E2    | Calibrated: ±1 µm<br>Uncalibrated: ±5 µm                       |                                           |                                                 |
| Bidirectional Repeatability                                                                                                                                                                                                                                                                                                                                                                                                                                                                                                                                                                                                                                                                                                                                                                                                              |        | ±0.5 µm                                                        |                                           | ±15 µrad (±3 arc sec)                           |
| Straightness                                                                                                                                                                                                                                                                                                                                                                                                                                                                                                                                                                                                                                                                                                                                                                                                                             |        | ±2 µm                                                          | ±3 µm                                     | N/A                                             |
| Flatness                                                                                                                                                                                                                                                                                                                                                                                                                                                                                                                                                                                                                                                                                                                                                                                                                                 |        | ±2 µm                                                          | ±3 µm                                     | N/A                                             |
| Pitch                                                                                                                                                                                                                                                                                                                                                                                                                                                                                                                                                                                                                                                                                                                                                                                                                                    |        | 39 µrad (8 arc sec)                                            | 49 µrad (10 arc sec)                      | N/A                                             |
| Yaw                                                                                                                                                                                                                                                                                                                                                                                                                                                                                                                                                                                                                                                                                                                                                                                                                                      |        | 39 µrad (8 arc sec)                                            | 49 µrad (10 arc sec)                      | N/A                                             |
| Maximum Speed <sup>(1)</sup>                                                                                                                                                                                                                                                                                                                                                                                                                                                                                                                                                                                                                                                                                                                                                                                                             |        | 2 m/s                                                          |                                           | 800 rpm<br>2000 rpm (-HS option)                |
| Tube Capacity                                                                                                                                                                                                                                                                                                                                                                                                                                                                                                                                                                                                                                                                                                                                                                                                                            |        | N/A                                                            |                                           | 10 mm (ER16, dry cut)<br>5.8 mm (ER16, wet cut) |
| Maximum Force (continuous)                                                                                                                                                                                                                                                                                                                                                                                                                                                                                                                                                                                                                                                                                                                                                                                                               |        | 197.2 N                                                        |                                           | N/A                                             |
| Maximum Torque (continuous)                                                                                                                                                                                                                                                                                                                                                                                                                                                                                                                                                                                                                                                                                                                                                                                                              |        | N/A                                                            |                                           | 2.3 N·m (dry cut)<br>1.6 N·m (wet cut)          |
| Load Capacity <sup>(2)</sup>                                                                                                                                                                                                                                                                                                                                                                                                                                                                                                                                                                                                                                                                                                                                                                                                             | Axial  | 3.0 kg                                                         |                                           |                                                 |
|                                                                                                                                                                                                                                                                                                                                                                                                                                                                                                                                                                                                                                                                                                                                                                                                                                          | Radial | 2.0 kg                                                         |                                           |                                                 |
|                                                                                                                                                                                                                                                                                                                                                                                                                                                                                                                                                                                                                                                                                                                                                                                                                                          | Moment | 3 N·m                                                          |                                           |                                                 |
| Moving Mass (unloaded)                                                                                                                                                                                                                                                                                                                                                                                                                                                                                                                                                                                                                                                                                                                                                                                                                   |        | 18 kg                                                          |                                           | N/A                                             |
| Rotor Inertia (unloaded)                                                                                                                                                                                                                                                                                                                                                                                                                                                                                                                                                                                                                                                                                                                                                                                                                 |        | N/A                                                            |                                           | 0.0006 kg·m <sup>2</sup>                        |
| Stage Mass with Tooling Platforms                                                                                                                                                                                                                                                                                                                                                                                                                                                                                                                                                                                                                                                                                                                                                                                                        |        | 65 kg                                                          | 69 kg                                     | N/A                                             |
| Collet Type <sup>(3)</sup>                                                                                                                                                                                                                                                                                                                                                                                                                                                                                                                                                                                                                                                                                                                                                                                                               |        | N/A                                                            |                                           | ER16                                            |
| Collet Runout <sup>(4)</sup>                                                                                                                                                                                                                                                                                                                                                                                                                                                                                                                                                                                                                                                                                                                                                                                                             |        | N/A                                                            |                                           | <25 µm                                          |
| Minimum System Air Pressure <sup>(5)</sup>                                                                                                                                                                                                                                                                                                                                                                                                                                                                                                                                                                                                                                                                                                                                                                                               |        | 100 psig                                                       |                                           |                                                 |
| Material                                                                                                                                                                                                                                                                                                                                                                                                                                                                                                                                                                                                                                                                                                                                                                                                                                 |        | Hardcoated Aluminum Stage Body<br>Stainless Steel Collet Chuck |                                           |                                                 |
| Mean Time Between Failure (MTBF)                                                                                                                                                                                                                                                                                                                                                                                                                                                                                                                                                                                                                                                                                                                                                                                                         |        | 10,000 Hours                                                   |                                           |                                                 |
| <p>1. Maximum speed is based on stage capability. Actual speed may be limited by system data rate, resolution, or amplifier selection.</p> <p>2. Maximum loads are mutually exclusive. Loading limits are due to the collet chuck mechanism. Contact Aerotech directly if part load requirement exceeds specifications.</p> <p>3. LaserTurn®5-ASR collet chuck accepts Rego-Fix ER collets manufactured to DIN6499 specifications only.</p> <p>4. Measured TIR of a precision gage pin chucked with an ultra-precision ER collet (DIN6499), 10 mm away from collet face.</p> <p>5. Collet chuck mechanism is normally-closed. Collet mechanism requires air to open collet chuck. Air supply must be dry (0°F dew-point) oil-less air OR 99.99% pure Nitrogen. Air or nitrogen must be filtered to 1 micron particle size or better.</p> |        |                                                                |                                           |                                                 |

*This page intentionally left blank.*

## Chapter 2: Installation



**WARNING:** LaserTurn<sup>®</sup>5-ASR installation must be in accordance to instructions provided by this manual and any accompanying documentation. Failure to follow these instructions could result in injury or damage to the equipment.

### 2.1. Unpacking and Handling the Stage

**NOTE:** If any damage has occurred during shipping, report it immediately.



**WARNING:** It is the customer's responsibility to safely and carefully lift the stage.

- Make sure that all moving parts are secure before moving the LaserTurn<sup>®</sup>5-ASR. Unsecured moving parts may shift and cause bodily injury.
- Improper handling could adversely affect the performance of the LaserTurn<sup>®</sup>5-ASR. Use care when moving the LaserTurn<sup>®</sup>5-ASR.
- Lift the stage only by the base at [QTY-4] 3/8-16 tapped holes. Do not use the stage table or motor as a lifting points.

Carefully remove the LaserTurn<sup>®</sup>5-ASR from its protective shipping container. Gently set the LaserTurn<sup>®</sup>5-ASR on a smooth, flat, and clean surface.

Before operating the LaserTurn<sup>®</sup>5-ASR, it is important to let it stabilize at room temperature for at least 12 hours. Allowing it to stabilize to room temperature will ensure that all of the alignments, preloads, and tolerances are the same as they were when tested at Aerotech. Use compressed nitrogen or clean, dry, oil-less air to remove any dust or debris that has collected during shipping.

Each LaserTurn<sup>®</sup>5-ASR has a label listing the system part number and serial number. These numbers contain information necessary for maintaining or updating system hardware and software. Locate this label and record the information for later reference.

Red, anodized aluminum shipping brackets have been installed to prevent unwanted motion and potential damage from occurring during shipment (see [Figure 2-1](#)). The brackets must be removed before the LaserTurn<sup>®</sup>5-ASR can be operated. The brackets are secured with M6 Socket Head Cap Screws and can be removed with a 5 mm hex wrench. Retain the brackets and hardware for future use.

Four 3/8-16 threaded holes are provided for attaching lifting equipment. See [Figure 2-2](#) for the location of the lifting points. The [QTY. 4] 3/8-16 bolts in these holes must extend up at least 2.5 inches (64 mm) in order to clear the stationary hardcover on the linear axis.

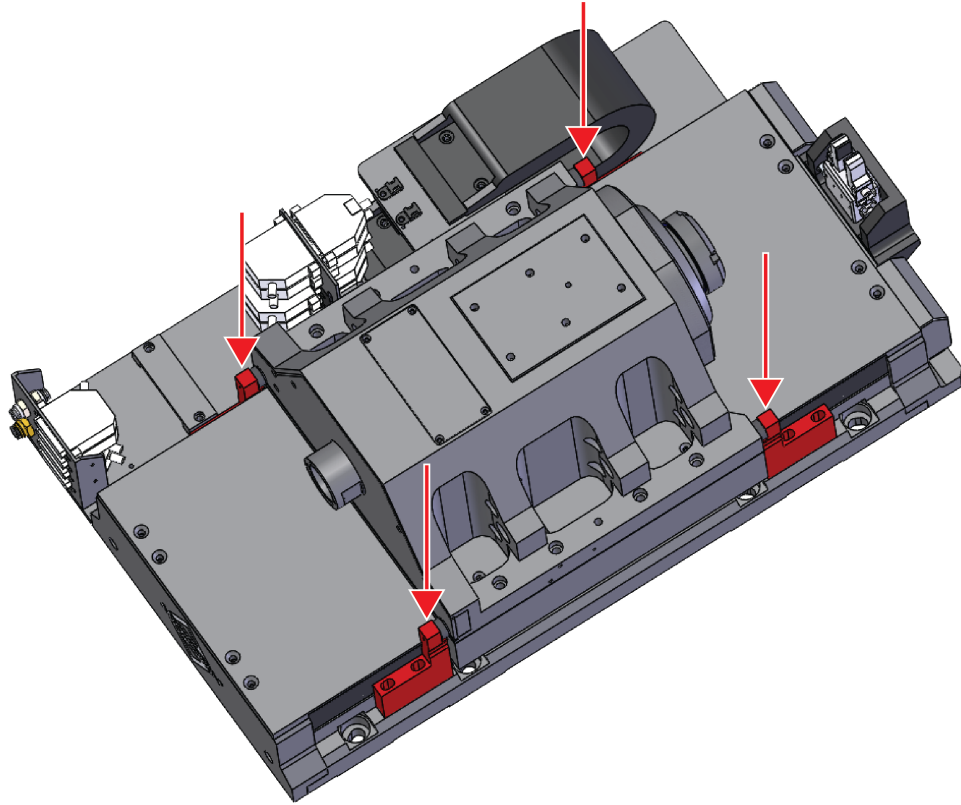

Figure 2-1: LaserTurn®5-ASR Shipping Clamps

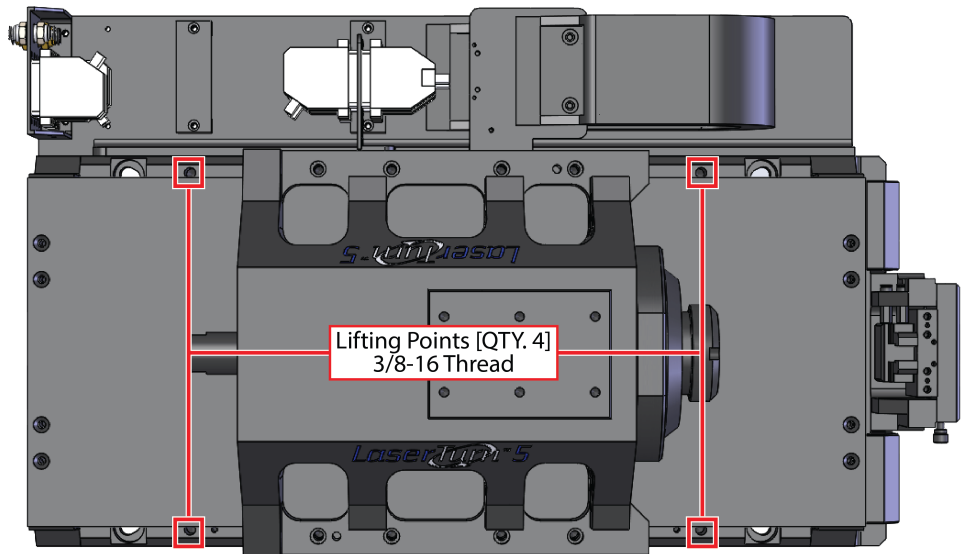
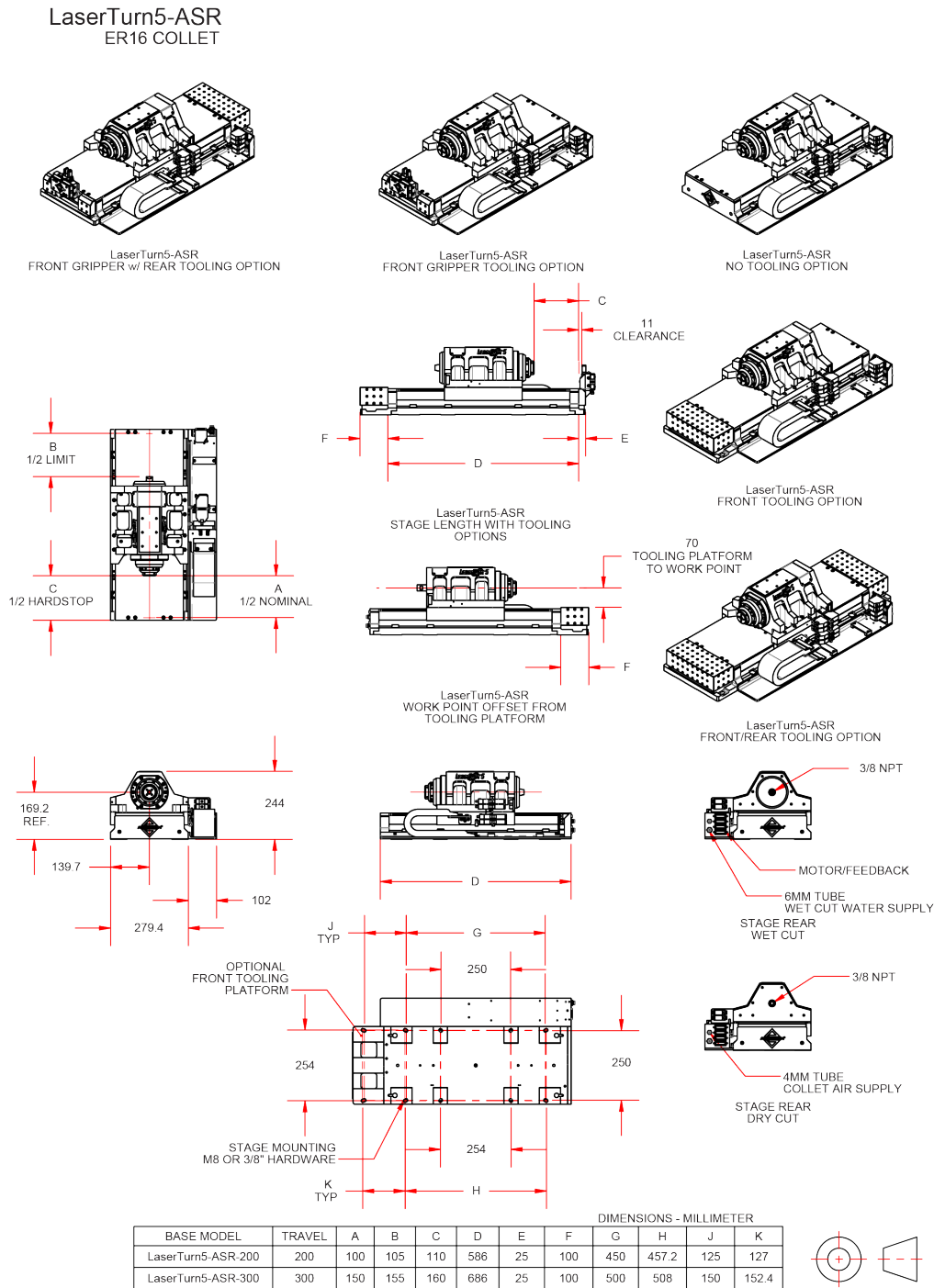

Figure 2-2: LaserTurn®5-ASR Lifting Points

## 2.2. Dimensions

**NOTE:** Aerotech continually improves its product offerings; listed options may be superseded at any time. All drawings and illustrations are for reference only and were complete and accurate as of this manual's release. Refer to [www.aerotech.com](http://www.aerotech.com) for the most up-to-date information.



**Figure 2-3: LaserTurn®5-ASR Dimensions (part one)**

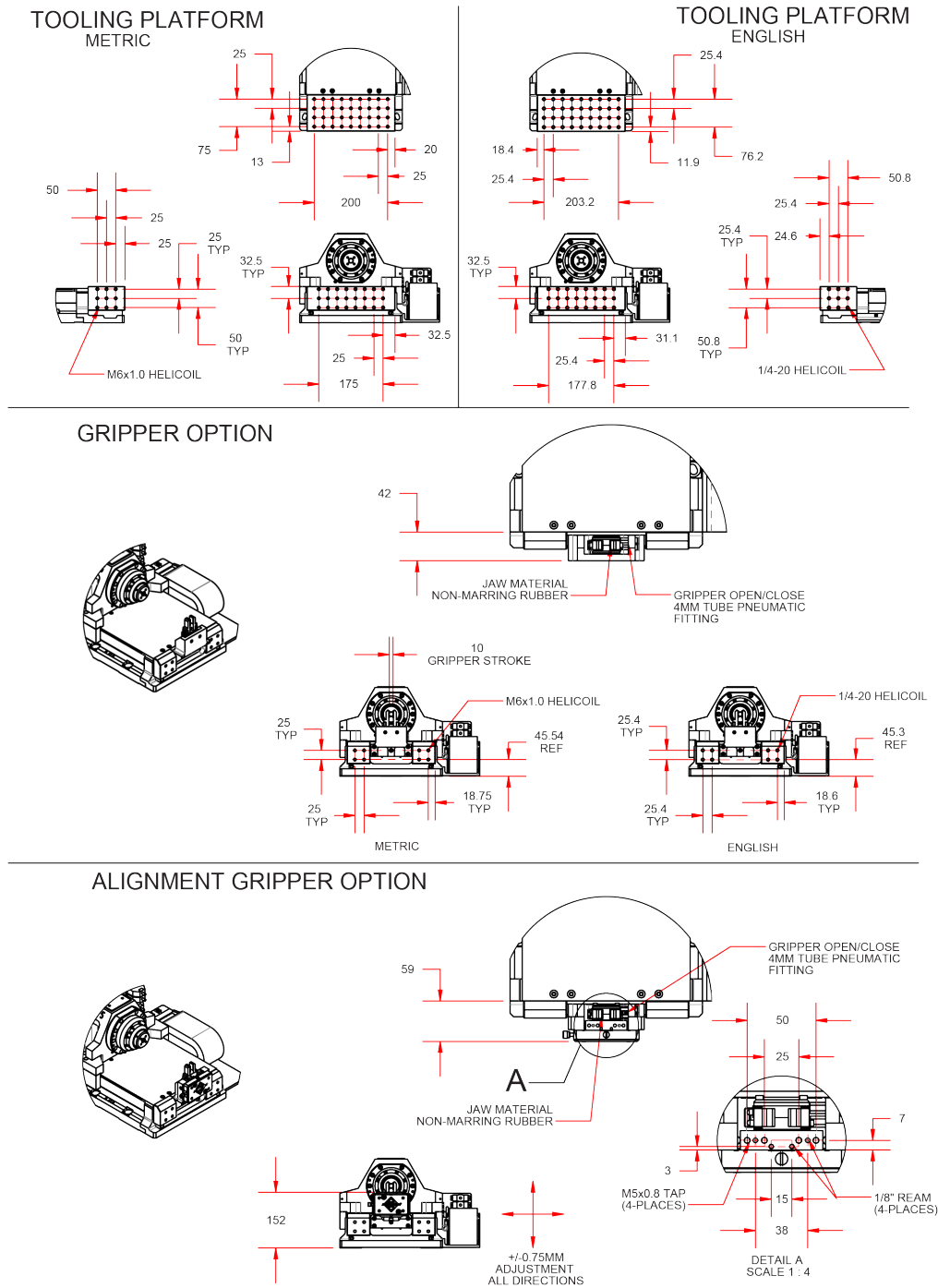

Figure 2-4: LaserTurn<sup>®</sup>5-ASR Dimensions (part two)



### 2.3. Securing the Stage to the Mounting Surface



**WARNING:** Do not attempt to manually move the LaserTurn<sup>®</sup>5-ASR if it is connected to a power source.



**WARNING:** Make sure that all moving parts are secure before moving the LaserTurn<sup>®</sup>5-ASR. Unsecured moving parts may shift and cause bodily injury.



**WARNING:** The LaserTurn<sup>®</sup>5-ASR must be mounted securely. Improper mounting can result in injury and damage to the equipment.



**DANGER: PINCH POINT!** Keep Hands Clear while the stage is in motion.

The mounting surface must be flat and have adequate stiffness in order to achieve the maximum performance from the LaserTurn<sup>®</sup>5-ASR stage. When it is mounted to a non-flat surface, the stage can be distorted as the mounting screws are tightened. This distortion will decrease overall accuracy. Adjustments to the mounting surface must be done before the stage is secured.

Inspect the mounting surface for dirt or unwanted residue and clean if necessary. Use precision flatstones on the mounting surface to remove any burrs or high spots. Clean the mounting surface with a lint-free cloth and acetone or isopropyl alcohol and allow the cleaning solvent to completely dry. Gently place the stage on the mounting surface.

**NOTE:** To maintain accuracy, the mounting surface must be flat to within 1  $\mu\text{m}$  per 50 mm.

**NOTE:** The LaserTurn<sup>®</sup>5-ASR is precision machined and verified for flatness prior to product assembly at the factory. If machining is required to achieve the desired flatness, it should be performed on the mounting surface rather than the LaserTurn<sup>®</sup>5-ASR. Shimming should be avoided if possible. If shimming is required, it should be minimized to retain maximum rigidity of the system.

Use the [QTY. 8] M8 or 5/16 SHCS (may have [QTY. 10 or 12] depending on selected options) to secure the stage to the mounting surface. Typical screw torque is 16.8 N·m. Move the stage carriage to access the base plate mounting holes (refer to [Figure 2-5](#)).

If the stage is equipped with optional tooling platforms, you must make sure that the stage base and tooling platforms are aligned correctly. If they are incorrectly aligned, stage performance can decrease, and damage to the stage can occur. To align the tooling platforms, loosen the [QTY. 2] M6 SHCS in each platform. This allows the tooling platform to sit flush on the mounting surface. Then re-tighten the [QTY. 2] M6 SHCS. Typical screw torque is 6.9 N·m. The stage is now ready to be secured to the mounting surface.



**WARNING:** Do not attempt to move the carriage (or table top) of the LaserTurn<sup>®</sup>5-ASR until the lifting and shipping brackets have been removed. Moving the carriage with the lifting and shipping brackets installed can cause permanent damage to the LaserTurn<sup>®</sup>5-ASR.

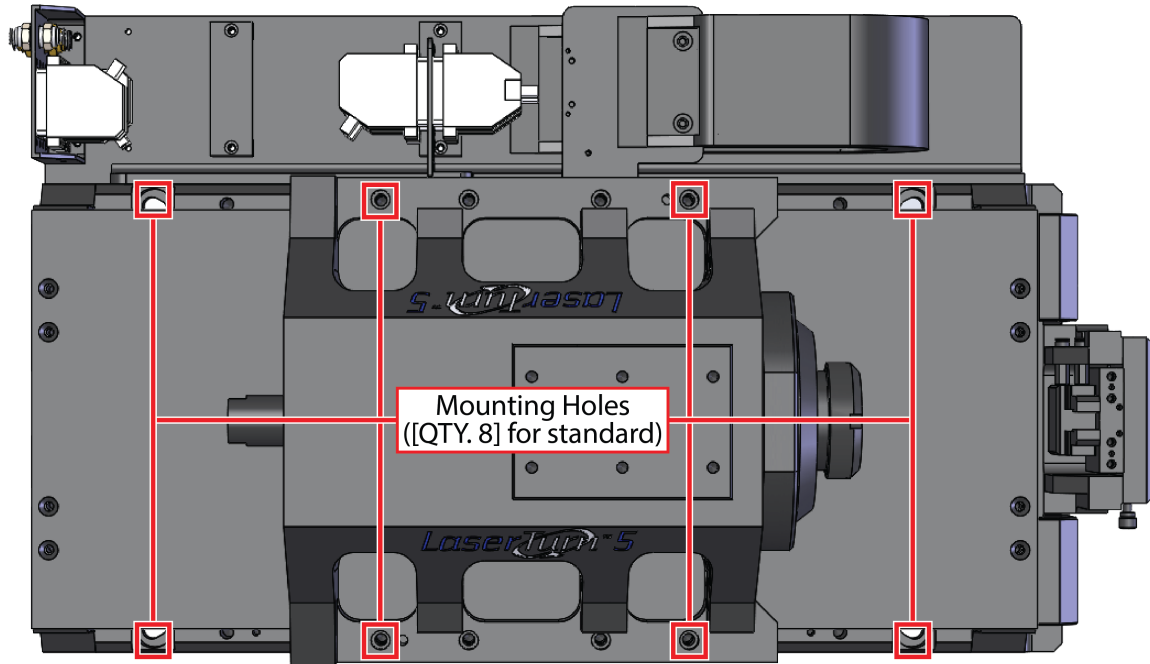

Figure 2-5: LaserTurn®5-ASR Stage Showing Mounting Holes (Top View)

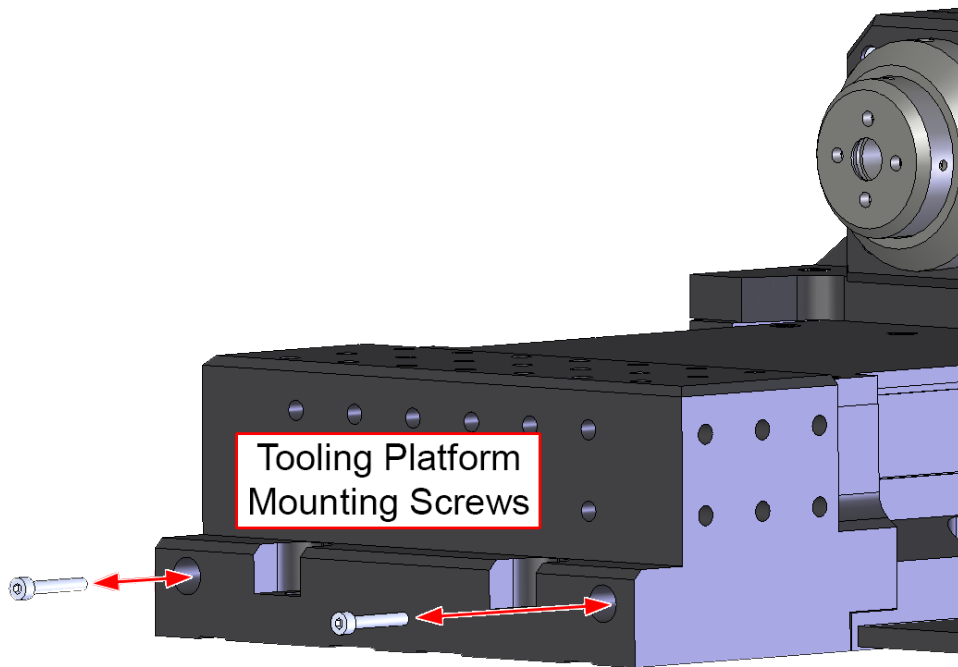

Figure 2-6: Tooling Platform Hardware

## 2.4. Air Requirements

The air pressure supplied to the collet holder is important in ensuring that the material or tool is released properly, or for the optional gripper, that the material is held securely.

- If compressed air is used, it must be filtered to 1 micron, dry to 0° F dew point, and oil free.
- If nitrogen is used, it must be 99.99% pure and filtered to 1 microns.

The chuck becomes fully open at approximately 4-5.5 bar (60-80 psig) depending on the collet size. Higher pressures will not cause damage to the rotary union, but high flow rates will result. Because of the noncontact rotary union design on collet-equipped stages, a small amount of leakage will occur. Approximate leakage rates of between 10 Lpm (0.5 CFM) and 40 Lpm (1.4 CFM), depending on pressure, will be observed when the collet is open.

**NOTE:** When operating the LaserTurn<sup>®</sup>5-ASR, supply 5 psi to the collet at all times. This will act as an air purge and help prevent contaminants from entering the rotary union.

## 2.5. Wet Cut Fluid Requirements

Water or cutting fluid used during wet cut operations must be conditioned to meet certain requirements ensuring seal functionality and service life of the wet cut rotary union.

- Water or cutting fluid must be filtered to 5 microns or better.
- A fluid filter must be installed upstream of the rotary union between the pump outlet and the rotary union inlet.

## 2.6. Attaching the Payload to the Stage

To prevent damage to the stage or parts, test the operation of the stage before any material is held in the collet or gripper. Proceed with the electrical installation and test the motion control system. Document all results for future reference. For information on electrical connections, refer to the documentation of the motion control system and [Chapter 3](#).

### Linear

The LaserTurn<sup>®</sup>5-ASR has optional front and rear tooling platforms. The surfaces of these platforms are precision surfaces that have been machined flat.

### Rotary

To operate the collet, clean compressed air or nitrogen must be supplied to the stage (refer to [Section 2.4](#)). The one-touch air inlet fitting accepts 4 mm OD plastic air line. Simply push the air line into the fitting and supply air to the stage. The CGF pneumatics kit option contains the required air supply components, such as valves, filters, and airlines.

Once air is supplied, material of the appropriate size can be placed in the collet. All collets supplied by Aerotech are clearly labeled with their clamping size range and collet style. Be sure to use only the correct size material in the collet. If an incorrect material size is clamped, the accuracy of the collet could be compromised. Refer to [Section 2.8.1](#) for collet installation.



**WARNING:** The size of material should match the collet size and be inserted into the collet at least 2/3 the length of the collet bore. Material that is larger or smaller than the collet or not inserted far enough into the collet will affect system performance, particularly material runout. In worst-case scenarios, the collet could be damaged and have to be replaced.

## 2.7. Load Capability

The LaserTurn<sup>®</sup>5-ASR is designed for tubular manufacturing applications. With this in mind, the tubes loaded into the collet chuck of the rotary axis must fall within the maximum load parameters in [Section 1.3](#).

**NOTE:** Maximum loads are mutually exclusive. Loading limits are due to the collet chuck mechanism. Contact Aerotech directly if part load requirement exceeds specifications.

If the LaserTurn<sup>®</sup>5-ASR is configured for wet cut, it will have a rotary union attached to the end of the rotary shaft ([Figure 2-7](#)). A 3/8 in NPT tapped hole is provided on the end of the rotary union shaft to allow for connecting a pressure vessel or extension tube. To prevent damage or performance degradation of the stage, the unsupported length and weight of the attached pressure vessel is limited.

**NOTE:** Aerotech recommends the following limitations on the size and weight of an unsupported pressure vessel:

- Length past end of rotary union (L): <250 mm
- Moment about end of rotary union (M): <1.0 N-m

If these limits are exceeded, it is recommended that an external steady-rest or support be implemented.

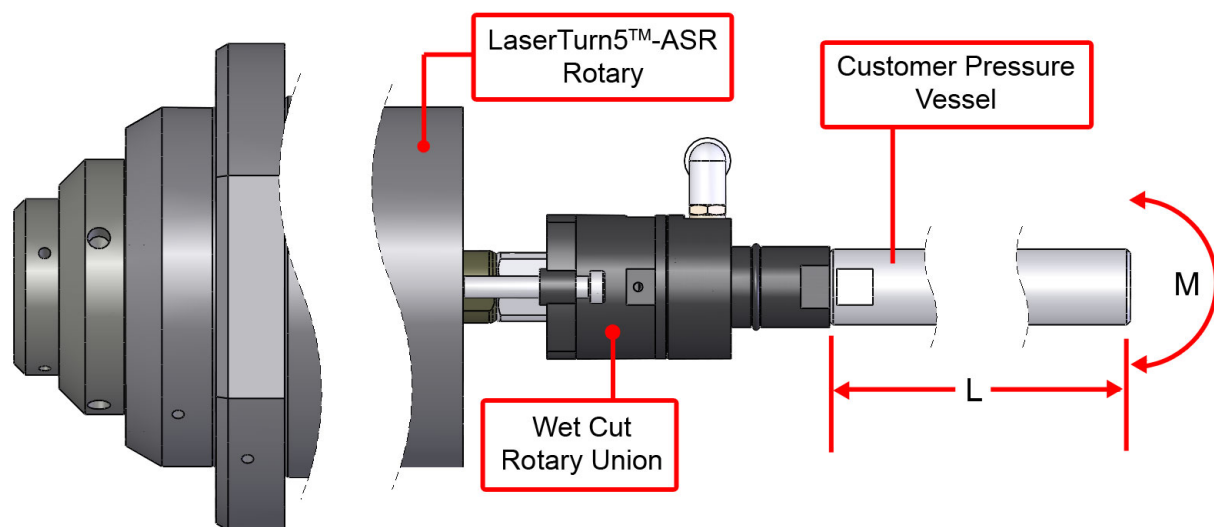

Figure 2-7: LaserTurn<sup>®</sup>5-ASR Wet Cut Rotary Union Location

## 2.8. Changing the Workholding Devices

LaserTurn®5-ASR stages may be equipped with ER16 style collets. It is important that only the collets designed for a particular collet holder are used. Contact the factory for more details.

**NOTE:** Aerotech recommends using only electro-polished collets manufactured to DIN6499 specifications.

**NOTE:** Various grip diameters are commonly available and can be interchanged.

### 2.8.1. Collet Installation and Removal Procedure



**DANGER:** To minimize the possibility of bodily injury or death, disconnect all electrical power prior to performing any maintenance or making adjustments to the equipment.

- Step 1: Remove power to the stage before installing or removing the collet.
- Step 2: Apply air pressure to loosen the collet chuck.
- Step 3: Remove the collet nut by turning it counterclockwise. If necessary, use a spanner wrench (available from Aerotech).

#### Install the Collet

- Step 4: Clean the collet housing, collet nut threads, collet nut, and new collet. Acetone or isopropyl alcohol can be used to clean the metal components. Apply a small amount of any anti-seize lubricant to the collet taper to help reduce friction and decrease wear (refer to section [Section 4.2.1.](#)).
- Step 5: Take note of the orientation of the spot drill on the back side of the collet nut, and refer to the instructions in [Figure 2-8](#) to install the collet.
- Step 6: Use the collet nut to guide the collet into the stage ([Figure 2-9](#)). Make sure that the collet is installed properly in its taper. Be sure that air pressure is still being supplied to the stage so the collet chuck is in the open position.
- Step 7: Tighten the collet nut. Tightening by hand is sufficient as the clamping force is not determined by the torque of the nut, but by the force of internal springs. Spanner wrenches may be used if desired.
- Step 8: Restore power to the stage.

#### Remove the Collet from the Collet Nut

- Step 9: Apply pressure to the front of the collet while tilting it towards the spot drill (refer to the installation steps in [Figure 2-8](#) for a visual reference).

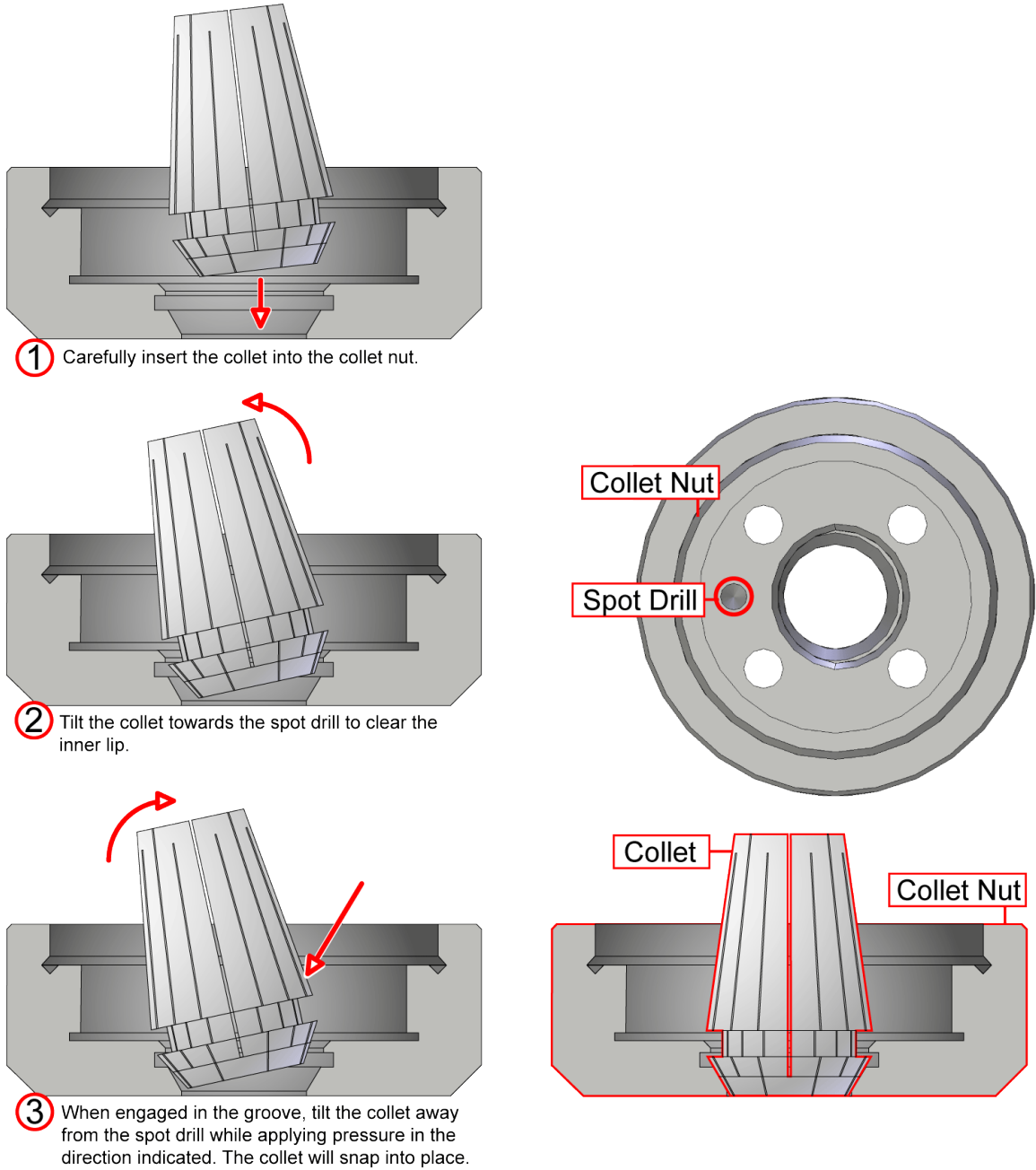

Figure 2-8: Inserting the Collet into the Collet Nut

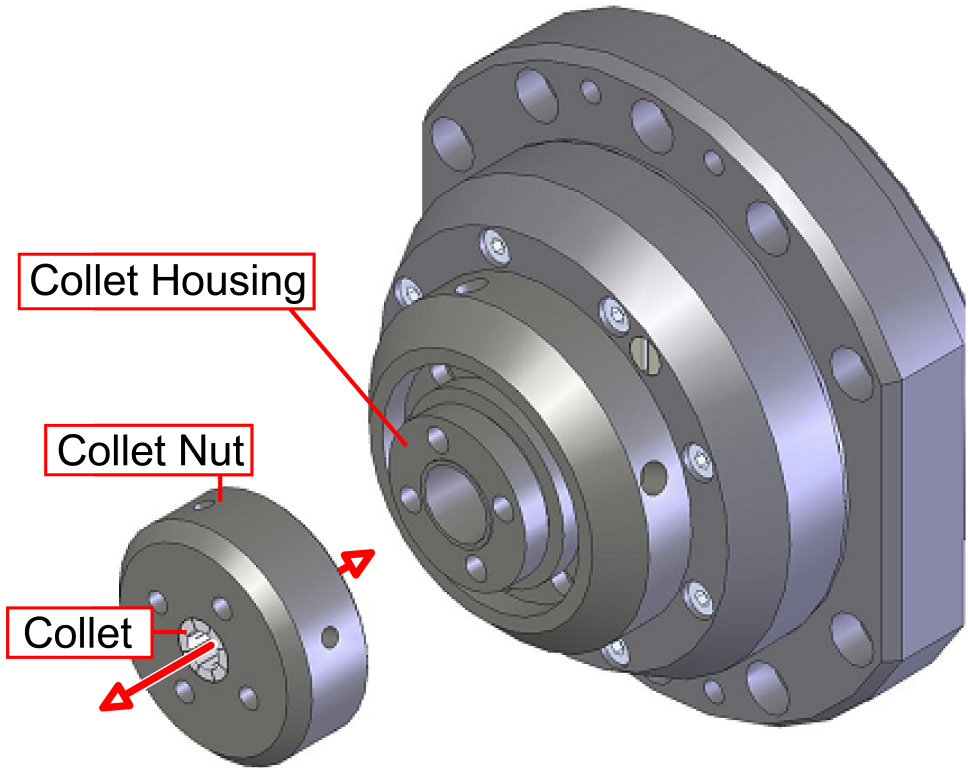

Figure 2-9: Installing the Collet and Collet Nut



## 2.9. Gripper Installation (-FT2)

This option equips the system with a parallel gripper for automated tube advancement and material handling.

Add the gripper option to LaserTurn<sup>®</sup>5-ASR systems with the steps that follow.

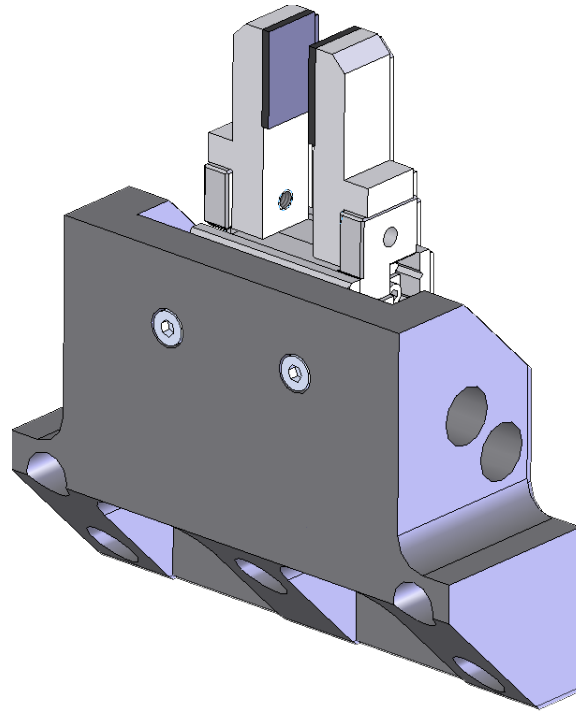

**Figure 2-10: Gripper Detail**

- Step 1: Set up the gripper on the front tooling platform.
- Step 2: Add [QTY-4] M6 socket head screws with washers.
- Step 3: Manually index the LaserTurn<sup>®</sup>5-ASR carriage toward the sub assembly and verify that there is no interference.
- Step 4: Slide the gripper as required using the provided slots in the bracket.
- Step 5: Connect the pneumatics kit to the gripper and adjust the operating pressure for desired grip force.

**NOTE:** Do not exceed 87 psi to the gripper on the open or closing cycle.

**NOTE:** Refer to the pneumatics layout drawing included with the documentation for assembly instructions.

## 2.10. Alignment Gripper Installation (-FT3 and -FT6)

This option equips a parallel gripper for automated tube advancement with a Y/Z adjustment stage. The adjustment stage has a travel range of  $\pm 0.75$  mm to help align the material support bushings (refer to [Figure 2-11](#)).

Use the steps that follow to attach the optional front tooling platform with alignment gripper to the LaserTurn<sup>®</sup>5-ASR.

Step 1: Set up the alignment gripper on the front tooling platform and reference it against the pins.

Step 2: Add [QTY-5] M6 socket head screws with washers.

**NOTE:** Make sure that the assembly is still referenced against 6 mm pins as described in Step 1.

Step 3: Manually index the carriage towards the subassembly and make sure that there is not interference.

Step 4: Attach the customer-supplied tube support to the alignment mechanism.

Step 5: Loosen the [QTY-2] M5 socket head locking screws shown in [Figure 2-11](#) so that the alignment mechanism can be adjusted.

Step 6: Feed the part into the collet and through the tube support bushing.

Step 7: Align the vertical and horizontal position of the bushing with the provided adjustment knobs.

Step 8: Secure the [QTY-2] M5 socket head locking screws that were loosened in Step 5.

Step 9: Connect the pneumatics kit (optional accessory with the CGF option or customer supplied) to the gripper and adjust the operating pressure for the desired grip force.

**NOTE:** Do not exceed 87 psi to the gripper on the open or closing cycle.

**NOTE:** Refer to the pneumatics layout drawing included with the documentation for assembly instructions.

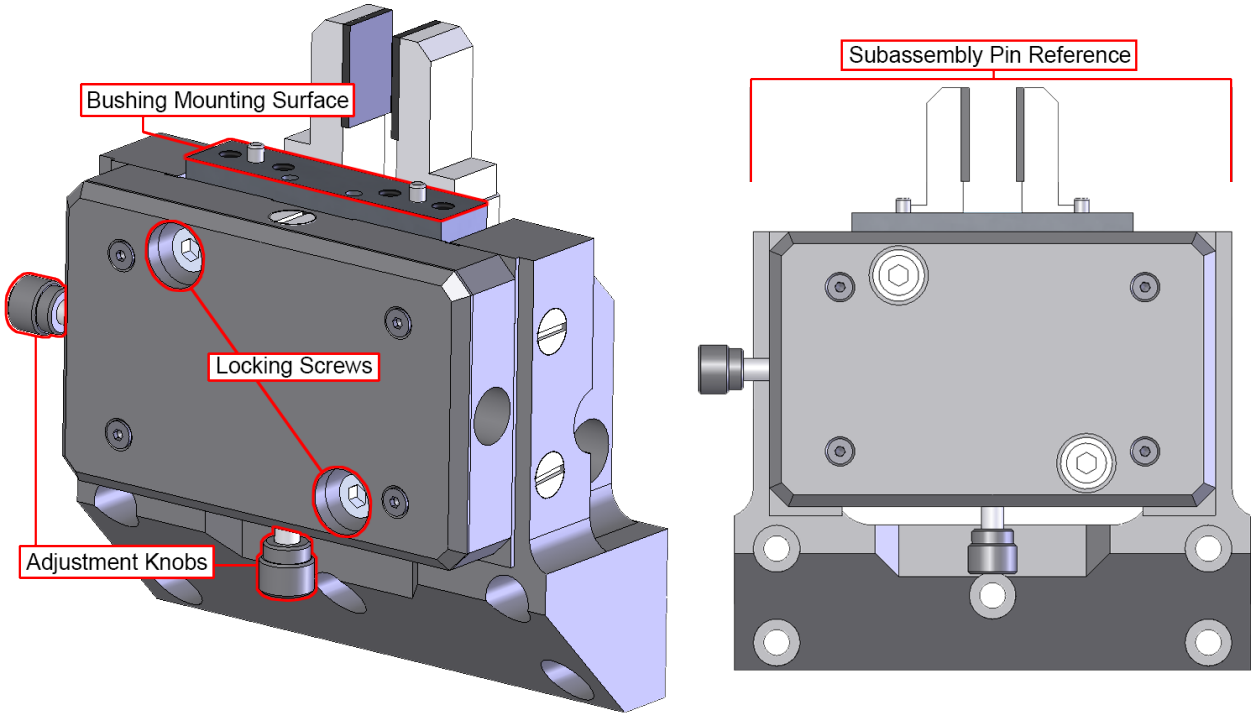
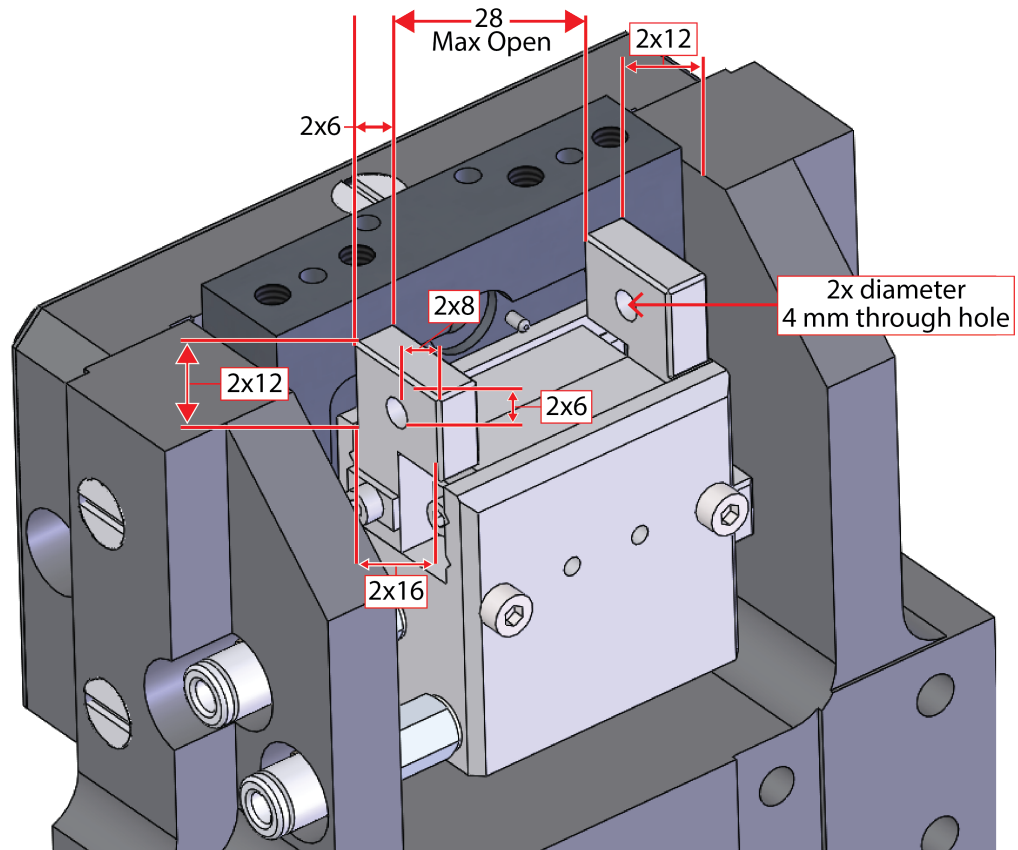

Figure 2-11: Alignment Gripper

## 2.11. Gripper Jaw Interface

Figure 2-12 shows the dimensions of the gripper jaw interface without the gripper jaws.



Dimensions: Millimeters

**Figure 2-12: Gripper Jaw Interface Dimensions**

## Chapter 3: Electrical Specifications and Installation



**WARNING:** Electrical installation must be performed by properly qualified personnel.

Aerotech motion control systems are adjusted at the factory for optimum performance. When the LaserTurn<sup>®</sup>5-ASR is part of a complete Aerotech motion control system, setup usually involves connecting the LaserTurn<sup>®</sup>5-ASR to the appropriate drive chassis with the cables provided. Labels on the system components usually indicate the appropriate connections.

If system level integration was purchased, an electrical drawing showing system interconnects has been supplied with the system (separate from this documentation).

The electrical wiring from the motor and encoder are integrated at the factory. Refer to the sections that follow for standard motor wiring and connector pinouts.



**WARNING:** Applications requiring access to the stage while it is energized will require additional grounding and safeguards. The System Integrator or qualified installer is responsible for determining and meeting all safety and compliance requirements necessary for the integration of this stage into the final application.



**DANGER:** Remove power before connecting or disconnecting electrical components or cables. Failure to do so may cause electric shock or damage to the equipment.



**WARNING:** Operator access to the base and tabletop must be restricted while connected to a power source. Failure to do so may cause electric shock.

### 3.1. Motor and Feedback Connectors

Stages equipped with standard motors and encoders come from the factory completely wired and assembled.

**NOTE:** Refer to the other documentation accompanying your Aerotech equipment. Call your Aerotech representative if there are any questions on system configuration.

**NOTE:** If using standard Aerotech motors and cables, motor and encoder connection adjustments are not required.



**DANGER:** Remove power before connecting or disconnecting electrical components or cables. Failure to do so may cause electric shock or damage to the equipment.



**WARNING:** The protective ground connection must be properly installed to minimize the possibility of electric shock.



**CAUTION:** The stage controller must provide over-current and over-speed protection. Failure to do so may result in permanent damage to the motor and stage components.

**Table 3-1: 4-Pin HPD Motor Connector Pinouts (for Rotary and Linear Axes)**

| Pin | Description                            | Connector |
|-----|----------------------------------------|-----------|
| A1  | Motor Phase A                          |           |
| A2  | Motor Phase B                          |           |
| A3  | Motor Phase C                          |           |
| 1   | Reserved                               |           |
| 2   | Reserved                               |           |
| 3   | Reserved                               |           |
| 4   | Reserved                               |           |
| 5   | Reserved                               |           |
| A4  | Frame ground (motor protective ground) |           |

**Table 3-2: 4-Pin D Motor Mating Connector**

| Mating Connector | Aerotech P/N | Third Party P/N         |
|------------------|--------------|-------------------------|
| Backshell        | ECK00656     | Amphenol #17E-1726-2    |
| Sockets [QTY. 4] | ECK00659     | ITT Cannon #DM53744-6   |
| Connector        | ECK00657     | ITT Cannon #DBM9W4SA197 |

**Table 3-3: 25-Pin D Feedback Connector Pinouts (Rotary Axis)**

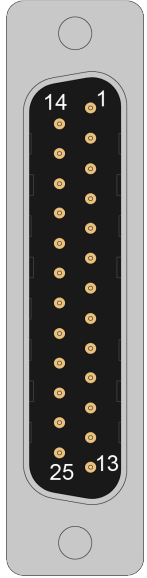
| Pin  | Description                                        | Connector                                                                            |
|------|----------------------------------------------------|--------------------------------------------------------------------------------------|
| 1    | Reserved                                           |  |
| 2    | Over-Temperature Thermistor sensor                 |                                                                                      |
| 3    | +5 V power supply (internally connected to Pin 16) |                                                                                      |
| 4    | Reserved                                           |                                                                                      |
| 5    | Hall Effect sensor, phase B                        |                                                                                      |
| 6    | Marker-N                                           |                                                                                      |
| 7    | Marker                                             |                                                                                      |
| 8    | Reserved                                           |                                                                                      |
| 9    | Reserved                                           |                                                                                      |
| 10   | Hall Effect sensor, phase A                        |                                                                                      |
| 11   | Hall Effect sensor, phase C                        |                                                                                      |
| 12   | Reserved                                           |                                                                                      |
| 13   | Reserved                                           |                                                                                      |
| 14   | Cosine                                             |                                                                                      |
| 15   | Cosine-N                                           |                                                                                      |
| 16   | +5 V power supply (internally connected to Pin 3)  |                                                                                      |
| 17   | Sine                                               |                                                                                      |
| 18   | Sine-N                                             |                                                                                      |
| 19   | Reserved                                           |                                                                                      |
| 20   | Common ground (internally connected to Pin 21)     |                                                                                      |
| 21   | Common ground (internally connected to Pin 20)     |                                                                                      |
| 22   | Reserved                                           |                                                                                      |
| 23   | Reserved                                           |                                                                                      |
| 24   | Reserved                                           |                                                                                      |
| 25   | Reserved                                           |                                                                                      |
| Case | Signal shield connection (to case)                 |                                                                                      |

**Table 3-4: 25-Pin D Feedback Mating Connector**

| Mating Connector | Aerotech P/N | Third Party P/N      |
|------------------|--------------|----------------------|
| Backshell        | ECK00656     | Amphenol #17E-1726-2 |
| Connector        | ECK00300     | FCI DB25S064TLF      |

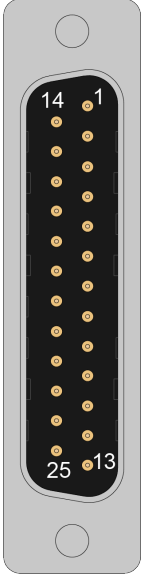

**Table 3-5: 25-Pin Feedback Connector Pinouts (Linear Axis)**

| Pin  | Description                                                               | Connector                                                                            |
|------|---------------------------------------------------------------------------|--------------------------------------------------------------------------------------|
| 1    | Reserved                                                                  |  |
| 2    | Over-Temperature Thermistor sensor                                        |                                                                                      |
| 3    | +5 V power supply (internally connected to Pin 16)                        |                                                                                      |
| 4    | Reserved                                                                  |                                                                                      |
| 5    | Hall Effect sensor, phase B                                               |                                                                                      |
| 6    | Marker-N                                                                  |                                                                                      |
| 7    | Marker                                                                    |                                                                                      |
| 8    | Reserved                                                                  |                                                                                      |
| 9    | Reserved                                                                  |                                                                                      |
| 10   | Hall Effect sensor, phase A                                               |                                                                                      |
| 11   | Hall Effect sensor, phase C                                               |                                                                                      |
| 12   | Signal indicating maximum travel produced by positive/CW stage direction. |                                                                                      |
| 13   | Reserved                                                                  |                                                                                      |
| 14   | Cosine                                                                    |                                                                                      |
| 15   | Cosine-N                                                                  |                                                                                      |
| 16   | +5 V power supply (internally connected to Pin 3)                         |                                                                                      |
| 17   | Sine                                                                      |                                                                                      |
| 18   | Sine-N                                                                    |                                                                                      |
| 19   | Reserved                                                                  |                                                                                      |
| 20   | Common ground (internally connected to Pin 21)                            |                                                                                      |
| 21   | Common ground (internally connected to Pin 20)                            |                                                                                      |
| 22   | Home limit output                                                         |                                                                                      |
| 23   | Reserved                                                                  |                                                                                      |
| 24   | Signal indicating maximum travel produced by negative/CCW stage direction |                                                                                      |
| 25   | Reserved                                                                  |                                                                                      |
| Case | Signal shield connection (to case)                                        |                                                                                      |

**Table 3-6: 25-Pin D Feedback Mating Connector**

| Mating Connector | Aerotech P/N | Third Party P/N      |
|------------------|--------------|----------------------|
| Backshell        | ECK00656     | Amphenol #17E-1726-2 |
| Connector        | ECK00300     | FCI DB25S064TLF      |

### 3.2. Motor and Feedback Wiring

All motor and controller manufacturers have their own designations for motor phases A/B/C and Hall signals A/B/C (refer to Section 3.5. for motor phasing). Shielded cables are required for the motor and feedback connections.

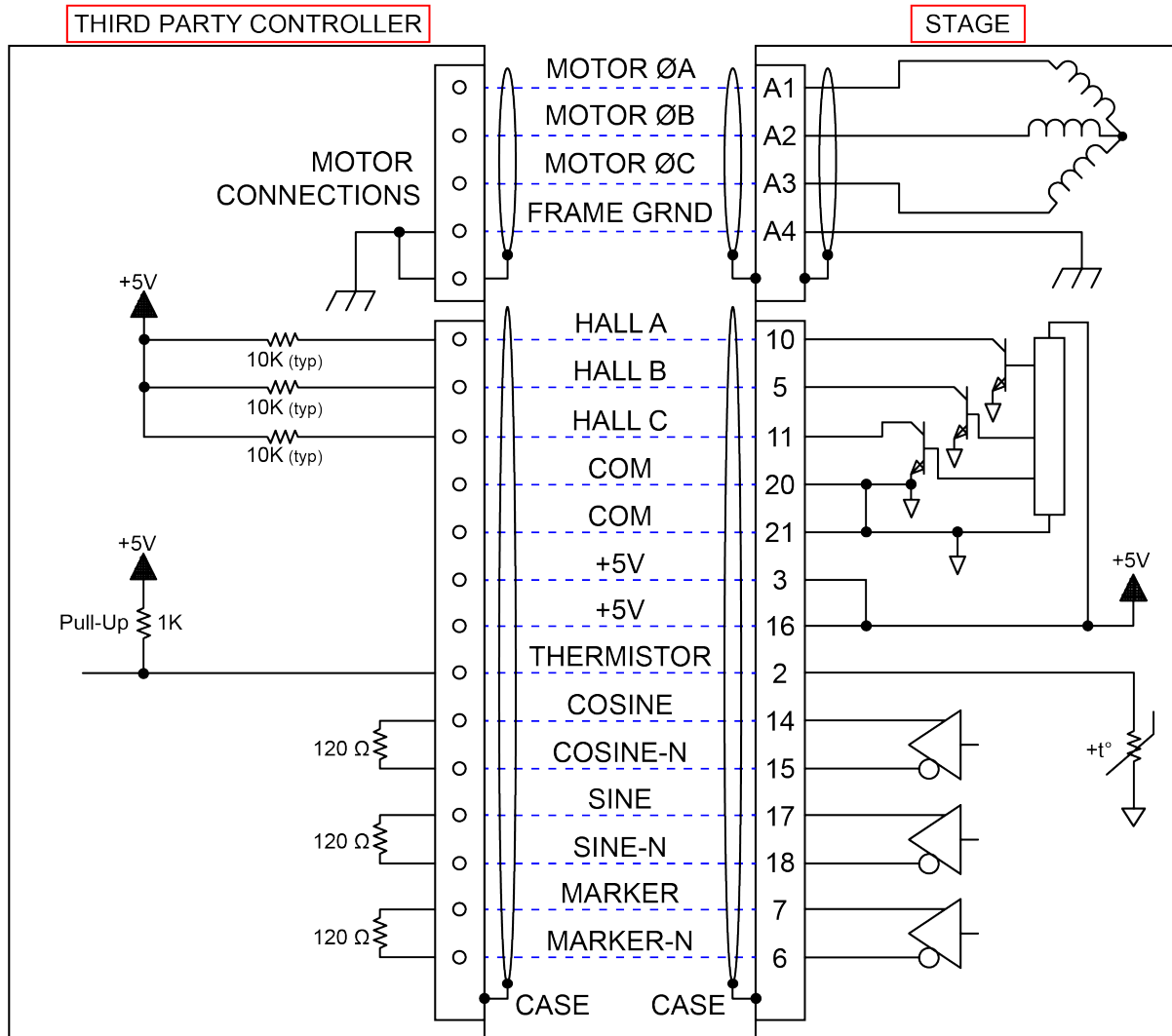
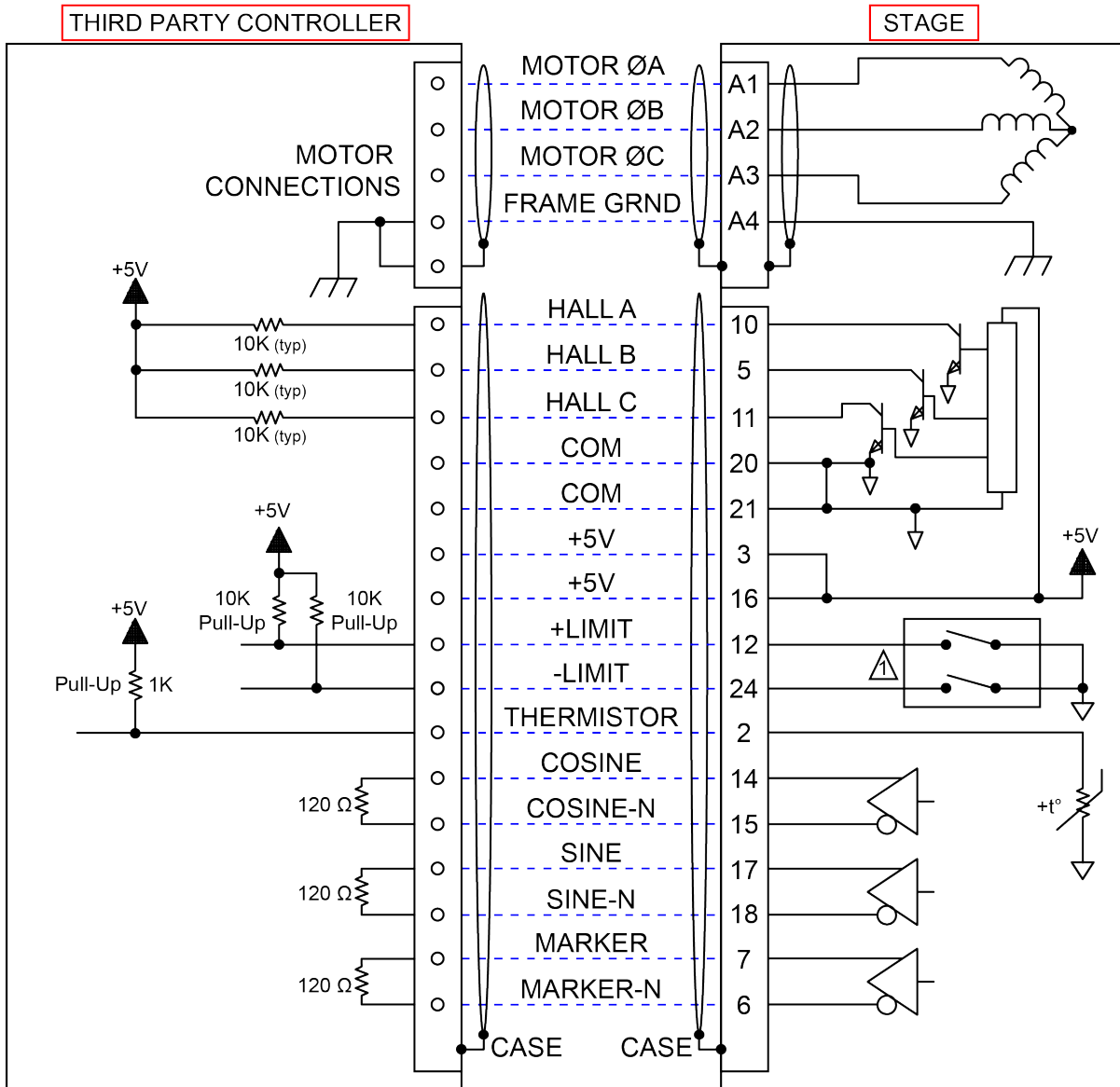

Figure 3-1: Motor and Feedback Wiring (Rotary Axis)



⚠ Over-travel limit switches are configured at the factory N.C. (normally closed)

**Figure 3-2: Motor and Feedback Wiring (Linear Axis)**

### 3.3. Motor and Feedback Specifications

**Table 3-7: Feedback Specifications**

| Hall-Effect Sensors Specifications |                    |
|------------------------------------|--------------------|
| Supply Voltage                     | 5 V $\pm$ 5%       |
| Supply Current                     | 50 mA              |
| Output Type                        | Open Collector     |
| Output Voltage                     | 24 V max (pull up) |
| Output Current                     | 5 mA (sinking)     |

| Thermistor Specifications                   |                                    |
|---------------------------------------------|------------------------------------|
| Polarity                                    | Logic "0" (no fault)               |
|                                             | Logic "1" (over-temperature fault) |
| Cold Resistance                             | $\sim$ 100 $\Omega$                |
| Hot Resistance                              | $\sim$ 10 K                        |
| <b>Note:</b> 1K pull-up to +5V recommended. |                                    |

| Encoder Specifications |                                                                                                                                                                                       |
|------------------------|---------------------------------------------------------------------------------------------------------------------------------------------------------------------------------------|
| Supply Voltage         | 5 V $\pm$ 5%                                                                                                                                                                          |
| Supply Current         | 250 mA (typical)                                                                                                                                                                      |
| Output Signals         | <b>Sinusoidal Type (Incremental Encoder):</b> 1 V <sub>pk-pk</sub> into 120 $\Omega$ Load (differential signals SIN+, SIN-, COS+, COS- are .5 V <sub>pk-pk</sub> relative to ground.) |
| Rotary Axis            | Incremental Sine - 8192 lines per revolution (Fundamental)                                                                                                                            |
| Linear Axis (-E1)      | Incremental Sine - 20 $\mu$ m resolution (Fundamental)                                                                                                                                |
| Linear Axis (-E2)      | Incremental Sine - 4 $\mu$ m resolution (Fundamental)                                                                                                                                 |

| Limit Switch Specifications                                                                                                                                                             |                                                                                                                                                                                                                                                                 |
|-----------------------------------------------------------------------------------------------------------------------------------------------------------------------------------------|-----------------------------------------------------------------------------------------------------------------------------------------------------------------------------------------------------------------------------------------------------------------|
| Supply Voltage                                                                                                                                                                          | 5 V $\pm$ 5%                                                                                                                                                                                                                                                    |
| Supply Current                                                                                                                                                                          | 25 mA                                                                                                                                                                                                                                                           |
| Output Type                                                                                                                                                                             | Open Collector                                                                                                                                                                                                                                                  |
| Output Voltage                                                                                                                                                                          | 5 V                                                                                                                                                                                                                                                             |
| Output Current                                                                                                                                                                          | 10 mA (sinking)                                                                                                                                                                                                                                                 |
| Output Polarity                                                                                                                                                                         | Normally Closed (NC) <ul style="list-style-type: none"> <li>Sinks current to ground (Logic "0") when not in limit</li> <li>High impedance (Logic "1") when in limit</li> <li>Requires external pull-up to +5 V (10 k<math>\Omega</math> recommended)</li> </ul> |
| <b>Notes:</b>                                                                                                                                                                           |                                                                                                                                                                                                                                                                 |
| 1. If the LaserTurn®5-ASR is driven beyond the electrical limit, it will encounter a mechanical stop. Impacting the mechanical stop could cause damage to the stage even at low speeds. |                                                                                                                                                                                                                                                                 |

**Table 3-8: Rotary Axis Motor Specifications (BM250)**

|                                                                                                                                                                                                                                                                                                                                                                                                                                                                                                                                                                                                                                                                                                                              |                                        | BM250            |
|------------------------------------------------------------------------------------------------------------------------------------------------------------------------------------------------------------------------------------------------------------------------------------------------------------------------------------------------------------------------------------------------------------------------------------------------------------------------------------------------------------------------------------------------------------------------------------------------------------------------------------------------------------------------------------------------------------------------------|----------------------------------------|------------------|
| <b>Performance Specifications (1,2)</b>                                                                                                                                                                                                                                                                                                                                                                                                                                                                                                                                                                                                                                                                                      |                                        |                  |
| Stall Torque, Continuous <sup>(3)</sup>                                                                                                                                                                                                                                                                                                                                                                                                                                                                                                                                                                                                                                                                                      | N·m (oz·in)                            | 2.3 (322)        |
| Peak Torque <sup>(4)</sup>                                                                                                                                                                                                                                                                                                                                                                                                                                                                                                                                                                                                                                                                                                   | N·m (oz·in)                            | 5.7 (805)        |
| Rated Power Output, Continuous                                                                                                                                                                                                                                                                                                                                                                                                                                                                                                                                                                                                                                                                                               | W                                      | 739              |
| <b>Electrical Specifications (2)</b>                                                                                                                                                                                                                                                                                                                                                                                                                                                                                                                                                                                                                                                                                         |                                        |                  |
| BEMF Constant (Line-Line, Max)                                                                                                                                                                                                                                                                                                                                                                                                                                                                                                                                                                                                                                                                                               | $V_{pk}/k_{rpm}$                       | 28               |
| Continuous Current, Stall <sup>(3)</sup>                                                                                                                                                                                                                                                                                                                                                                                                                                                                                                                                                                                                                                                                                     | $A_{pk} (A_{rms})$                     | 10.3 (7.2)       |
| Peak Current, Stall <sup>(4)</sup>                                                                                                                                                                                                                                                                                                                                                                                                                                                                                                                                                                                                                                                                                           | $A_{pk} (A_{rms})$                     | 25.6 (18.1)      |
| Torque Constant <sup>(5)</sup>                                                                                                                                                                                                                                                                                                                                                                                                                                                                                                                                                                                                                                                                                               | $N·m/A_{pk}$<br>(oz·in/ $A_{pk}$ )     | 0.22<br>(31.4)   |
|                                                                                                                                                                                                                                                                                                                                                                                                                                                                                                                                                                                                                                                                                                                              | $N·m/A_{rms}$<br>(oz·in/ $A_{rms}$ )   | 0.31<br>(44.4)   |
| Motor Constant <sup>(3,5)</sup>                                                                                                                                                                                                                                                                                                                                                                                                                                                                                                                                                                                                                                                                                              | $N·m/\sqrt{W}$<br>(oz·in/ $\sqrt{W}$ ) | 0.198<br>(28.04) |
| Resistance, 25°C (Line-Line)                                                                                                                                                                                                                                                                                                                                                                                                                                                                                                                                                                                                                                                                                                 | $\Omega$                               | 1.1              |
| Inductance (Line-Line)                                                                                                                                                                                                                                                                                                                                                                                                                                                                                                                                                                                                                                                                                                       | mH                                     | 2.74             |
| Maximum Bus Voltage                                                                                                                                                                                                                                                                                                                                                                                                                                                                                                                                                                                                                                                                                                          | $V_{DC}$                               | 340              |
| Thermal Resistance                                                                                                                                                                                                                                                                                                                                                                                                                                                                                                                                                                                                                                                                                                           | °C/W                                   | 0.99             |
| Number of Poles                                                                                                                                                                                                                                                                                                                                                                                                                                                                                                                                                                                                                                                                                                              | --                                     | 8                |
| 1. Performance is dependent upon heat sink configuration, system cooling conditions, and ambient temperature<br>2. All performance and electrical specifications $\pm 10\%$<br>3. Values shown @ 105°C rise above a 25 °C ambient temperature, with housed motor mounted to a 250 mm x 250 mm x 6 mm aluminum heat sink<br>4. Peak torque assumes correct rms current; consult Aerotech<br>5. Torque constant and motor constant specified at stall<br>6. Maximum winding temperature is 130 °C<br>7. Ambient operating temperature range 0 °C - 25 °C; consult Aerotech for performance in elevated ambient temperatures<br>8. All Aerotech amplifiers are rated $A_{pk}$ ; use torque constant in $N·m/A_{pk}$ when sizing |                                        |                  |

**Table 3-9: Rotary Axis Motor Specifications, -WCUT (BM250)**

|                                                                                                                                                                                                                                                                                                                                                                                                                                                                                                                                                                                                                                                                                                                              |                                 | BM250        |
|------------------------------------------------------------------------------------------------------------------------------------------------------------------------------------------------------------------------------------------------------------------------------------------------------------------------------------------------------------------------------------------------------------------------------------------------------------------------------------------------------------------------------------------------------------------------------------------------------------------------------------------------------------------------------------------------------------------------------|---------------------------------|--------------|
| <b>Performance Specifications (1,2)</b>                                                                                                                                                                                                                                                                                                                                                                                                                                                                                                                                                                                                                                                                                      |                                 |              |
| Stall Torque, Continuous <sup>(3)</sup>                                                                                                                                                                                                                                                                                                                                                                                                                                                                                                                                                                                                                                                                                      | N·m (oz·in)                     | 1.6 (227)    |
| Peak Torque <sup>(4)</sup>                                                                                                                                                                                                                                                                                                                                                                                                                                                                                                                                                                                                                                                                                                   | N·m (oz·in)                     | 4.1 (581)    |
| Rated Power Output, Continuous                                                                                                                                                                                                                                                                                                                                                                                                                                                                                                                                                                                                                                                                                               | W                               | 739          |
| <b>Electrical Specifications<sup>(2)</sup></b>                                                                                                                                                                                                                                                                                                                                                                                                                                                                                                                                                                                                                                                                               |                                 |              |
| BEMF Constant (Line-Line, Max)                                                                                                                                                                                                                                                                                                                                                                                                                                                                                                                                                                                                                                                                                               | $V_{pk}/k_{rpm}$                | 20           |
| Continuous Current, Stall <sup>(3)</sup>                                                                                                                                                                                                                                                                                                                                                                                                                                                                                                                                                                                                                                                                                     | $A_{pk} (A_{rms})$              | 10.3 (7.2)   |
| Peak Current, Stall <sup>(4)</sup>                                                                                                                                                                                                                                                                                                                                                                                                                                                                                                                                                                                                                                                                                           | $A_{pk} (A_{rms})$              | 25.6 (18.1)  |
| Torque Constant <sup>(5)</sup>                                                                                                                                                                                                                                                                                                                                                                                                                                                                                                                                                                                                                                                                                               | $N·m/A_{pk} (oz·in/A_{pk})$     | 0.16 (22.5)  |
|                                                                                                                                                                                                                                                                                                                                                                                                                                                                                                                                                                                                                                                                                                                              | $N·m/A_{rms} (oz·in/(A_{rms}))$ | 0.23 (32.6)  |
| Motor Constant <sup>(3,5)</sup>                                                                                                                                                                                                                                                                                                                                                                                                                                                                                                                                                                                                                                                                                              | $N·m/\sqrt{W} (oz·in/\sqrt{W})$ | 0.141 (20.2) |
| Resistance, 25°C (Line-Line)                                                                                                                                                                                                                                                                                                                                                                                                                                                                                                                                                                                                                                                                                                 | $\Omega$                        | 1.1          |
| Inductance (Line-Line)                                                                                                                                                                                                                                                                                                                                                                                                                                                                                                                                                                                                                                                                                                       | mH                              | 1.39         |
| Maximum Bus Voltage                                                                                                                                                                                                                                                                                                                                                                                                                                                                                                                                                                                                                                                                                                          | $V_{DC}$                        | 340          |
| Thermal Resistance                                                                                                                                                                                                                                                                                                                                                                                                                                                                                                                                                                                                                                                                                                           | $^{\circ}C/W$                   | 0.99         |
| Number of Poles                                                                                                                                                                                                                                                                                                                                                                                                                                                                                                                                                                                                                                                                                                              | --                              | 8            |
| 1. Performance is dependent upon heat sink configuration, system cooling conditions, and ambient temperature<br>2. All performance and electrical specifications $\pm 10\%$<br>3. Values shown @ 105°C rise above a 25 °C ambient temperature, with housed motor mounted to a 250 mm x 250 mm x 6 mm aluminum heat sink<br>4. Peak torque assumes correct rms current; consult Aerotech<br>5. Torque constant and motor constant specified at stall<br>6. Maximum winding temperature is 130 °C<br>7. Ambient operating temperature range 0 °C - 25 °C; consult Aerotech for performance in elevated ambient temperatures<br>8. All Aerotech amplifiers are rated $A_{pk}$ ; use torque constant in $N·m/A_{pk}$ when sizing |                                 |              |

**Table 3-10: Linear Axis Motor Specifications (BLM-264-A)**

|                                                                                                                                                                                                                                                                                                                                                                                                                                                                                                                                                                                                                                                                                                                 |                                | BLM-264        |
|-----------------------------------------------------------------------------------------------------------------------------------------------------------------------------------------------------------------------------------------------------------------------------------------------------------------------------------------------------------------------------------------------------------------------------------------------------------------------------------------------------------------------------------------------------------------------------------------------------------------------------------------------------------------------------------------------------------------|--------------------------------|----------------|
| <b>Performance Specifications (1)(5)</b>                                                                                                                                                                                                                                                                                                                                                                                                                                                                                                                                                                                                                                                                        |                                |                |
| Continuous Force, 1.4 bar (20 psi) (2)                                                                                                                                                                                                                                                                                                                                                                                                                                                                                                                                                                                                                                                                          | N (lb)                         | 301.7 (67.8)   |
| Continuous Force, No Forced Cooling (2)                                                                                                                                                                                                                                                                                                                                                                                                                                                                                                                                                                                                                                                                         | N (lb)                         | 197.2 (44.3)   |
| Peak Force (3)                                                                                                                                                                                                                                                                                                                                                                                                                                                                                                                                                                                                                                                                                                  | N (lb)                         | 1206.6 (271.3) |
| <b>Electrical Specifications(5)</b>                                                                                                                                                                                                                                                                                                                                                                                                                                                                                                                                                                                                                                                                             |                                |                |
| Winding Designation                                                                                                                                                                                                                                                                                                                                                                                                                                                                                                                                                                                                                                                                                             | A / B                          | -A             |
| BEMF Constant (line-line, max)                                                                                                                                                                                                                                                                                                                                                                                                                                                                                                                                                                                                                                                                                  | V/(m/s) (V/(in/s))             | 44.46 (1.13)   |
| Continuous Current 1.4 bar (20 psi) (2)                                                                                                                                                                                                                                                                                                                                                                                                                                                                                                                                                                                                                                                                         | $A_{pk}$ ( $A_{rms}$ )         | 7.80 (5.52)    |
| Continuous Current, No Forced Cooling (2)                                                                                                                                                                                                                                                                                                                                                                                                                                                                                                                                                                                                                                                                       | $A_{pk}$ ( $A_{rms}$ )         | 5.10 (3.61)    |
| Peak Current, Stall (3)                                                                                                                                                                                                                                                                                                                                                                                                                                                                                                                                                                                                                                                                                         | $A_{pk}$ ( $A_{rms}$ )         | 31.20 (22.06)  |
| Force Constant, Sine Drive (4) (8)                                                                                                                                                                                                                                                                                                                                                                                                                                                                                                                                                                                                                                                                              | $N/A_{pk}$ (lb/ $A_{pk}$ )     | 38.67 (8.69)   |
|                                                                                                                                                                                                                                                                                                                                                                                                                                                                                                                                                                                                                                                                                                                 | $N/A_{rms}$ (lb/ $A_{rms}$ )   | 54.69 (12.30)  |
| Motor Constant (2)(4)                                                                                                                                                                                                                                                                                                                                                                                                                                                                                                                                                                                                                                                                                           | $N/\sqrt{W}$ (lb/ $\sqrt{W}$ ) | 16.39 (3.69)   |
| Resistance, 25°C (line-line)                                                                                                                                                                                                                                                                                                                                                                                                                                                                                                                                                                                                                                                                                    | $\Omega$                       | 5.3            |
| Inductance (line-line)                                                                                                                                                                                                                                                                                                                                                                                                                                                                                                                                                                                                                                                                                          | mH                             | 4.20           |
| Thermal Resistance, 1.4 bar (20 psi)                                                                                                                                                                                                                                                                                                                                                                                                                                                                                                                                                                                                                                                                            | °C/W                           | 0.30           |
| Thermal Resistance, No Forced Cooling                                                                                                                                                                                                                                                                                                                                                                                                                                                                                                                                                                                                                                                                           | °C/W                           | 0.69           |
| Maximum Bus Voltage                                                                                                                                                                                                                                                                                                                                                                                                                                                                                                                                                                                                                                                                                             | $V_{DC}$                       | 340            |
| Magnetic Pole Pitch                                                                                                                                                                                                                                                                                                                                                                                                                                                                                                                                                                                                                                                                                             | mm (in)                        | 30.48 (1.20)   |
| 1. Performance is dependent upon heat sink configuration, system cooling conditions, and ambient temperature<br>2. Values shown @ 100°C rise above a 25°C ambient temperature, with motor mounted to the specified aluminum heat sink.<br>3. Peak force assumes correct rms current; consult Aerotech.<br>4. Force constant and motor constant specified at stall<br>5. All performance and electrical specifications $\pm 10\%$<br>6. Maximum winding temperature is 125°C.<br>7. Ambient operating temperature range 0 °C - 25 °C; consult Aerotech for performance in elevated ambient temperatures<br>8. All Aerotech amplifiers are rated $A_{pk}$ ; use force constant in $N \cdot m/A_{pk}$ when sizing. |                                |                |

### 3.4. Limits, Marker, and Machine Direction

Aerotech stages are configured to have positive and negative "machine" directions. The machine direction defines the phasing of the feedback and motor signals and is dictated by the stage wiring (refer to [Section 3.5](#) for Motor and Feedback phasing information). Programming direction of a stage is set by the controller that is used to move the stage. Programming direction is typically selectable in the controller, while machine direction is hardwired in the stage. [Figure 3-3](#) shows the machine direction of LaserTurn®5-ASR stages.

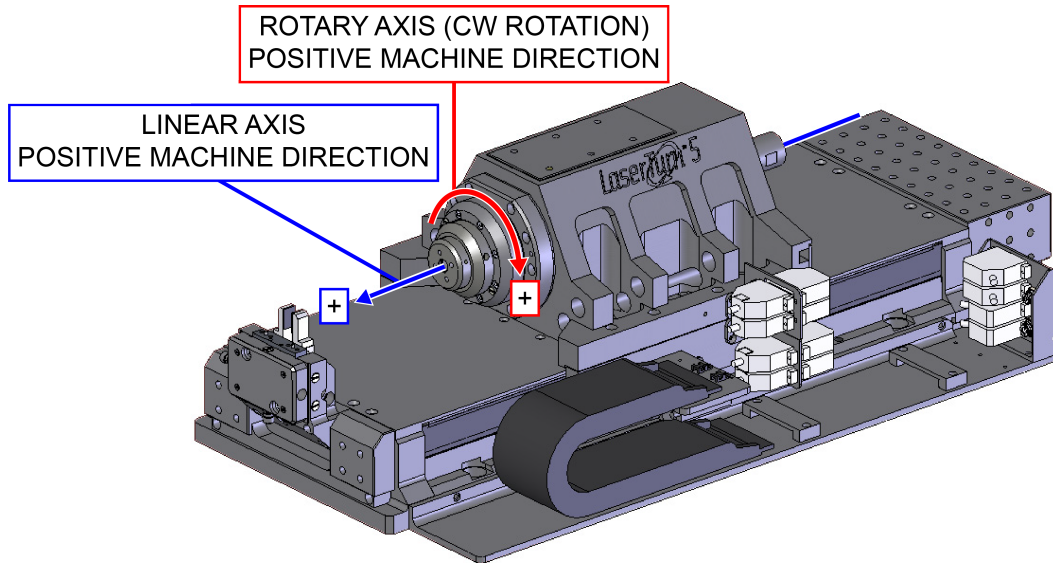
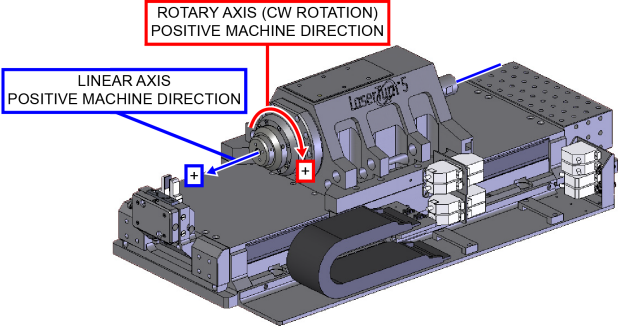
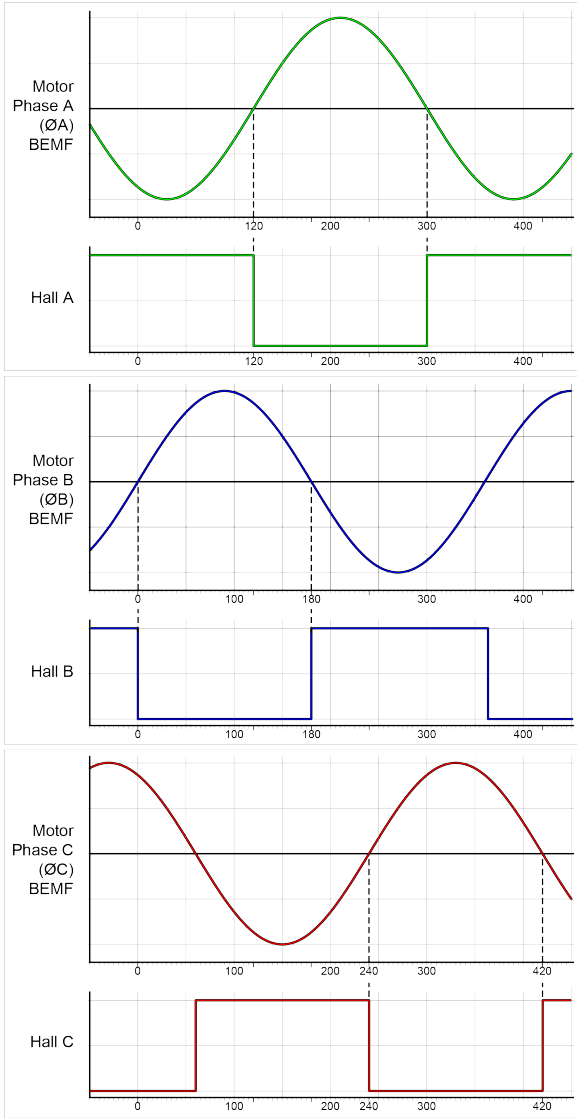

Figure 3-3: Machine Direction



### 3.5. Motor and Feedback Phasing

Motor phase voltage is measured relative to the virtual wye common point.



Positive MOVE (Clockwise) →

Figure 3-4: Hall Phasing

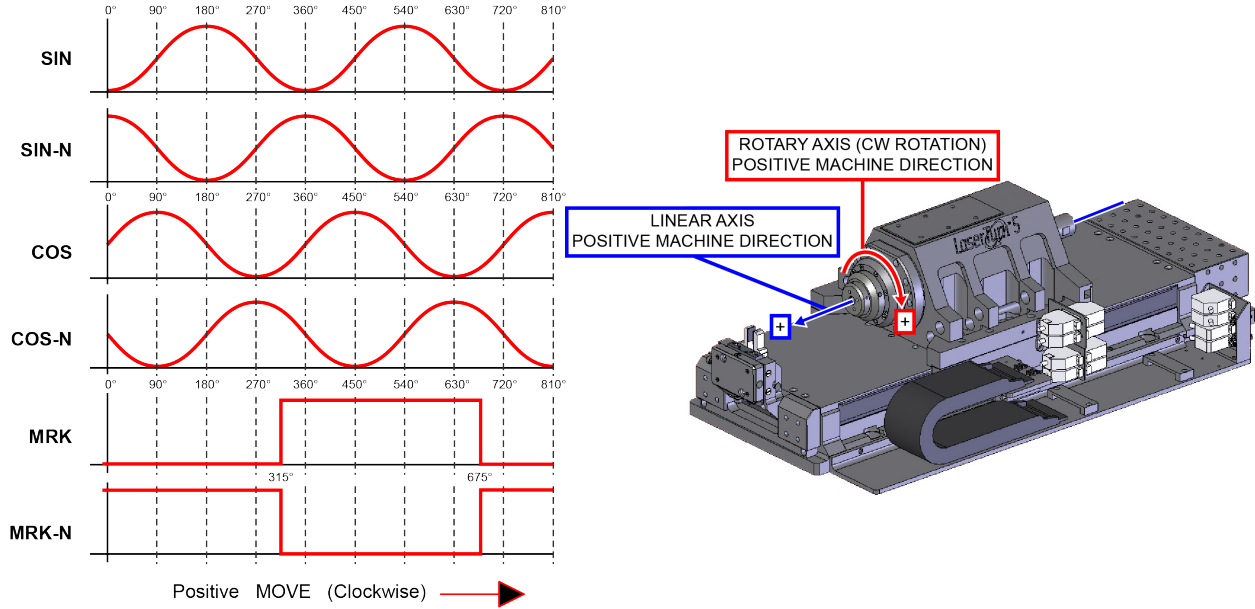

**Figure 3-5: Analog Encoder Phasing Reference Diagram**

## Chapter 4: Maintenance



**DANGER:** To minimize the possibility of bodily injury or death, disconnect all electrical power prior to performing any maintenance or making adjustments to the equipment.



**WARNING:** Failure to follow the maintenance procedures outlined in this section will result in voiding stage warranty.

### 4.1. Service and Inspection Schedule

Inspect the LaserTurn®5-ASR at least once per month. A longer or shorter inspection interval may be required depending on the specific application, and conditions such as the duty cycle, speed, and environment.

Rotary stage seals should be examined for excessive wear as part of this inspection interval. The application will determine the required replacement interval for the seals. The rotary stage bearings, motor, and encoder should require no lubrication or maintenance.

Monthly inspections should include but not be limited to:

- Visually inspect the stage and cables.
- Re-tighten loose connectors.
- Replace or repair damaged cables.
- Clean the LaserTurn®5-ASR and any components and cables as needed.
- Repair any damage before operating the LaserTurn®5-ASR.
- Inspect and perform an operational check on all safeguards and protective devices.

**NOTE:** For the wet cut option, replace the rotary seal before 1000 hours of service. Failure to follow the maintenance procedures outlined in [Section 4.3.3](#) will result in voiding of warranty.

**NOTE:** The bearing area must be kept free of foreign matter and moisture; otherwise, the performance and life expectancy of the stage will be reduced. Always operate the stage with the hard cover and side seals in place to help keep dirt out.

In general, stages operating in a clean environment should be cleaned and lubricated annually or every 500 km (whichever comes first). For stages operating under conditions involving excessive debris, the stage should be cleaned every six months. For high-speed applications (those near max speed at a duty cycle of 50%), frequent maintenance with standard lubricants is required.

## 4.2. Cleaning and Lubrication

### Cleaning

Before using a cleaning solvent on any part of the LaserTurn®5-ASR, blow away small particles and dust with nitrogen or, less preferably, clean, dry, compressed air.

Any external metal surface of the LaserTurn®5-ASR can be cleaned with isopropyl alcohol on a lint-free cloth. Harsher solvents, such as acetone, may damage the plastic and rubber seals on the linear bearing trucks.



**WARNING:** Make sure that all solvent has completely evaporated before attempting to move the stage.



**WARNING:** Acetone should never be used to clean the o-rings or seals.

### Lubrication

**NOTE:** During the lubrication procedure, inspect the linear motion guides for any damage or signs of wear.

If the application process uses only a small portion of travel for most of the duty cycle, periodically drive the stage through full travel to redistribute the lubrication in the bearings.

For more information about how to clean and lubricate the collet and collet chuck, refer to [Section 4.2.1. Collet & Collet Chuck Lubrication and Cleaning](#).

For more information about how to clean and lubricate the linear bearings, refer to [Section 4.2.2. Linear Lubrication and Cleaning Process](#).

For more information about how to lubricate the wet cut rotary union seals, refer to [Section 4.3.3. Wet Cut Rotary Union Seal Replacement](#).

### 4.2.1. Collet & Collet Chuck Lubrication and Cleaning



**WARNING:** Failure to lubricate and clean the collet interface surfaces will cause premature failure and wear that may void the warranty.

For the collet chuck and collet to operate properly, preventative maintenance and regular cleaning is required.

Before inserting any collet into the chuck, clean the chuck taper and the collet with acetone or isopropyl alcohol and a lint-free cloth or rag. If required, nitrogen or clean, dry, oil-less compressed air can be used to clean out the collet grooves. Inspect the collet and the chuck interface surfaces to be sure no wear marks are present. If wear or fret marks (copper colored oxide marks) are present, the taper can be lightly polished with a fine-grit crocus cloth. The goal is to clean the surface of the taper and not to remove an excessive amount of material. If the wear marks are large, or excessive polishing is required to remove these marks, the collet chuck and collet may need to be replaced. Contact Aerotech Technical Support for more information. Wear and fretting can be prevented with proper lubrication and maintenance intervals.

After inspection and cleaning, grease the collet chuck taper and collet taper with a small amount of lubricant. Then, install the collet into the collet chuck. Aerotech recommends using the lubricants listed in [Table 4-1](#).

**Table 4-1: Recommended Lubricants**

| Vender              | Product      | Item # | Description             |
|---------------------|--------------|--------|-------------------------|
| Henkel Technologies | Loctite      | 80209  | Silver Grade Anti-Seize |
| Henkel Technologies | Loctite      | 51168  | Food Grade Anti-Seize   |
| Jet Lube            | White Knight | 16404  | Food Grade Anti-Seize   |

Lubricant inspection and replenishment depend on application conditions such as collet chuck duty cycle, clamping force (air pressure), and the machining environment. An inspection interval of once every 8 operational hours is recommended until a trend develops for the application. Longer or shorter intervals may be required to maintain a film of lubricant on the collet taper. The collet and chuck should also be cleaned and relubricated after sitting for an extended period of time without operation. If the lubrication sits for long periods of time, it can become dry and lose its lubrication properties. Insufficient lubrication will lead to wear, fretting corrosion, and sticking or lock-up of the collet closer. If this occurs, the machine should be immediately stopped and the collet and collet chuck cleaned and relubricated. It is also recommended that the collet and chuck interface surfaces be cleaned, inspected, and relubricated every time the collet is removed.

### 4.2.2. Linear Lubrication and Cleaning Process

The lubrication and cleaning process is outlined in the steps that follow. The linear bearings are greased with Dow Corning BR-2. Do not mix lubricants due to potential incompatibilities.



**DANGER:** To minimize the possibility of bodily injury or death, disconnect all electrical power prior to performing any maintenance or making adjustments to the equipment.

- Step 1: Remove power to the stage.
- Step 2: Remove the hardcover (refer to [Section 4.5.](#)).
- Step 3: Remove any accumulated dust or debris from inside of the assembly.
- Step 4: Remove any dirty or dried lubricant from the linear bearing guides. Use a clean, lint-free cloth. A swab soaked in isopropyl alcohol can be used to remove stubborn debris.
- Step 5: Apply a thin, continuous film of lubricant to the linear bearing guides. A good quality, natural bristle artist's brush makes an excellent applicator.
- Step 6: Using the grease nipple on each linear bearing truck (refer to [Figure 4-1](#)), add grease as required.
- Step 7: Manually move the stage to the opposite end of travel to work the grease into the linear bearing guides.
- Step 8: Repeat steps 3 through 7 for any areas covered by the original table position.
- Step 9: Refasten the hardcover.
- Step 10: Restore power to the stage and drive the stage table back to its original position to redistribute lubricants.

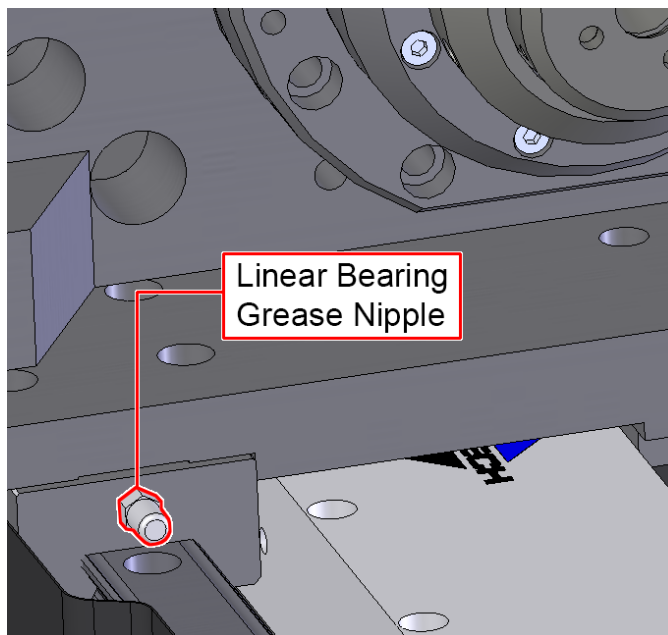

**Figure 4-1: Linear Bearing Grease Nipple**

## 4.3. Seal Replacement

### 4.3.1. Piston Seal Change Procedure

The collet chuck on the LaserTurn<sup>®</sup>5-ASR is equipped with o-ring piston seals that are designed to last many collet chuck (open/close) cycles. However, due to regular wear, the seals may require replacement during the lifetime of the product. If trouble with the piston seals is suspected, it is recommended that you contact Aerotech Technical Support. The seals should only be replaced by a qualified Aerotech technician.

### 4.3.2. Ringseal O-Ring Replacement

During the lifetime of the stage, it may be necessary to change the ringseal o-rings. Contact Aerotech to obtain proper replacement seals. Depending on the size, the ringseal may be one or two pieces. The ringseal screws into the center of the shaft from the front of the stage. Use the steps that follow to replace the o-ring.



**DANGER:** To minimize the possibility of bodily injury or death, disconnect all electrical power prior to performing any maintenance or making adjustments to the equipment.

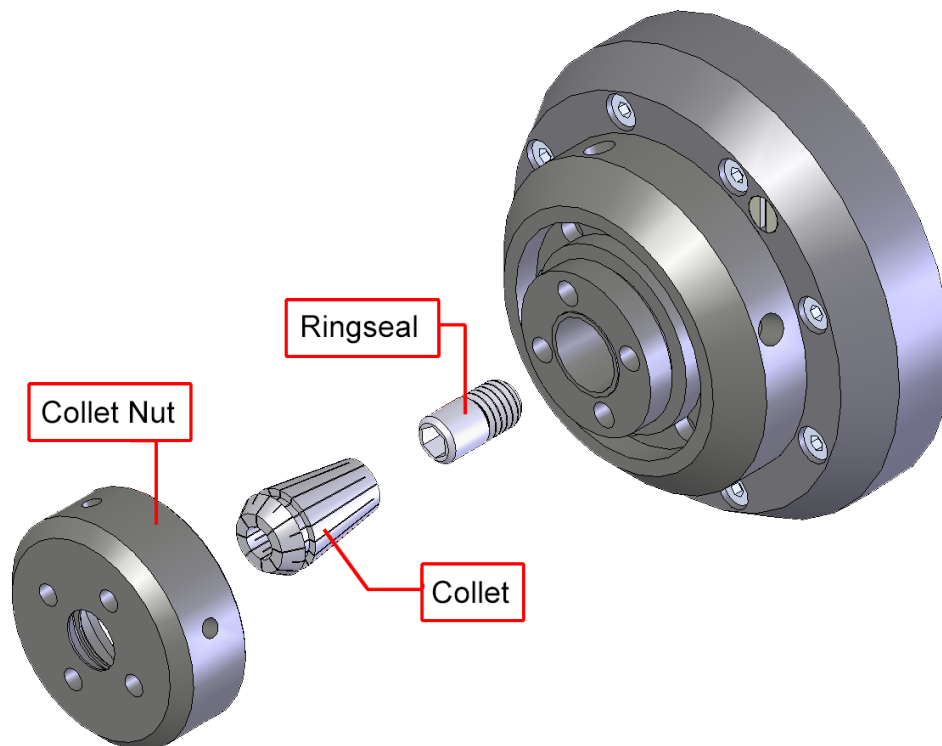
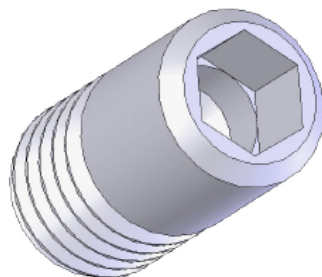
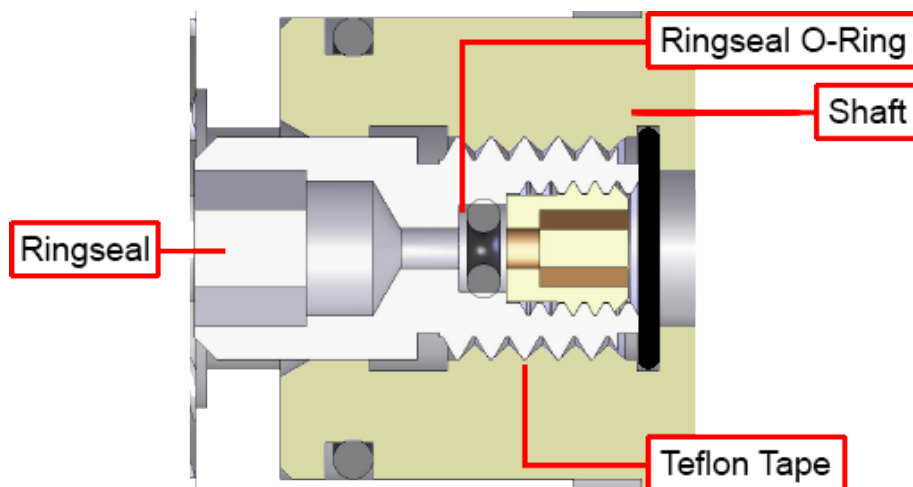

Figure 4-2: Ringseal Removal and Replacement



**Figure 4-3: Typical Ringseal**

- Step 1: Remove power to the stage.
- Step 2: Open the collet chuck. Since the collet holder is in the normally closed position, this will require air pressure supplied to the air inlet.
- Step 3: Once the collet has been released, unscrew the collet nut as shown in [Figure 4-2](#). If necessary, use a spanner wrench available from Aerotech.
- Step 4: With the collet and collet nut removed, the ringseal will now be exposed. Unscrew the ringseal from the shaft.
- Step 5: Remove the damaged or worn o-ring and replace it with a properly sized and lubricated new o-ring (shown in [Figure 4-4](#)). A long pick or thin screwdriver will be necessary to remove the o-ring and replace it. Contact Aerotech for the appropriate o-ring size and type.
- Step 6: Wrap the ringseal threads with Teflon thread sealing tape [PTFE tape] in preparation for installation.
- Step 7: Insert the ringseal into the inner collet housing and tighten into position.
- Step 8: Install the collet and collet nut.



**Figure 4-4: Cross-Section View of Ringseal Showing O-Ring**



### 4.3.3. Wet Cut Rotary Union Seal Replacement

The rotary seal in the wet cut rotary union requires periodic replacement. Contact Aerotech for obtaining appropriate replacement seals. [Figure 4-5](#) shows a cross section of the rotary union assembly.



**DANGER:** The wet cut rotary union seal should be replaced and relubricated at a minimum of every 1000 hours of stage operation.

**For heavy use or three shift operation:** this corresponds to replacement every month.

**For lighter use or single shift operation:** this corresponds to replacement every three months.



**WARNING:** Failure to follow the maintenance procedures outlined in this section will result in voiding stage warranty.



**DANGER:** To minimize the possibility of bodily injury or death, disconnect all electrical power prior to performing any maintenance or making adjustments to the equipment.

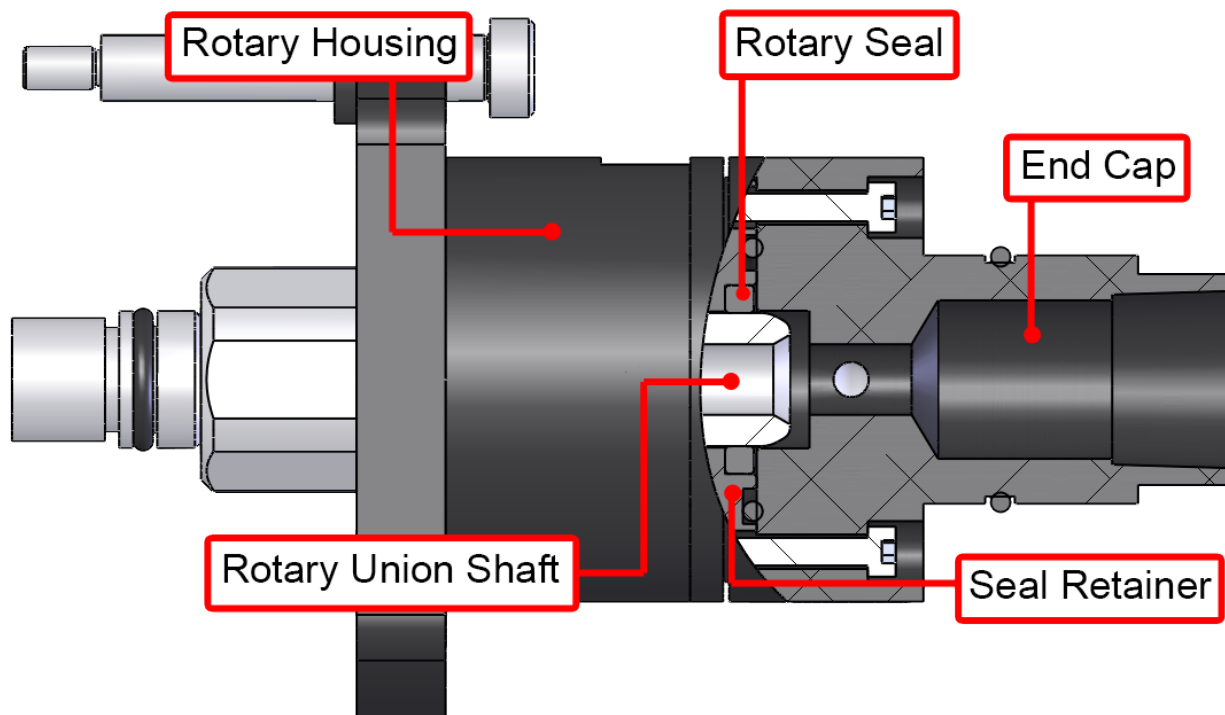

**Figure 4-5: Cross-Section View of Wet Cut Rotary Union**

Step 1: To access the rotary union assembly, remove the rear carriage cover and top carriage cover located on the backside of the carriage (see [Figure 4-6](#)). If necessary, insert [Qty-2] M4x0.7 screws into the rear cover to help with removal.

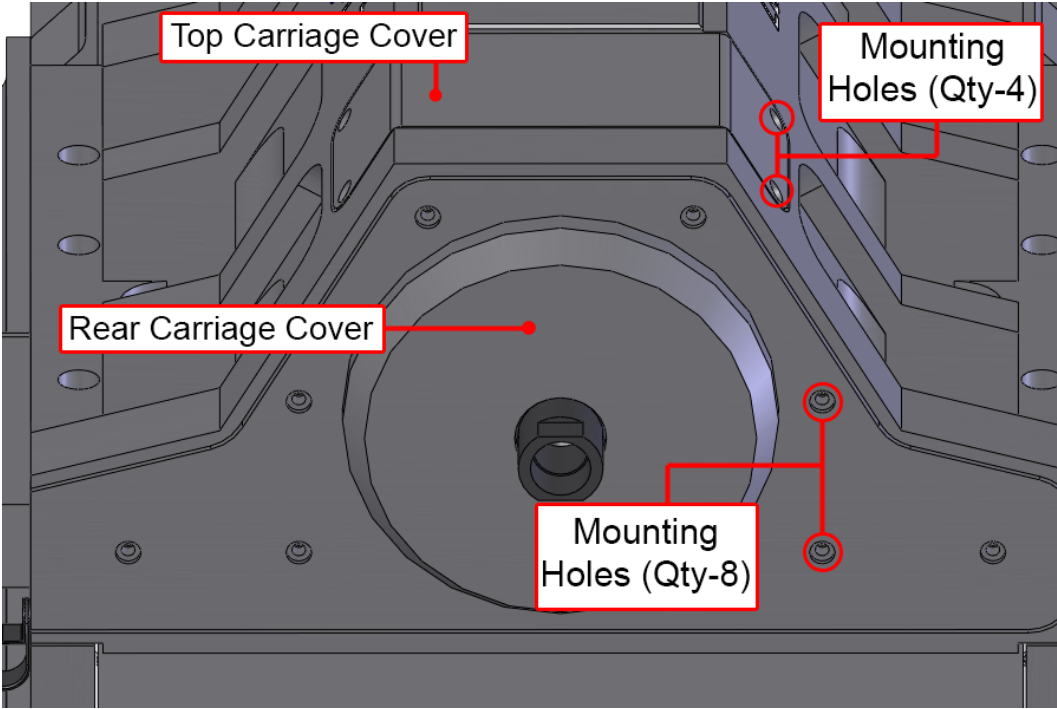

Figure 4-6: Carriage Cover Removal

Step 2: Remove the six seal assembly screws from the rear end of the rotary union (see [Figure 4-6](#)).

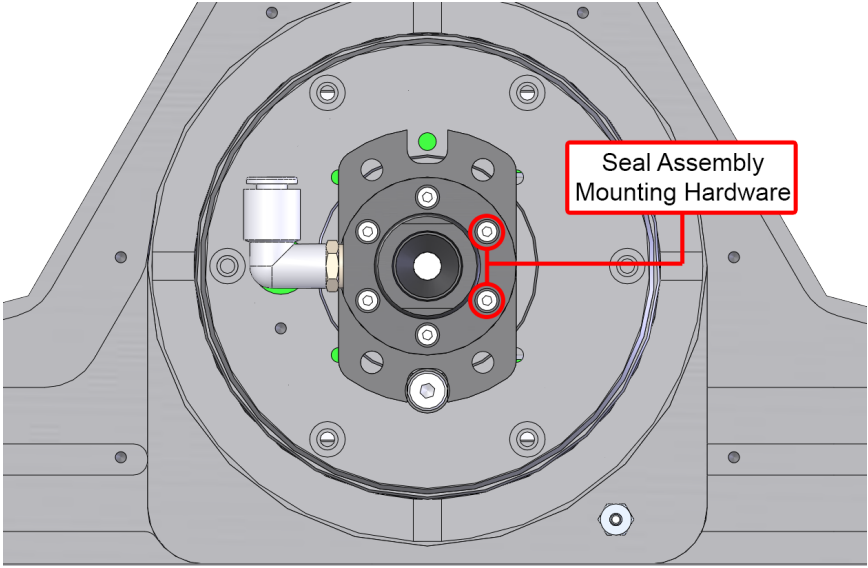
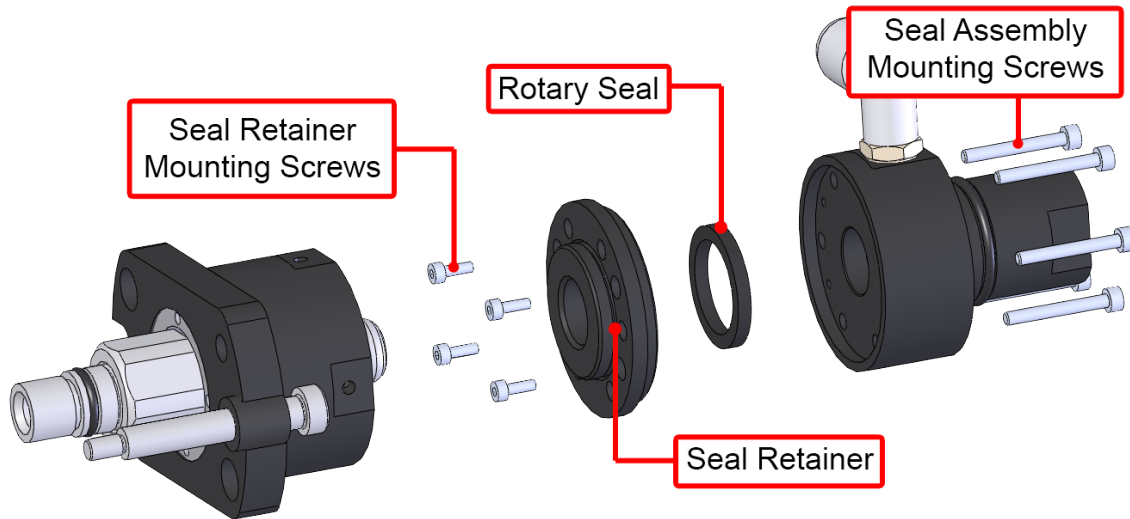

Figure 4-7: Seal Assembly Removal

Step 3: Carefully pull the seal assembly off of the stage. [4.3.3](#) shows an exploded view of the seal assembly.



Step 4: Remove the four seal retainer screws and remove the seal retainer. The rotary seal will now be exposed.

Step 5: Pry the rotary seal from its housing. Use care to not damage the sealing surfaces (see 4.3.3). Inspect the shaft and seal surface for scratches or nicks (see Figure 4-8). Small wear marks are normal. If the shaft and seal retainer sealing surface are undamaged, clean both the shaft and seal assembly surfaces with a lint-free cloth and isopropyl alcohol.

If the shaft or sealing surface is scratched (you can feel it with your fingernail), contact Aerotech customer service.

If advised to remove the rotary union, see Section 4.4. for instructions.

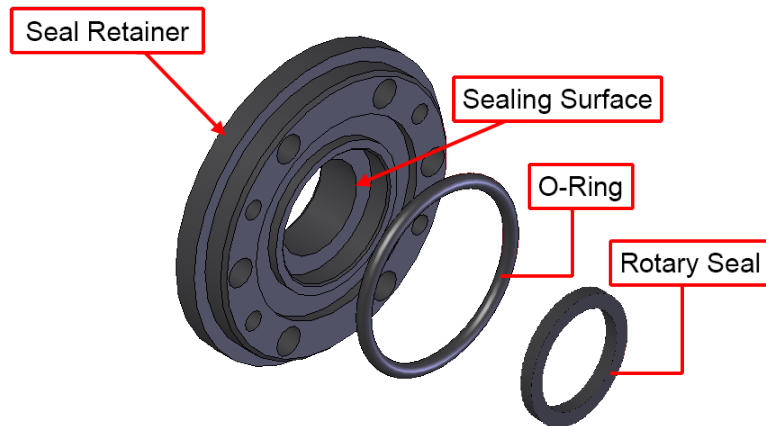

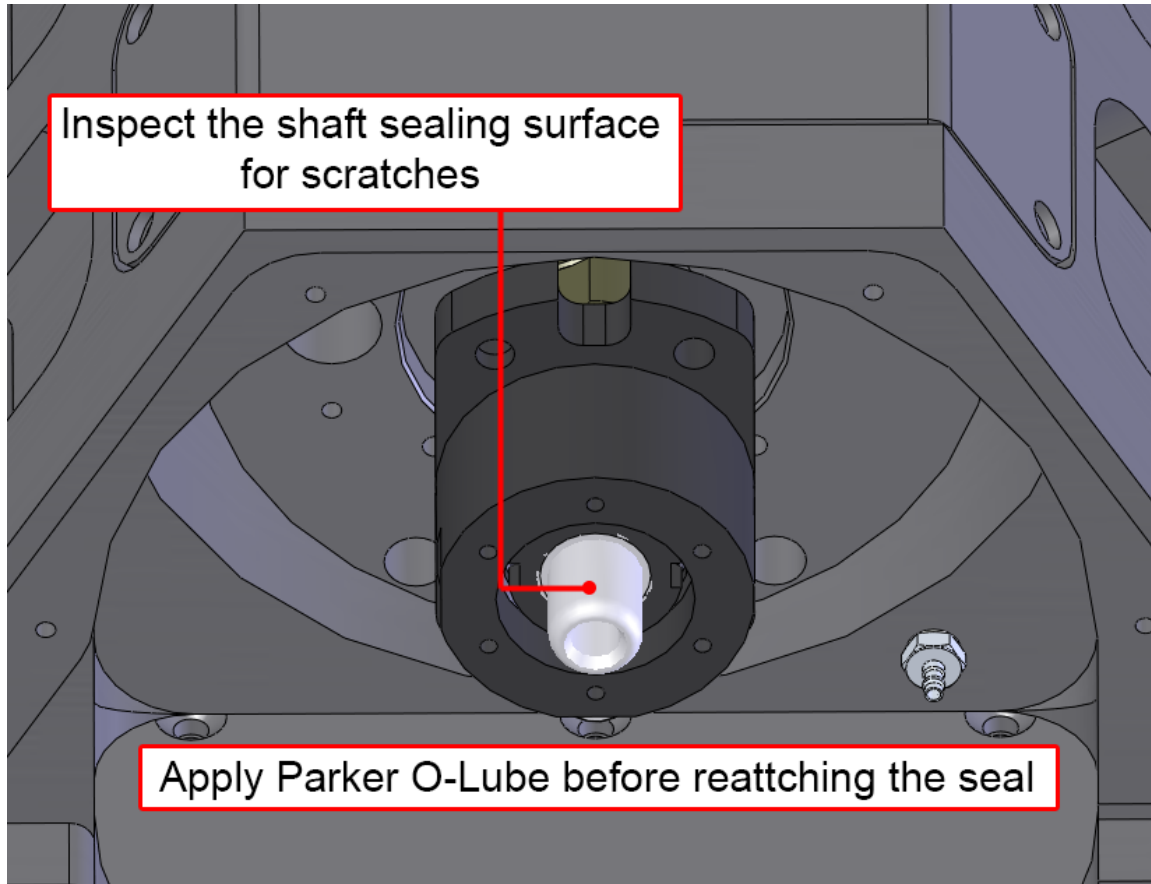

**Figure 4-8: Wet Cut Rotary Union Shaft Inspection**

- Step 6: Lubricate the new seal with a generous amount of Parker O-Lube and press it uniformly into its housing.
- Step 7: Reattach the seal retainer to the end cap and tighten all screws in a cross pattern.
- Step 8: Apply Parker O-Lube to the exposed end of the rotary union shaft as shown in [Figure 4-8](#).
- Step 9: Press the seal assembly back over the rotary union shaft. Use care so that damage does not occur to the newly installed seal.
- Step 10: Tighten the seal assembly screws and reattach the cover and fitting.
- Step 11: Restore power to the stage.

## 4.4. Wet Cut Rotary Union Removal

If the rotary union shaft becomes scratched or damaged, it will be necessary for the rotary union to be replaced in order to properly seal the system (refer to [Figure 4-9](#) for a view of the rotary union assembly).



**DANGER:** To minimize the possibility of bodily injury or death, disconnect all electrical power prior to performing any maintenance or making adjustments to the equipment.

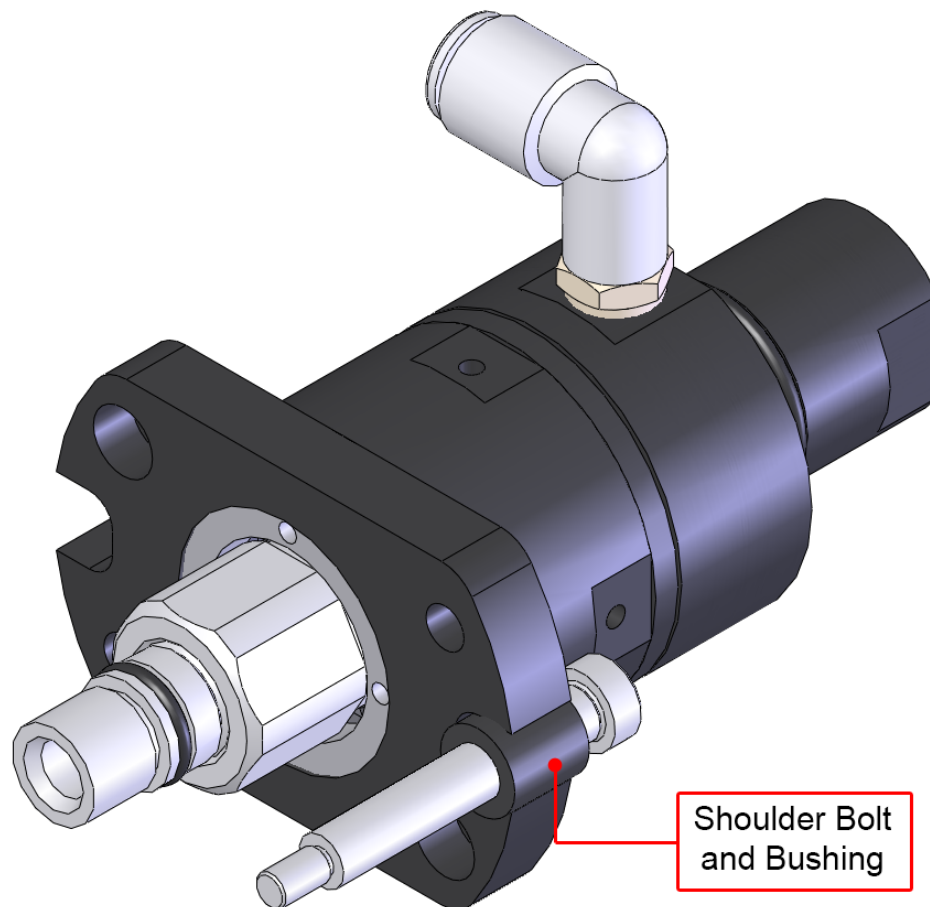

**Figure 4-9: Wet Cut Rotary Union**

- Step 1: Remove power the stage.
- Step 2: Remove the rear carriage cover and top carriage cover that is on the backside of the carriage. See [Section 4.3.3](#) for the removal procedure.
- Step 3: Remove the shoulder bolts and bushings (see [Figure 4-10](#)).

Step 4: Use two 19 mm wrenches (one on the rotary union shaft nut, the other on the LaserTurn<sup>®</sup>5-ASR shaft flats to unscrew the rotary union from the LaserTurn<sup>®</sup>5-ASR shaft (see [Figure 4-10](#)).

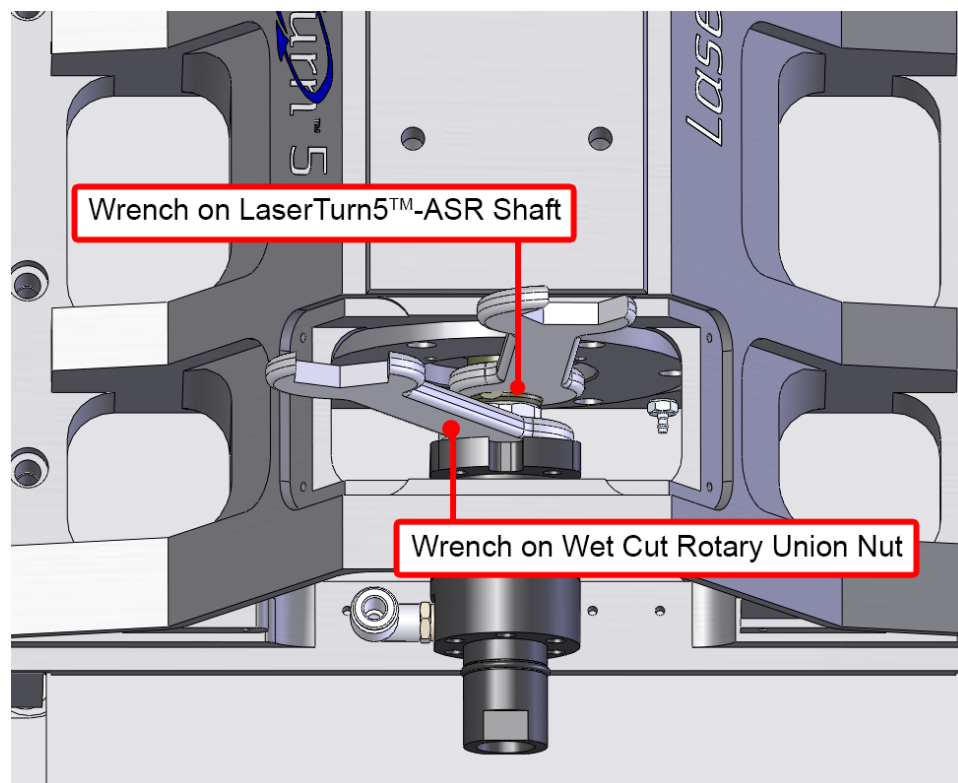

**Figure 4-10: Wet Cut Rotary Union Removal**

Step 5: Install a new rotary union assembly by attaching it to the rear of the LaserTurn<sup>®</sup>5-ASR shaft. Tighten to 13.5 N·m [10 ft-lbs]. Tighten the shoulder bolts and bushings.

Step 6: Reattach all covers.

Step 7: Restore power to the stage.

## 4.5. Linear Hardcover Removal

The covers have been designed so that they can be removed without having to remove endplates or customer fixtures on the tooling platforms.



**DANGER:** To minimize the possibility of bodily injury or death, disconnect all electrical power prior to performing any maintenance or making adjustments to the equipment.

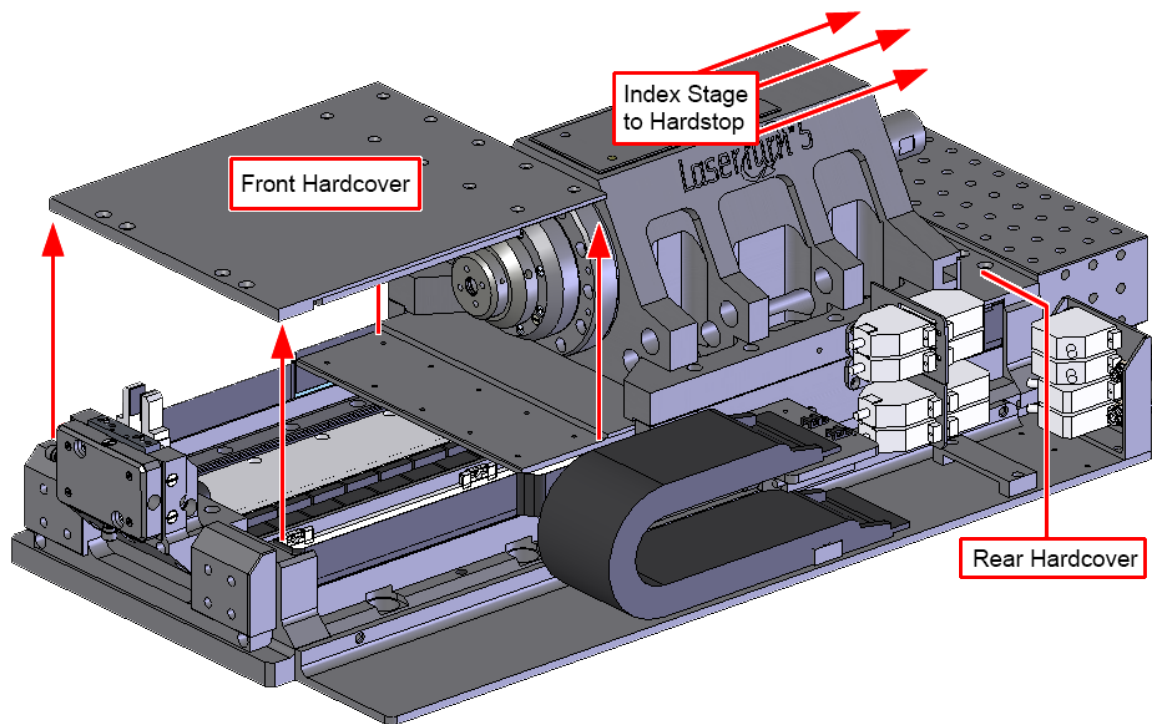

**Figure 4-11: Linear Hardcover Removal**

- Step 1: Remove power to stage.
- Step 2: Manually index the stage until the carriage is against the hardstop.
- Step 3: Remove [QTY-8] M4 flat head socket screws from the center of the cover.
- Step 4: Remove [QTY-4] M5 flat head socket screws from the cover near the front endplate.
- Step 5: Lift the hardcover straight up to remove it.
- Step 6: Repeat these steps to remove the rear hardcover.

## 4.6. Troubleshooting

| Symptom                     | Possible Cause and Solution                                                                                                                                                                                                                                                                                                                                                |
|-----------------------------|----------------------------------------------------------------------------------------------------------------------------------------------------------------------------------------------------------------------------------------------------------------------------------------------------------------------------------------------------------------------------|
| Stage will not move         | Controller trap or fault (refer to the Controller documentation).                                                                                                                                                                                                                                                                                                          |
| Stage moves uncontrollably  | <ul style="list-style-type: none"> <li>Encoder (sine and cosine) signal connections (refer to <a href="#">Chapter 3</a> and Controller documentation).</li> <li>Motor Connections (refer to <a href="#">Chapter 3</a> and the Controller documentation).</li> </ul>                                                                                                        |
| Stage oscillates or squeals | <ul style="list-style-type: none"> <li>Gains misadjusted (refer to the Controller documentation).</li> <li>Encoder signals (refer to the Controller documentation).</li> </ul>                                                                                                                                                                                             |
| Collet Chuck will not close | <ul style="list-style-type: none"> <li>Insufficient air pressure supplied to the stage. Make sure there are no blockages in the supply line and the pressure is high enough (refer to <a href="#">Section 2.4.</a>).</li> <li>Collet not threaded in all the way. Follow procedures in <a href="#">Section 2.8.</a> to ensure collet is installed properly</li> </ul>      |
| Collet Chuck will not open  | <ul style="list-style-type: none"> <li>Insufficient air pressure supplied to the stage. Make sure there are no blockages in the supply line and the pressure is high enough (refer to <a href="#">Section 2.4.</a>).</li> <li>The collet has not been lubricated properly or the lubrication needs to be replenished (refer to <a href="#">Section 4.2.1.</a>).</li> </ul> |



## Appendix A: Warranty and Field Service

Aerotech, Inc. warrants its products to be free from harmful defects caused by faulty materials or poor workmanship for a minimum period of one year from date of shipment from Aerotech. Aerotech's liability is limited to replacing, repairing or issuing credit, at its option, for any products that are returned by the original purchaser during the warranty period. Aerotech makes no warranty that its products are fit for the use or purpose to which they may be put by the buyer, whether or not such use or purpose has been disclosed to Aerotech in specifications or drawings previously or subsequently provided, or whether or not Aerotech's products are specifically designed and/or manufactured for buyer's use or purpose. Aerotech's liability on any claim for loss or damage arising out of the sale, resale, or use of any of its products shall in no event exceed the selling price of the unit.

THE EXPRESS WARRANTY SET FORTH HEREIN IS IN LIEU OF AND EXCLUDES ALL OTHER WARRANTIES, EXPRESSED OR IMPLIED, BY OPERATION OF LAW OR OTHERWISE. IN NO EVENT SHALL AEROTECH BE LIABLE FOR CONSEQUENTIAL OR SPECIAL DAMAGES.

### Return Products Procedure

Claims for shipment damage (evident or concealed) must be filed with the carrier by the buyer. Aerotech must be notified within thirty (30) days of shipment of incorrect material. No product may be returned, whether in warranty or out of warranty, without first obtaining approval from Aerotech. No credit will be given nor repairs made for products returned without such approval. A "Return Materials Authorization (RMA)" number must accompany any returned product(s). The RMA number may be obtained by calling an Aerotech service center or by submitting the appropriate request available on our website ([www.aerotech.com](http://www.aerotech.com)). Products must be returned, prepaid, to an Aerotech service center (no C.O.D. or Collect Freight accepted). The status of any product returned later than thirty (30) days after the issuance of a return authorization number will be subject to review.

Visit <https://www.aerotech.com/global-technical-support.aspx> for the location of your nearest Aerotech Service center.

### Returned Product Warranty Determination

After Aerotech's examination, warranty or out-of-warranty status will be determined. If upon Aerotech's examination a warranted defect exists, then the product(s) will be repaired at no charge and shipped, prepaid, back to the buyer. If the buyer desires an expedited method of return, the product(s) will be shipped collect. Warranty repairs do not extend the original warranty period.

**Fixed Fee Repairs** - Products having fixed-fee pricing will require a valid purchase order or credit card particulars before any service work can begin.

**All Other Repairs** - After Aerotech's evaluation, the buyer shall be notified of the repair cost. At such time the buyer must issue a valid purchase order to cover the cost of the repair and freight, or authorize the product(s) to be shipped back as is, at the buyer's expense. Failure to obtain a purchase order number or approval within thirty (30) days of notification will result in the product(s) being returned as is, at the buyer's expense.

Repair work is warranted for ninety (90) days from date of shipment. Replacement components are warranted for one year from date of shipment.

### Rush Service

At times, the buyer may desire to expedite a repair. Regardless of warranty or out-of-warranty status, the buyer must issue a valid purchase order to cover the added rush service cost. Rush service is subject to Aerotech's approval.

### On-site Warranty Repair

If an Aerotech product cannot be made functional by telephone assistance or by sending and having the customer install replacement parts, and cannot be returned to the Aerotech service center for repair, and if Aerotech determines the problem could be warranty-related, then the following policy applies:

Aerotech will provide an on-site Field Service Representative in a reasonable amount of time, provided that the customer issues a valid purchase order to Aerotech covering all transportation and subsistence costs. For warranty field repairs, the customer will not be charged for the cost of labor and material. If service is rendered at times other than normal work periods, then special rates apply.

If during the on-site repair it is determined the problem is not warranty related, then the terms and conditions stated in the following "On-Site Non-Warranty Repair" section apply.

### On-site Non-Warranty Repair

If any Aerotech product cannot be made functional by telephone assistance or purchased replacement parts, and cannot be returned to the Aerotech service center for repair, then the following field service policy applies:

Aerotech will provide an on-site Field Service Representative in a reasonable amount of time, provided that the customer issues a valid purchase order to Aerotech covering all transportation and subsistence costs and the prevailing labor cost, including travel time, necessary to complete the repair.

### Service Locations

<http://www.aerotech.com/contact-sales.aspx?mapState=showMap>

| USA, CANADA, MEXICO                                                                                | CHINA                                                                    | GERMANY                                                                                                    |
|----------------------------------------------------------------------------------------------------|--------------------------------------------------------------------------|------------------------------------------------------------------------------------------------------------|
| Aerotech, Inc.<br>Global Headquarters<br>Phone: +1-412-967-6440<br>Fax: +1-412-967-6870            | Aerotech China<br>Full-Service Subsidiary<br>Phone: +86 (21) 5508 6731   | Aerotech Germany<br>Full-Service Subsidiary<br>Phone: +49 (0)911 967 9370<br>Fax: +49 (0)911 967 93720     |
| JAPAN                                                                                              | TAIWAN                                                                   | UNITED KINGDOM                                                                                             |
| Aerotech Japan<br>Full-Service Subsidiary<br>Phone: +81 (0)50 5830 6814<br>Fax: +81 (0)43 306 3773 | Aerotech Taiwan<br>Full-Service Subsidiary<br>Phone: +886 (0)2 8751 6690 | Aerotech United Kingdom<br>Full-Service Subsidiary<br>Phone: +44 (0)1256 855055<br>Fax: +44 (0)1256 855649 |

Have your customer order number ready before calling.

## Appendix B: Revision History

| Revision | General Information                                                                                                                                                                                                                                                                                                                                                                                                                                                                                                                                                                                                                                                                                                                           |
|----------|-----------------------------------------------------------------------------------------------------------------------------------------------------------------------------------------------------------------------------------------------------------------------------------------------------------------------------------------------------------------------------------------------------------------------------------------------------------------------------------------------------------------------------------------------------------------------------------------------------------------------------------------------------------------------------------------------------------------------------------------------|
| 1.04.00  | <ul style="list-style-type: none"> <li>Updated safety and warning information</li> <li>General revision / product update</li> <li>Added/Updated Motor Wiring section: <a href="#">Section 3.2.</a></li> <li>Added/Updated Limits section: <a href="#">Section 3.4.</a></li> </ul>                                                                                                                                                                                                                                                                                                                                                                                                                                                             |
| 1.04.00  | <ul style="list-style-type: none"> <li>Added Declaration of Conformity: <a href="#">Section .</a></li> <li>Added Environmental Specifications: <a href="#">Section 1.1.</a></li> <li>Added safety information and warnings: <a href="#">Section .</a></li> <li>Added motor specifications: <a href="#">Section 1.3.</a></li> </ul>                                                                                                                                                                                                                                                                                                                                                                                                            |
| 1.03.00  | Corrected error in maximum aperture of ER25 collet: <a href="#">Section 1.3.</a>                                                                                                                                                                                                                                                                                                                                                                                                                                                                                                                                                                                                                                                              |
| 1.02.00  |                                                                                                                                                                                                                                                                                                                                                                                                                                                                                                                                                                                                                                                                                                                                               |
| 1.01.00  | <ul style="list-style-type: none"> <li>Added Wet Cut Fluid Requirements section: <a href="#">Section 2.5.</a></li> <li>Added Dimensions drawings: <a href="#">Section 2.2.</a></li> <li>Updated model numbering scheme: <a href="#">Section Chapter 1.</a></li> <li>Updated collet installation procedure: <a href="#">Section 2.8.1.</a></li> <li>Updated basic specifications: <a href="#">Section 1.3.</a></li> <li>Added pressure vessel limitations: <a href="#">Section 2.7.</a></li> <li>Changes for wet cut rotary union seal replacement: <a href="#">Section 4.3.3.</a></li> <li>Added wet cut rotary union removal section: <a href="#">Section 4.4.</a></li> <li>Changed page numbering from section based to absolute</li> </ul> |
| 1.00.00  | New manual                                                                                                                                                                                                                                                                                                                                                                                                                                                                                                                                                                                                                                                                                                                                    |

*This page intentionally left blank.*

## Index

|                          |          |                                    |            |       |
|--------------------------|----------|------------------------------------|------------|-------|
|                          |          |                                    | <b>D</b>   |       |
|                          | -        |                                    | Dimensions | 15    |
|                          |          |                                    | <b>E</b>   |       |
| -AG tooling option       |          |                                    |            |       |
| alignment                | 26       | EN 60204-1                         |            | 7     |
| -G tooling option        |          | EN ISO 12100                       |            | 7     |
| operation                | 25       | Encoder Specifications             |            | 36    |
|                          | <b>2</b> |                                    | <b>F</b>   |       |
| 2010                     | 7        | Flatness                           |            | 11    |
|                          | <b>A</b> |                                    | <b>G</b>   |       |
| Accuracy                 | 11       | Global Technical Support           |            | 2     |
| accuracy and temperature | 10       | gripper                            |            |       |
| air                      |          | operation                          |            | 25-26 |
| compressed               | 19       |                                    | <b>H</b>   |       |
| leakage                  | 19       | Hall-Effect Sensors Specifications |            | 36    |
| nitrogen                 | 19       | Humidity                           |            | 10    |
| requirements             | 19       |                                    | <b>I</b>   |       |
| air line                 | 20       | inspection schedule                |            | 43    |
| Air Pressure             | 11       | Inspection Schedule                |            | 43    |
| Altitude                 | 10       | isopropyl alcohol                  |            | 44    |
| Ambient Temperature      | 10       |                                    | <b>L</b>   |       |
|                          | <b>C</b> | label                              |            | 13    |
| cleaning                 | 44       | leakage (air)                      |            | 19    |
| collet/collet chuck      | 45       | Limit Switch Specifications        |            | 36    |
| linear                   | 46       | linear                             |            |       |
| mounting surface         | 17       | cleaning                           |            | 46    |
| solvents                 | 44       | lubrication                        |            | 46    |
| Cleaning                 | 44       | spar cover removal                 |            | 55    |
| Collet Type              | 11       | linear motion guide                |            |       |
| collet/collet chuck      |          | lubrication                        |            | 46    |
| cleaning                 | 45       | linear tooling platforms           |            | 20    |
| lubrication              | 45       | load capability                    |            |       |
| compressed air           | 19       | rotary union                       |            | 21    |

|                                      |       |                                            |    |
|--------------------------------------|-------|--------------------------------------------|----|
| lubrication                          | 44    | rotary union                               |    |
| collet/collet chuck                  | 45    | load capability                            | 21 |
| linear                               | 46    | pressure vessel length/weight limits       | 21 |
| Lubrication                          | 44    |                                            |    |
|                                      |       | <b>S</b>                                   |    |
| <b>M</b>                             |       | S-76-35-A                                  | 37 |
| maintenance                          | 43    | seal replacement                           | 47 |
| Maximum Speed                        | 11    | securing the stage to the mounting surface | 17 |
| Minimum System Air Pressure          | 11    | serial number                              | 13 |
| mounting                             |       | service schedule                           | 43 |
| linear platforms                     | 20    | shimming                                   | 17 |
| mounting surface                     |       | solvents                                   | 44 |
| cleaning                             | 17    | spar cover removal                         | 55 |
| securing stage                       | 17    | specifications                             |    |
|                                      |       | temperature                                | 10 |
| <b>N</b>                             |       | Specifications                             | 11 |
| nitrogen                             | 19    | stabilizing stage                          | 13 |
|                                      |       | <b>O</b>                                   |    |
| overview                             | 9     | stage                                      |    |
|                                      |       | distortion                                 | 17 |
| <b>P</b>                             |       | stabilizing                                | 13 |
| part number                          | 13    | Stage Mass                                 | 11 |
| performance (temperature)            | 10    | Straightness                               | 11 |
| piston seal replacement              | 47    | Support                                    | 2  |
| Pitch                                | 11    |                                            |    |
| pressure vessel length/weight limits | 21    | <b>T</b>                                   |    |
| Protection Rating                    | 10    | Technical Support                          | 2  |
|                                      |       | temperature and accuracy                   | 10 |
| <b>R</b>                             |       | Thermistor Specifications                  | 36 |
| Repeatability                        | 11    | Travel                                     | 11 |
| requirements                         |       |                                            |    |
| air                                  | 19    | <b>V</b>                                   |    |
| ringseal o-ring replacement          | 47    | Vibration                                  | 10 |
| rotary                               | 20    |                                            |    |
| Rotary Motor Specifications          | 37-39 | <b>W</b>                                   |    |
|                                      |       | Warranty and Field Service                 | 57 |
|                                      |       | Wet Cut Fluid Requirements                 | 19 |

---

|                                       |    |
|---------------------------------------|----|
| wet cut rotary union removal          | 53 |
| wet cut rotary union seal replacement | 49 |
| <b>Y</b>                              |    |
| Yaw                                   | 11 |

*This page intentionally left blank.*