

Ndrive ML Hardware Manual

Revision: 1.11.00

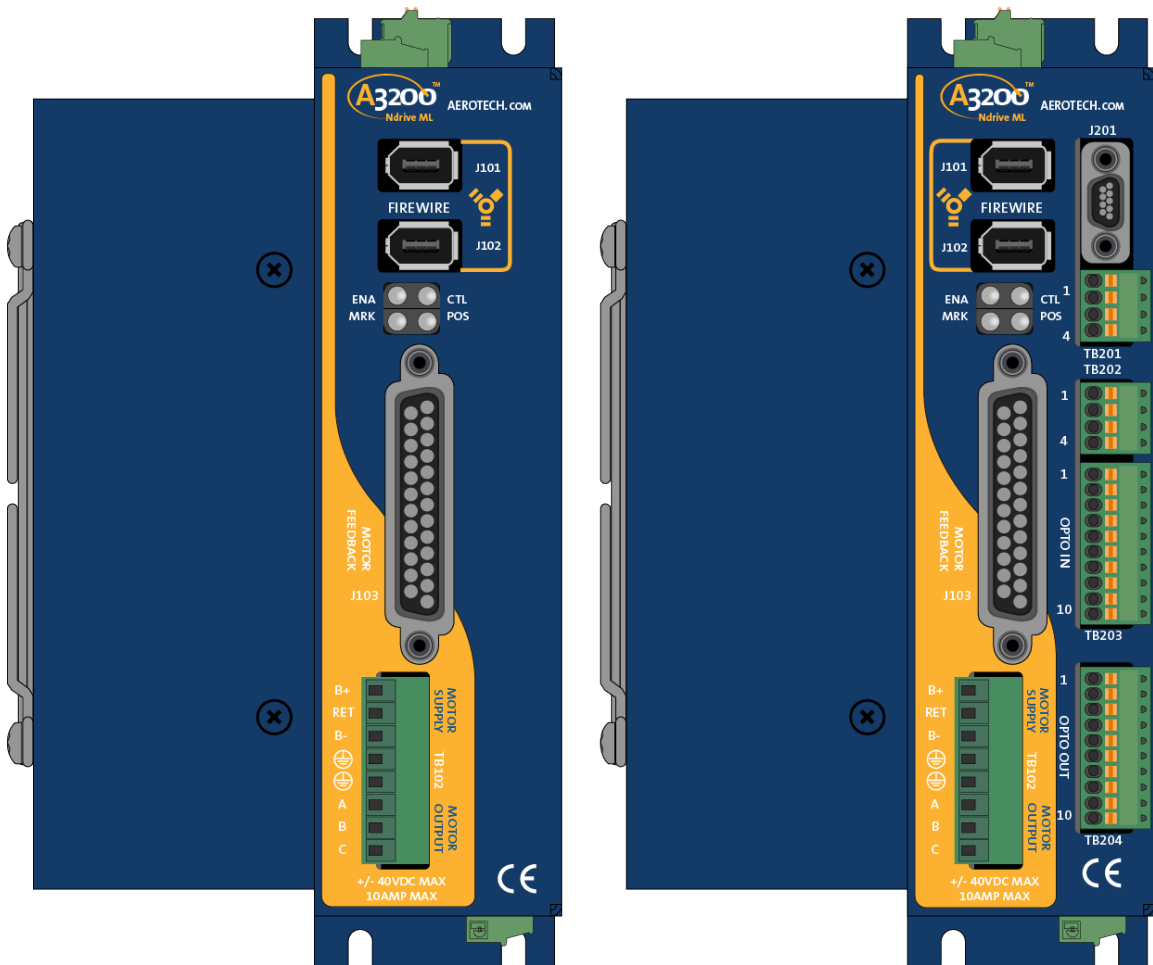

Global Technical Support

Go to www.aerotech.com/global-technical-support for information and support about your Aerotech, Inc. products. The website supplies software, product manuals, Help files, training schedules, and PC-to-PC remote technical support. If necessary, you can complete Product Return (RMA) forms and get information about repairs and spare or replacement parts. To get help immediately, contact a service office or your sales representative. Include your customer order number in your email or have it available before you call.

United States (World Headquarters)	
Email: Support@aerotech.com Phone: +1-412-967-6440 Fax: +1-412-967-6870	101 Zeta Drive Pittsburgh, PA 15238-2811 www.aerotech.com
United Kingdom	China
Email: Support@aerotech.com Phone: +44 (0)1256 855055 Fax: +44 (0)1256 855649	Email: Support@aerotech.com Phone: +86 (21) 5508 6731
Germany	Taiwan
Email: Support@aerotech.com Phone: +49 (0)911 967 9370 Fax: +49 (0)911 967 93720	Email: Support@aerotech.com Phone: +886 (0)2 8751 6690
France	
Email: Support@aerotech.com Phone: +33 2 37 21 87 65	

This manual contains proprietary information and may not be reproduced, disclosed, or used in whole or in part without the express written permission of Aerotech, Inc. Product names mentioned herein are used for identification purposes only and may be trademarks of their respective companies.

Copyright © 2008-2019, Aerotech, Inc., All rights reserved.

Aerotech Worldwide

United States ■ France ■ Germany ■ United Kingdom
China ■ Taiwan



Table of Contents

Ndrive ML Hardware Manual	1
Table of Contents	3
List of Figures	5
List of Tables	7
EU Declaration of Conformity	9
Agency Approvals	10
Safety Procedures and Warnings	11
Quick Installation Guide	13
Chapter 1: Introduction	15
1.1. Drive and Software Compatibility	19
1.2. Electrical Specifications	20
1.2.1. System Power Requirements	21
1.3. Mechanical Design	22
1.4. Environmental Specifications	23
Chapter 2: Installation and Configuration	25
2.1. Communication Channel Settings	25
2.2. Power Connections	26
2.2.1. Control Supply Connections (TB103)	27
2.2.2. Motor Supply Connections (TB102)	28
2.2.3. External Power Supply Options	29
2.3. Motor Output Connections	33
2.3.1. Brushless Motor Connections	34
2.3.1.1. Powered Motor Phasing	35
2.3.1.2. Unpowered Motor and Feedback Phasing	36
2.3.2. DC Brush Motor Connections	37
2.3.2.1. DC Brush Motor Phasing	38
2.3.3. Stepper Motor Connections	39
2.3.3.1. Stepper Motor Phasing	40
2.4. Motor Feedback Connections (J103)	41
2.4.1. Encoder Interface (J103)	42
2.4.1.1. RS-422 Line Driver Encoder (Standard)	43
2.4.1.2. Analog Encoder Interface	44
2.4.1.3. Encoder Phasing	46
2.4.2. Hall-Effect Interface (J103)	48
2.4.3. Thermistor Interface (J103)	49
2.4.4. Encoder Fault Interface (J103)	50
2.4.5. End Of Travel Limit Input Interface (J103)	51
2.4.5.1. End Of Travel Limit Phasing	53
2.4.6. Brake Output (J103)	54
2.4.7. Differential Analog Input 0 (J103)	55
2.5. Emergency Stop Sense Input (TB101)	56
2.5.1. Typical ESTOP Interface	57
2.6. FireWire Interface	58
2.7. PC Configuration and Operation Information	59
Chapter 3: -I/O Expansion Board	61
3.1. User Power (TB201)	62
3.2. Brake Relay Connector (TB201)	63
3.3. Analog I/O Connector (TB202)	65
3.3.1. Analog Output 1 (TB202)	66
3.3.2. Differential Analog Input 1 (TB202)	67

- 3.4. Opto In Connector (Digital Inputs) (TB203) 68
- 3.5. Opto Out Connector (Digital Outputs) (TB204) 71
- 3.6. Auxiliary Encoder Channel/PSO Output (J201) 74
 - 3.6.1. Position Synchronized Output (PSO)/Laser Firing (J201) 76
- Chapter 4: Standard Interconnection Cables 79**
 - 4.1. Joystick Interface 80
 - 4.2. Handwheel Interface 82
- Chapter 5: Maintenance 83**
 - 5.1. Preventative Maintenance 84
- Appendix A: Warranty and Field Service 85**
- Appendix B: Revision History 87**
- Index 89**

List of Figures

Figure 1-1:	Ndrive ML Networked Digital Drive	15
Figure 1-2:	Functional Diagram	18
Figure 1-3:	Dimensions	22
Figure 2-1:	Control Supply Connections	27
Figure 2-2:	Motor Bus Input Connections	28
Figure 2-3:	Control and Motor Power Wiring using a TM3 Transformer	30
Figure 2-4:	PS-ML Option (120 W, 24 VDC Output, with Brake)	31
Figure 2-5:	PS-ML Option (240 W, 24 VDC Output, with Brake)	31
Figure 2-6:	PS-ML Option (180 W, 40 VDC Output, with Brake)	32
Figure 2-7:	PS-ML Option (360 W, 40 VDC Output, with Brake)	32
Figure 2-8:	Brushless Motor Configuration	34
Figure 2-9:	Encoder and Hall Signal Diagnostics	35
Figure 2-10:	Motor Phasing Oscilloscope Example	36
Figure 2-11:	Brushless Motor Phasing Goal	36
Figure 2-12:	DC Brush Motor Configuration	37
Figure 2-13:	Clockwise Motor Rotation	38
Figure 2-14:	Stepper Motor Configuration	39
Figure 2-15:	Clockwise Motor Rotation	40
Figure 2-16:	Line Driver Encoder Interface (J103)	43
Figure 2-17:	Analog Encoder Phasing Reference Diagram	44
Figure 2-18:	Analog Encoder Interface (J103)	45
Figure 2-19:	Encoder Phasing Reference Diagram (Standard)	46
Figure 2-20:	Position Feedback in the Diagnostic Display	47
Figure 2-21:	Hall-Effect Inputs (J103)	48
Figure 2-22:	Thermistor Interface Input (J103)	49
Figure 2-23:	Encoder Fault Interface Input (J103)	50
Figure 2-24:	End of Travel Limit Input Connections	51
Figure 2-25:	End of Travel Limit Interface Input (J103)	52
Figure 2-26:	Limit Input Diagnostic Display	53
Figure 2-27:	Analog Input 0 (J103)	55
Figure 2-28:	ESTOP Sense Input (TB101)	56
Figure 2-29:	Typical Emergency Stop Circuit	57
Figure 3-1:	Ndrive ML with -IO Option Board	61
Figure 3-2:	Brake Connected to J103	64
Figure 3-3:	Brake Connected to TB201	64
Figure 3-4:	Analog Output 1 (TB202)	66
Figure 3-5:	Analog Input Typical Connection (TB202)	67
Figure 3-6:	Digital Opto-Isolated Inputs	69
Figure 3-7:	Digital Inputs Connected to a Current Sourcing Device	70
Figure 3-8:	Digital Inputs Connected to a Current Sinking Device	70
Figure 3-9:	Digital Opto-Isolated Outputs (-IO Board)	72
Figure 3-10:	Digital Outputs Connected in Current Sourcing Mode	73
Figure 3-11:	Digital Outputs Connected in Current Sinking Mode	73
Figure 3-12:	Auxiliary Encoder Channel (J201)	75
Figure 3-13:	PSO Interface	77
Figure 4-1:	Single Axis Joystick Interface	80
Figure 4-2:	Two Axis Joystick Interface	81
Figure 4-3:	Handwheel Interconnection (to Aux I/O)	82

This page intentionally left blank.

List of Tables

Table 1-1:	Feature Summary	16
Table 1-2:	Ordering Options	16
Table 1-3:	ML Power Supply Options	17
Table 1-4:	Accessories	17
Table 1-5:	Drive and Software Compatibility	19
Table 1-6:	Electrical Specifications	20
Table 1-7:	Physical Specifications	22
Table 2-1:	Device Number Switch Settings (S1)	25
Table 2-2:	Control Supply DC Input Wiring	27
Table 2-3:	Mating Connector Part Numbers for the Control Supply Connector	27
Table 2-4:	Motor Supply Input Wiring	28
Table 2-5:	Mating Connector Part Numbers for the Motor Supply Connector	28
Table 2-6:	External Power Supply Options	29
Table 2-7:	PS-ML AC Power Wiring Requirements	29
Table 2-8:	Motor Power Output Connections (TB102)	33
Table 2-9:	Mating Connector Part Numbers for the Motor Power Output Connector	33
Table 2-10:	Wire Colors for Aerotech Supplied Cables (Brushless)	34
Table 2-11:	Wire Colors for Aerotech Supplied Cables (DC Brush)	37
Table 2-12:	Wire Colors for Aerotech Supplied Cables (Stepper)	39
Table 2-13:	Motor Feedback Connector Pinout (J103)	41
Table 2-14:	Mating Connector Part Numbers for the Motor Feedback Connector (J103)	41
Table 2-15:	Encoder Interface Pins on the Motor Feedback Connector (J103)	42
Table 2-16:	Encoder Specifications	43
Table 2-17:	Analog Encoder Specifications	44
Table 2-18:	Hall-Effect Feedback Pins on the Motor Feedback Connector (J103)	48
Table 2-19:	Thermistor Pin on the Motor Feedback Connector (J103)	49
Table 2-20:	Encoder Fault Pin on the Motor Feedback Connector (J103)	50
Table 2-21:	End of Travel Limit Input Pins on the Motor Feedback Connector (J103)	51
Table 2-22:	Brake Output Pins on the Motor Feedback Connector (J103)	54
Table 2-23:	Differential Analog Input 0 Specifications	55
Table 2-24:	Differential Analog Input Pins on the Motor Feedback Connector (J103)	55
Table 2-25:	Electrical Noise Suppression Devices	56
Table 2-26:	Mating Connector Part Numbers for the ESTOP Connector (TB101)	56
Table 2-27:	Typical ESTOP Relay Ratings	57
Table 2-28:	FireWire Card Part Numbers	58
Table 2-29:	FireWire Repeaters (for cables exceeding 4.5 m (15 ft) specification)	58
Table 2-30:	FireWire Cables (copper and glass fiber)	58
Table 3-1:	User Common Connector Pins on the Brake Relay Connector (TB201)	62
Table 3-2:	Relay Specifications	63
Table 3-3:	Brake Relay Connector Pinout (TB201)	63
Table 3-4:	Mating Connector Part Numbers for the Brake Relay Connector (TB201)	63
Table 3-5:	Analog Output Connector Pinout (TB202)	65
Table 3-6:	Mating Connector Part Numbers for the Analog Output Connector (TB202)	65
Table 3-7:	Analog Output 1 Specifications (TB202)	66
Table 3-8:	Analog Output Pins on the Analog I/O Connector (TB202)	66
Table 3-9:	Differential Analog Input 1 Specifications	67
Table 3-10:	Differential Analog Input 1 Pins on the Analog I/O Connector (TB202)	67
Table 3-11:	Digital Input Specifications	68
Table 3-12:	Opto In Connector Pinout (TB203)	68
Table 3-13:	Mating Connector Part Numbers for the Opto In Connector (TB203)	68
Table 3-14:	Digital Output Specifications (TB204)	71

Table 3-15: Opto Out Connector Pinout (TB204)	71
Table 3-16: Mating Connector for the Opto Out Connector (TB204)	71
Table 3-17: Auxiliary Encoder Specifications	74
Table 3-18: Auxiliary Encoder Channel Pinout (J201)	74
Table 3-19: Mating Connector Part Numbers for the Auxiliary Encoder Connector (J201)	74
Table 3-20: PSO Specifications	76
Table 3-21: PSO Output Pin Assignment (J201)	76
Table 4-1: Standard Interconnection Cables	79
Table 4-2: Joystick Cable Part Numbers	81
Table 5-1: LED Description	83
Table 5-2: Preventative Maintenance	84

EU Declaration of Conformity

Manufacturer Aerotech, Inc.
Address 101 Zeta Drive
Pittsburgh, PA 15238-2811
USA
Product Ndrive ML
Model/Types All

This is to certify that the aforementioned product is in accordance with the applicable requirements of the following Directive(s):

2014/30/EU	Electromagnetic Compatibility Directive
2014/35/EU	Low Voltage Directive
2011/65/EU	RoHS 2 Directive

and has been designed to be in conformity with the applicable requirements of the following Standard(s) when installed and used in accordance with the manufacturer's supplied installation instructions.

EN 61800-3:2004	EMC Requirements for Power Drives
EN 61010-1:2010	Safety Requirements for Electrical Equipment

Authorized Representative: Simon Smith, European Director
Address: Aerotech Ltd
The Old Brick Kiln, Ramsdell, Tadley
Hampshire RG26 5PR
UK

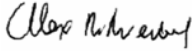
Name  / Alex Weibel
Position Engineer Verifying Compliance
Location Pittsburgh, PA
Date 11/26/2019



Agency Approvals

Aerotech, Inc. Model Ndrive ML Series Digital Drives have been tested and found to be in accordance to the following listed Agency Approvals:

Approval / Certification:	CUS NRTL
Approving Agency:	TUV SUD America Inc.
Certificate #:	U8 17 01 68995 023
Standards:	CAN/CSA-C22.2 No. 61010-1:2012; UL 61010-1:2012

Visit <https://www.tuev-sued.de/product-testing/certificates> to view Aerotech's TÜV SÜD certificates. Type the certificate number listed above in the search bar or type "Aerotech" for a list of all Aerotech certificates.

Safety Procedures and Warnings

This manual tells you how to carefully and correctly use and operate the Ndrive ML. Read all parts of this manual before you install or operate the Ndrive ML or before you do maintenance to your system. To prevent injury to you and damage to the equipment, obey the precautions in this manual. The precautions that follow apply when you see a Danger or Warning symbol in this manual. If you do not obey these precautions, injury to you or damage to the equipment can occur. If you do not understand the information in this manual, contact Aerotech Global Technical Support.

This product has been designed for light industrial manufacturing or laboratory environments. The protection provided by the equipment could be impaired if the product is used in a manner not specified by the manufacturer.

NOTE: Aerotech continually improves its product offerings; listed options may be superseded at any time. All drawings and illustrations are for reference only and were complete and accurate as of this manual's release. Refer to www.aerotech.com for the most up-to-date information.



DANGER: This product contains potentially lethal voltages. To reduce the possibility of electrical shock, bodily injury, or death the following precautions must be followed.

1. Disconnect electrical power before servicing equipment.
2. Disconnect electrical power before performing any wiring.
3. Access to the Ndrive ML and component parts must be restricted while connected to a power source.
4. To minimize the possibility of electrical shock and bodily injury, extreme care must be exercised when any electrical circuits are in use. Suitable precautions and protection must be provided to warn and prevent persons from making contact with live circuits.
5. Install the Ndrive ML inside a rack or enclosure.
6. Do not connect or disconnect any electrical components or connecting cables while connected to a power source.
7. All components must be properly grounded in accordance with local electrical safety requirements.
8. Operator safeguarding requirements must be addressed during final integration of the product.



DANGER: The Ndrive ML case temperature may exceed 70°C in some applications.



WARNING: To minimize the possibility of electrical shock, bodily injury or death the following precautions must be followed.

1. If the product is used in a manner not specified by the manufacturer, the protection provided by the product can be impaired and result in damage, shock, injury, or death.
2. Moving parts can cause crushing or shearing injuries. Access to all stage and motor parts must be restricted while connected to a power source.
3. Cables can pose a tripping hazard. Securely mount and position all system cables to avoid potential hazards.
4. Do not expose this product to environments or conditions outside of the listed specifications. Exceeding environmental or operating specifications can cause damage to the equipment.
5. Operators must be trained before operating this equipment.
6. All service and maintenance must be performed by qualified personnel.

Quick Installation Guide

This chapter describes the order in which connections and settings should typically be made to the Ndrive ML. If a custom interconnection drawing was created for your system (look for a line item on your Sales Order under the heading “Integration”), that drawing can be found on your installation device.

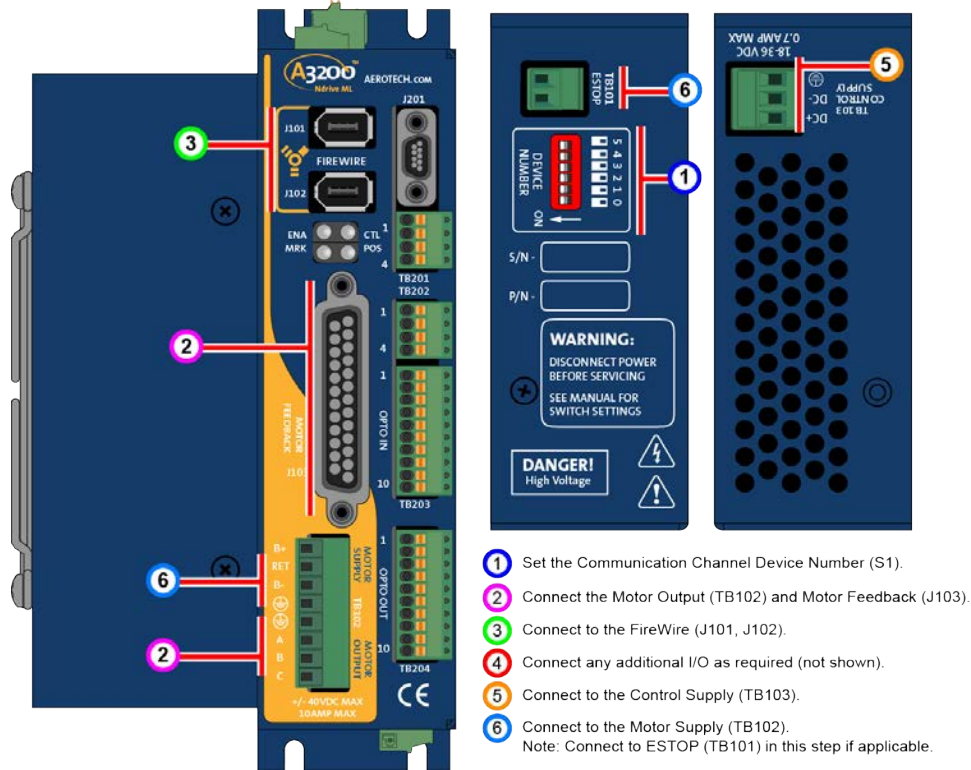

Figure 1: Quick Start Connections

Topic	Section
Device Number	Section 2.1. Communication Channel Settings
Motor Output	Section 2.3. Motor Output Connections
Motor Feedback	Section 2.4. Motor Feedback Connections (J103)
FireWire	Section 2.6. FireWire Interface
Control Supply	Section 2.2.1. Control Supply Connections (TB103)
Motor Supply	Section 2.2.2. Motor Supply Connections (TB102)
Additional I/O	User / Application dependent

This page intentionally left blank.

Chapter 1: Introduction

Aerotech's Ndrive ML (Ultra-Compact "Micro" Linear) network digital drive is a high performance linear amplifier designed to eliminate the nonlinearities common with PWM amplifiers. The drive provides deterministic behavior, auto-identification, and easy software setup. The Ndrive ML's high performance double precision floating point DSP controls the digital PID and current loops. All system configuration is done using software-settable parameters, including control loop gains and system safety functions.

The Ndrive ML is offered with an optional encoder interpolation feature (-MXH or -MXU), an auxiliary square wave encoder input for dual loop control, dedicated analog and digital I/O (expandable with the -IO option), and separate power connections for motor and control supply voltages.

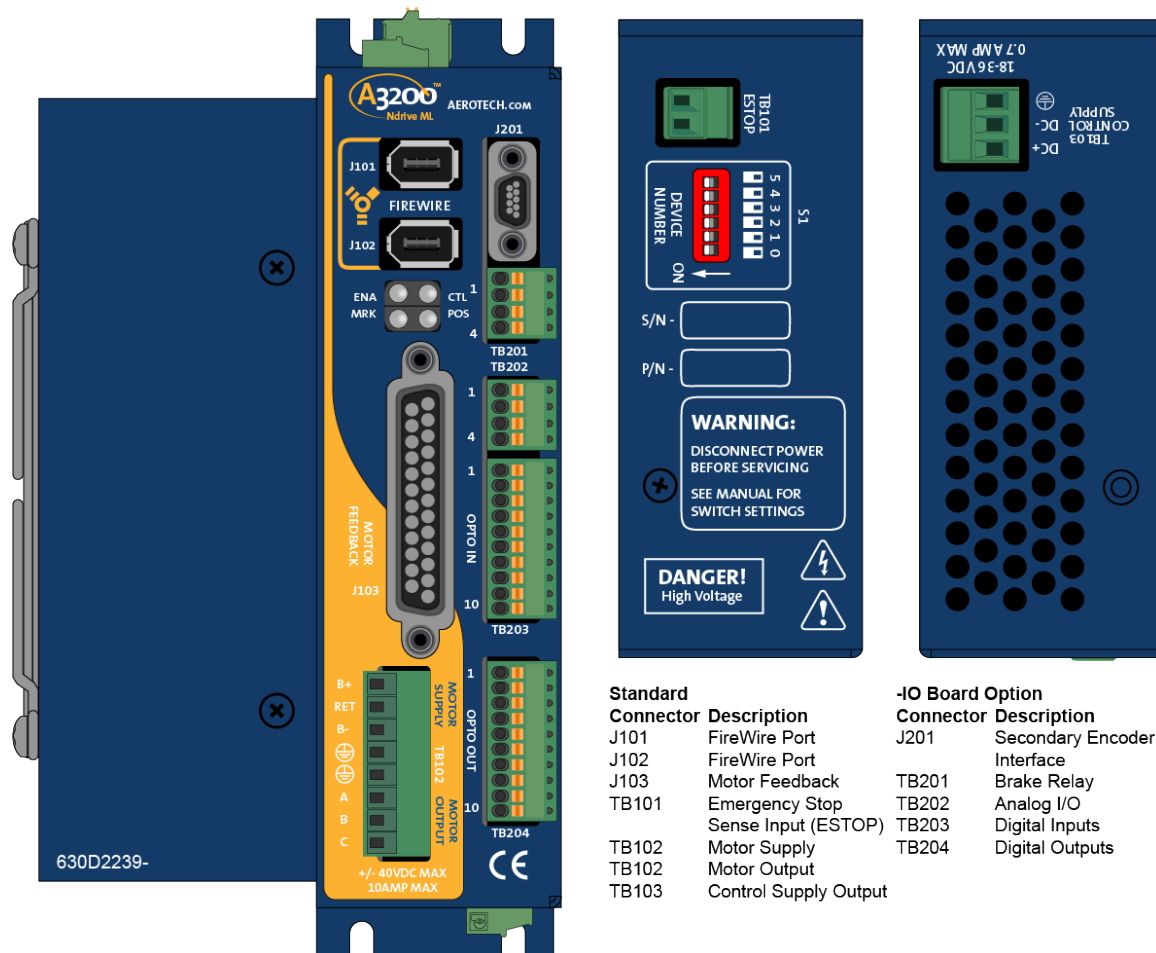

Figure 1-1: Ndrive ML Networked Digital Drive

Table 1-1: Feature Summary

Standard Features	
• 18 - 36 VDC control supply inputs (700 mA max)	Section 2.2.1.
• ± 40 VDC motor supply inputs (10 A max)	Section 2.2.2.
• Primary quadrature encoder input channel	Section 2.4.1.
• Dedicated Home and Limit inputs	Section 2.4.5.
• Dedicated 5-24 V Emergency Stop sense input	Section 2.5.
• One 16-bit analog differential input (± 10 VDC)	Section 2.4.7.
• Single-axis PSO capability (I/O board required)	Section 3.6.1.

Table 1-2: Ordering Options

Options	
Power Stage Options (Section 1.2.)	
10-40	10 A peak; 5 A continuous, ± 40 VDC input
I/O (Chapter 3) and Feedback (Section 2.4.1.2.) Options	
-IO	Expansion board with 8 digital inputs (opto-isolated); 8 digital outputs (opto-isolated); one 12-bit analog input; one 16-bit analog output
-MXU	Programmable encoder multiplier up to x1024 (x4096 after quadrature); no real-time output
-MXH	Programmable encoder multiplier up to x4096 (x65536 after quadrature) with real-time output
PSO Options (Section 3.6.1.)	
-DUALPSO	Two-axis PSO firing
Power Supply Option (Section 2.2.3.)	
-PS-ML	DC power supply for one or two axes; mounted to DIN rail

Table 1-3: ML Power Supply Options

Options	
Power Supply Options	
-DR-120-24-A	120 W; ± 24 VDC; 100-120 VAC supply; peak current = 5 A
-DR-120-24-B	120 W; ± 24 VDC; 200-240 VAC supply; peak current = 5 A
-DR-240-24-A	240 W; ± 24 VDC; 100-120 VAC supply; peak current = 10 A
-DR-240-24-B	240 W; ± 24 VDC; 200-240 VAC supply; peak current = 10 A
-DR-120-40-A	120 W; ± 40 VDC; 100-120 VAC supply; peak current = 2.5 A
-DR-120-40-B	120 W; ± 40 VDC; 200-240 VAC supply; peak current = 2.5 A
-DR-240-40-A	240 W; ± 40 VDC; 100-120 VAC supply; peak current = 5 A
-DR-240-40-B	240 W; ± 40 VDC; 200-240 VAC supply; peak current = 5 A
Note: Aerotech will set the peak current parameters in the controller to try to prevent the power supply from shutting off due to overcurrent condition.	
Axes	
-1AX	1 axis of wiring
-2AX	2 axes of wiring
Brake	
-BRAKE-1	Axis 1 brake
-BRAKE-2	Axis 2 brake

Table 1-4: Accessories

Accessories	
J1	Industrial Joystick (NEMA12 (IP54) rated); refer to Section 4.1 .
PS24-1	24 VDC, 1 A power supply for optional brake/relay output
BRAKE24-2	24 VDC, 2 A power supply for optional brake
Cables	
Interconnection	A complete list of Aerotech cables can be found on the website at http://www.aerotechmotioncontrol.com/manuals/index.aspx
Joystick/Handwheel	Refer to Section 4.1 . or Section 4.2 .
FireWire	Refer to Section 2.6 .

The following block diagram shows a connection summary. For detailed connection information, refer to Chapter 2 and Chapter 3.

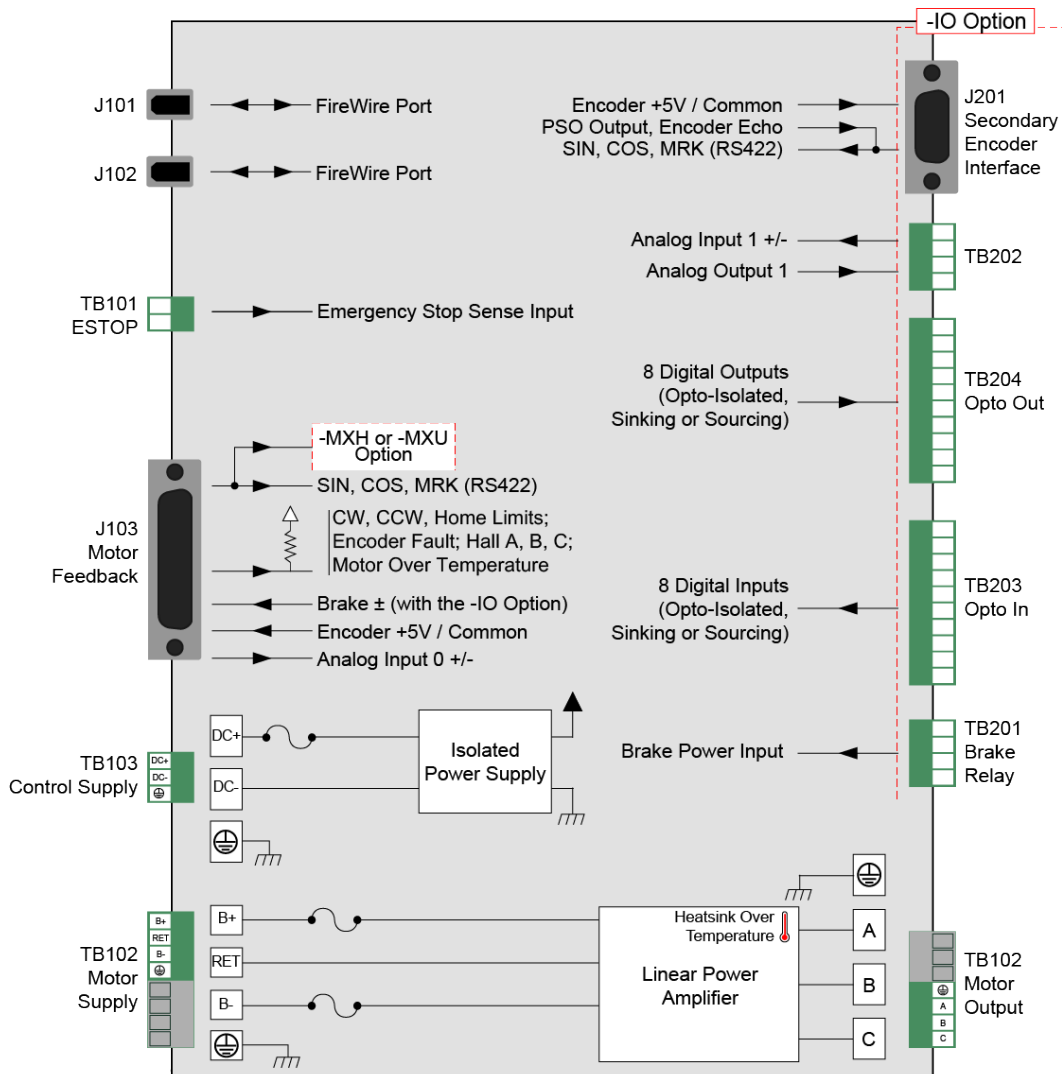

Figure 1-2: Functional Diagram

1.1. Drive and Software Compatibility

The following table lists the available drives and which version of the software first supported the drive. Drives that list a specific version number in the **Last Software Version** column will not be supported after the listed version.

Table 1-5: Drive and Software Compatibility

Drive Type	Firmware Revision	First Software Version	Last Software Version
Ndrive ML	-	3.00	Current

1.2. Electrical Specifications

The safe operating range is load dependent.

Table 1-6: Electrical Specifications

Description		ML 10
Motor Supply	Input Voltage	±40 VDC (max)
	Input Current (continuous)	5 A
	Input Current (peak)	10 A
	Input Current	Refer to Section 1.2.1. System Power Requirements
Control Supply	Input Voltage	24 VDC typical (18-36 VDC)
	Input Current	700 mA (max)
Output Voltage ⁽¹⁾		±38V @ 10 A
Peak Output Current ⁽²⁾		10
Continuous Output Current ⁽²⁾		5
Power Amplifier Bandwidth		2500 Hz maximum (software selectable)
Minimum Load Resistance		0.5 Ω
Output Impedance		0.2 Ω (each phase)
User Power Supply Output		5 VDC (@ 500 mA)
Modes of Operation		Brushless; Brush; Stepper
Protective Features		Peak current limit; Over temperature; RMS current limit; Dynamic power dissipation limit
Isolation		Isolation between control and power stages.
1. Load Dependent		
2. Peak and continuous output current is load dependent (the amplifier will limit its output current based on motor speed and motor resistance).		

1.2.1. System Power Requirements

The following equations can be used to determine total system power requirements. The actual power required from the mains supply will be the combination of actual motor power (work), motor resistance losses, and efficiency losses in the power electronics or power transformer. An EfficiencyFactor of approximately 50% should be used in the following equations.

Linear Motor

$$P_{diss}[W] = MotorCurrentPeak[A] * TotalBusVoltage[V] * 3 / 2$$

$$P_{in} = \text{SUM} (P_{diss}) / EfficiencyFactor$$

1.3. Mechanical Design

Install the unit into a construction compliant for unlimited circuits enclosure. Each unit should be separated from other drives and surrounded by 25 mm (1") of free air space. A space of 100 mm (4") should be allowed along the front of the unit for cable connections.

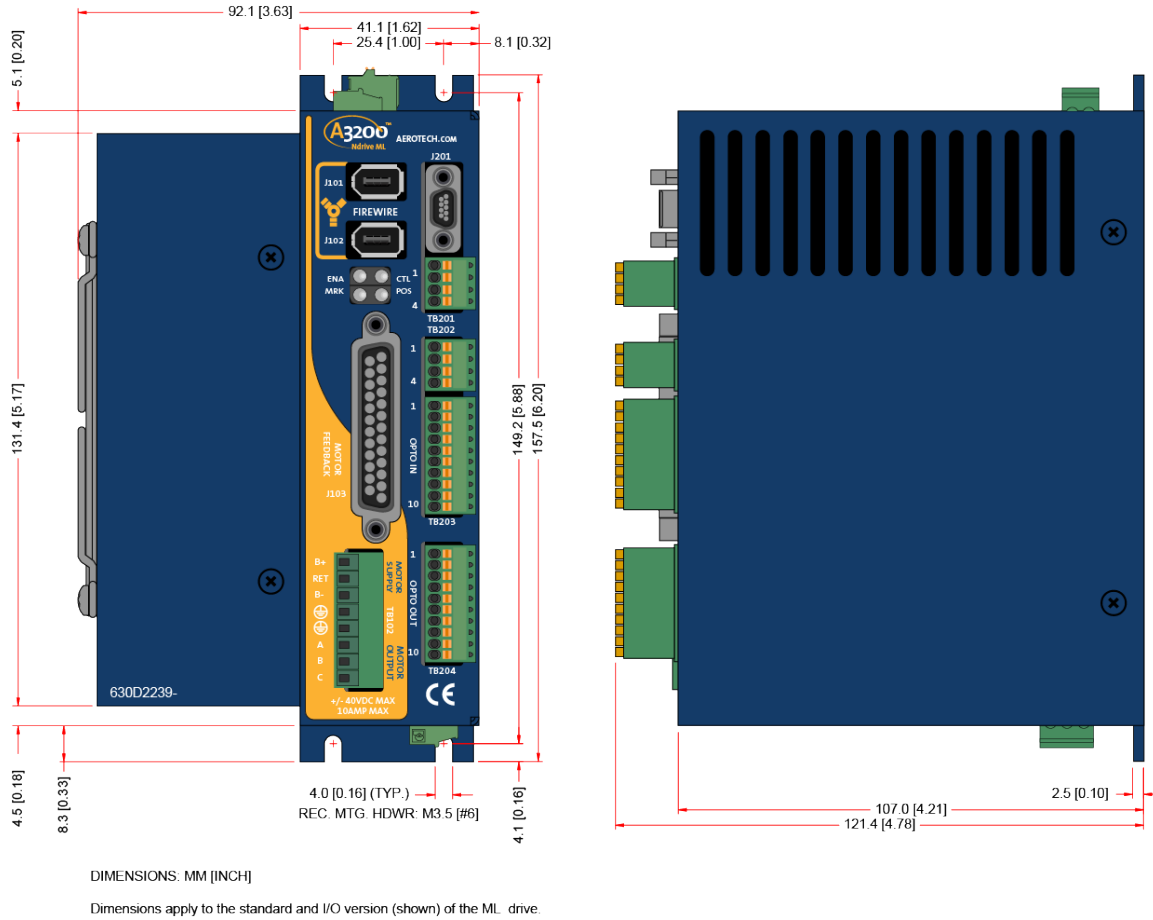

Figure 1-3: Dimensions

Table 1-7: Physical Specifications

Model	Weight
Standard	.91 kg (2 lb)
w/ -IO option	.99 kg (2.2 lb)
w/ -MXH option	.99 kg (2.2 lb)

1.4. Environmental Specifications

The environmental specifications for the Ndrive ML are listed below.

Ambient Temperature	Operating: 0° to 50°C (32° to 122° F)
	Storage: -30° to 85°C (-22° to 185° F)
Humidity	Maximum relative humidity is 80% for temperatures up to 31°C. Decreasing linearly to 50% relative humidity at 40°C. Non condensing.
Altitude	Up to 2000 meters.
Pollution	Pollution degree 2 (normally only non-conductive pollution).
Use	Indoor use only.

This page intentionally left blank.

Chapter 2: Installation and Configuration

2.1. Communication Channel Settings

Use the Device Number switches to assign a communication channel number to the Ndrive ML. If you are using multiple drives, each drive must be assigned a unique communication channel. Multiple drives are typically configured using sequential communication channels.

NOTE: The drive assigned to the first communication channel number (all switches set to ON) will be configured by the Axis 1 parameters defined in the software. The drive assigned to the second communication channel will be configured by the Axis 2 parameters, etc.

Table 2-1: Device Number Switch Settings (S1)

Device #	Switch Settings (Off is indicated by "-")						Switch Location
	5	4	3	2	1	0	
1	ON	ON	ON	ON	ON	ON	
2	ON	ON	ON	ON	ON	-	
3	ON	ON	ON	ON	-	ON	
4	ON	ON	ON	ON	-	-	
5	ON	ON	ON	-	ON	ON	
6	ON	ON	ON	-	ON	-	
7	ON	ON	ON	-	-	ON	
8	ON	ON	ON	-	-	-	
9	ON	ON	-	ON	ON	ON	
10	ON	ON	-	ON	ON	-	
11	ON	ON	-	ON	-	ON	
12	ON	ON	-	ON	-	-	
13	ON	ON	-	-	ON	ON	
14	ON	ON	-	-	ON	-	
15	ON	ON	-	-	-	ON	
16	ON	ON	-	-	-	-	
17	ON	-	ON	ON	ON	ON	
18	ON	-	ON	ON	ON	-	
19	ON	-	ON	ON	-	ON	
20	ON	-	ON	ON	-	-	
21	ON	-	ON	-	ON	ON	
22	ON	-	ON	-	ON	-	
23	ON	-	ON	-	-	ON	
24	ON	-	ON	-	-	-	
25	ON	-	-	ON	ON	ON	
26	ON	-	-	ON	ON	-	
27	ON	-	-	ON	-	ON	
28	ON	-	-	ON	-	-	
29	ON	-	-	-	ON	ON	
30	ON	-	-	-	ON	-	
31	ON	-	-	-	-	ON	
32	ON	-	-	-	-	-	

2.2. Power Connections

The Ndrive ML has two DC input connectors; one for control power and a second for motor power. For a complete list of electrical specifications, refer to [Section 1.2](#).

NOTE: The machine integrator, OEM or end user is responsible for meeting the final protective grounding requirements of the system.



WARNING: All service and maintenance must be performed by qualified personnel.



DANGER: Hazardous Voltages are present on Ndrive ML systems.



DANGER: Ndrive ML and PS-ML systems must be installed inside a rack or enclosure to restrict access while energized.



DANGER: To minimize the possibility of bodily injury or death, disconnect all electrical power prior to performing any maintenance or making adjustments to the equipment.

2.2.1. Control Supply Connections (TB103)

NOTE: This product requires two power supply connections. The Motor Supply and Control Supply must both be connected for proper operation.

The control power supply input allows the Ndrive ML to maintain communications if the motor power is removed, such as in an Emergency Stop condition. The DC+ input is internally fused.

A small ferrite filter may be required to minimize radiated emissions. This should be located close to the Ndrive ML.

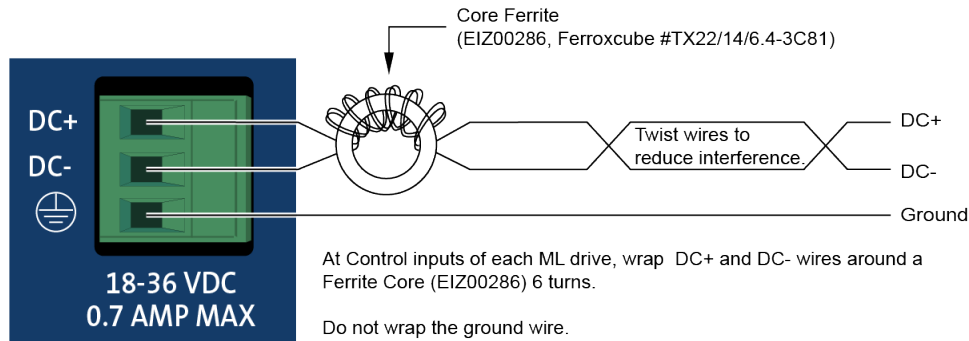

Figure 2-1: Control Supply Connections

Table 2-2: Control Supply DC Input Wiring

Pin	Description	Recommended Wire Size ^(1,2)
DC+	24 VDC (18-36 VDC) Control Power Input (700 mA max)	0.5 mm ² (#20 AWG)
DC-	Control Power Common Input ⁽¹⁾	0.5 mm ² (#20 AWG)
⊕	Protective Ground (Required for Safety)	0.5 mm ² (#20 AWG)

(1) For an isolated DC supply, connect DC- to protective ground at the supply.

(2) Refer to local electrical safety requirements to correctly size external system wires.

Table 2-3: Mating Connector Part Numbers for the Control Supply Connector

Description	Aerotech P/N	Phoenix P/N	Tightening Torque (Nm)	Wire Size: AWG [mm ²]
3-Pin Terminal Block	ECK01387	1803581	0.22 - 0.25	14 - 30 [2.0 - 0.0516]

2.2.2. Motor Supply Connections (TB102)

NOTE: This product requires two power supply connections. The Motor Supply and Control Supply must both be connected for proper operation.

Motor power is applied to the Ndrive ML Motor Supply connector (refer to [Figure 2-2](#) for locations).



WARNING: Do not operate the Ndrive ML without the safety ground connection in place.

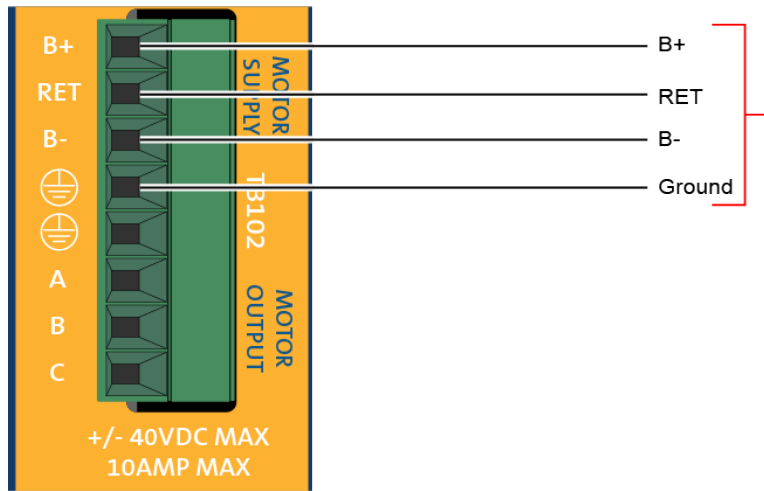

Figure 2-2: Motor Bus Input Connections

Table 2-4: Motor Supply Input Wiring

Pin	Description	Recommended Wire Size ⁽¹⁾
B+	+DC Motor Supply Input (+40 VDC max, 10 A)	0.5 mm ² (#20 AWG)
RET	DC Motor Supply Return	0.5 mm ² (#20 AWG)
B-	-DC Motor Supply Input (-40 VDC max, 10 A)	0.5 mm ² (#20 AWG)
⊕	Protective Ground (Required for Safety)	0.5 mm ² (#20 AWG)

(1) Refer to local electrical safety requirements to correctly size external system wires.

Table 2-5: Mating Connector Part Numbers for the Motor Supply Connector

Description	Aerotech P/N	Phoenix P/N	Tightening Torque (Nm)	Wire Size: mm ² [AWG]
8-Pin Terminal Block	ECK01424	1803633	0.22 - 0.25	2.0 - 0.516 [14-30]

2.2.3. External Power Supply Options

Two VDC power options are available to power up to four MLs.

Table 2-6: External Power Supply Options

	Description
TM3 ⁽¹⁾	Power up to 4 drives, providing 300 watts of power (refer to Figure 2-3).
PS-ML	Din-rail mounted DC power supply for up to 2 axes. The din-rail mounting clip requires 6-32 x 5/16 flat head screws to attach the ML to the din-rail clip. Refer to Figure 2-4 through Figure 2-7 . Click on an image to expand and open it as a new pdf.
1. Refer to the TM3 Users Manual, EDO117, for more information.	

Examples of wiring drawings for a typical PS-ML systems that show the power inputs, as well as wiring for the optional fail-safe brake, are shown in the figures below. The AC operating voltage of the PS-ML system can be configured for different operating voltages. Purchased PS-ML systems are configured at the factory according to the users order request. System wiring and operating voltage information can be found on the System Wiring Drawing that is provided with the unit. The machine integrator, OEM, or end user is responsible for providing two fused or circuit breaker protected AC power connections and a Protective Ground connection to the system (see the table below for specifications).

Table 2-7: PS-ML AC Power Wiring Requirements

Connection	Description	Wire Size (minimum)
AC1	AC Power	1.3 mm ² (#16 AWG) 300 V wire
AC2	AC Power	1.3 mm ² (#16 AWG) 300 V wire
GND	Protective Ground (required for safety)	1.3 mm ² (#16 AWG) 300 V wire
User must provide 10 A, 250 VAC fuse(s) or circuit breaker(s) to protect AC inputs		

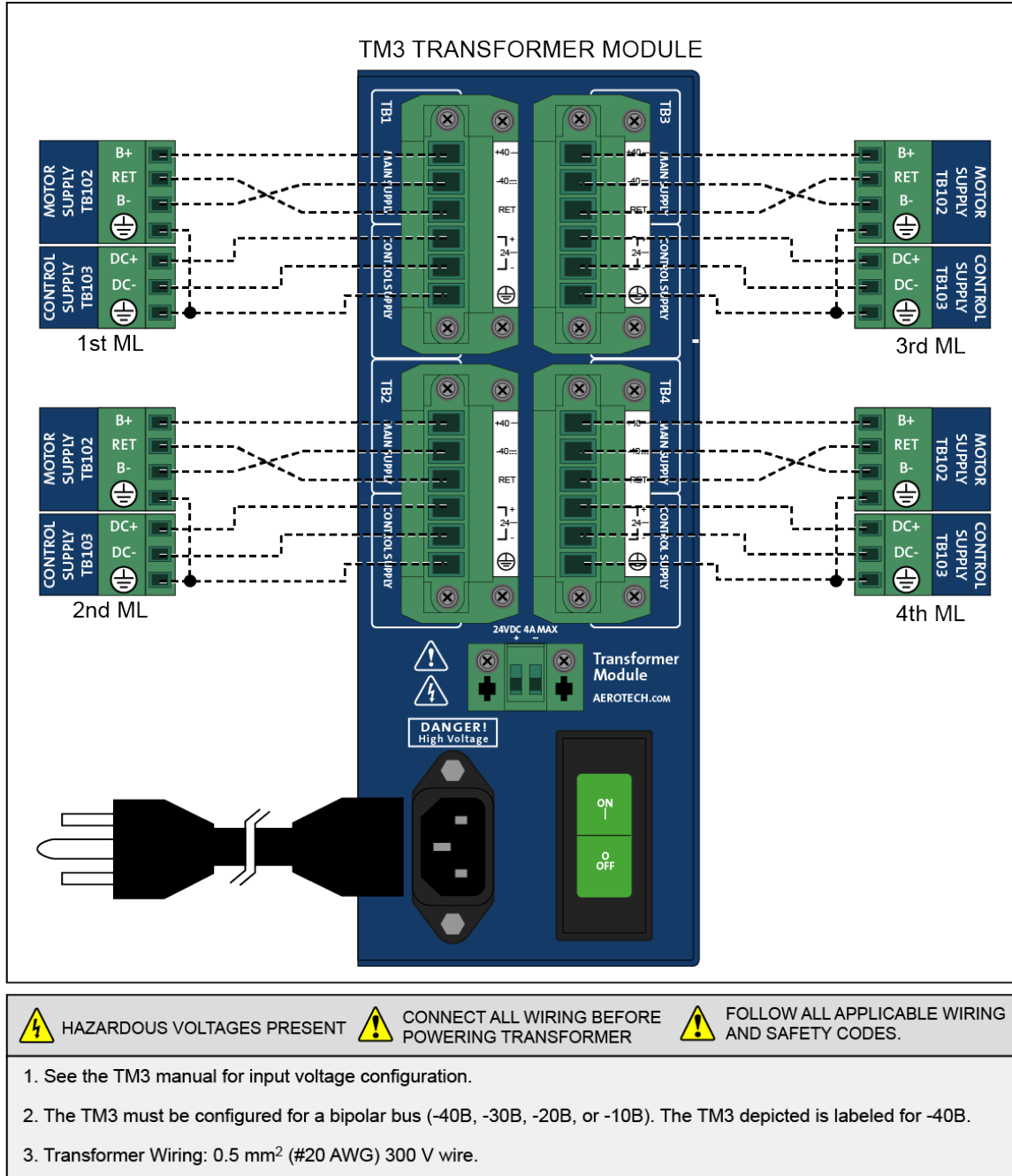

Figure 2-3: Control and Motor Power Wiring using a TM3 Transformer

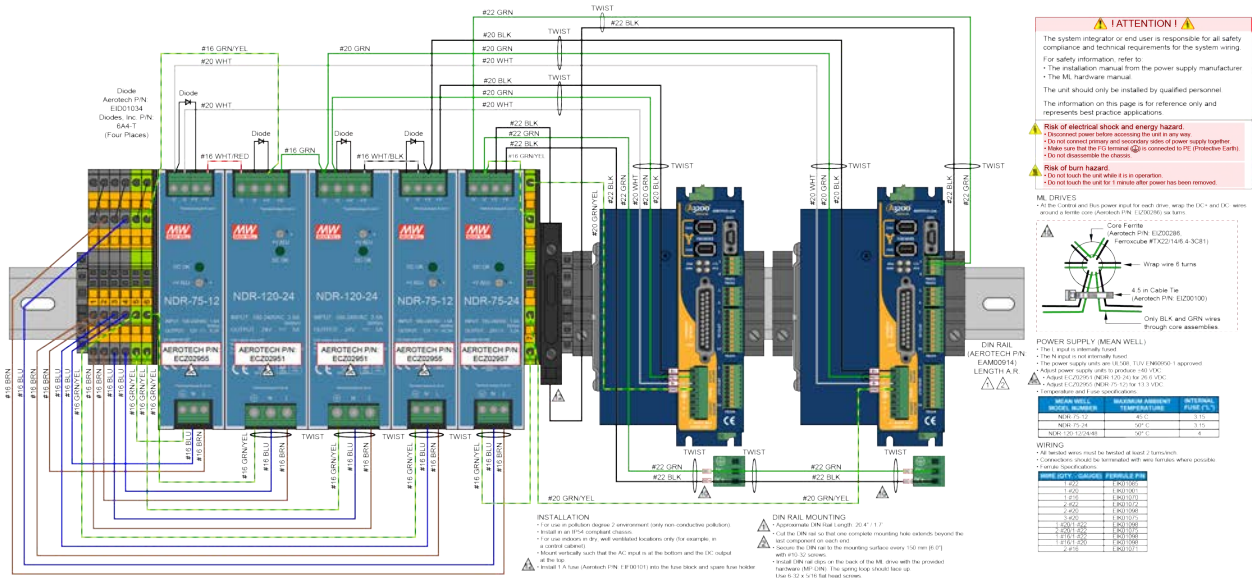

Figure 2-6: PS-ML Option (180 W, 40 VDC Output, with Brake)

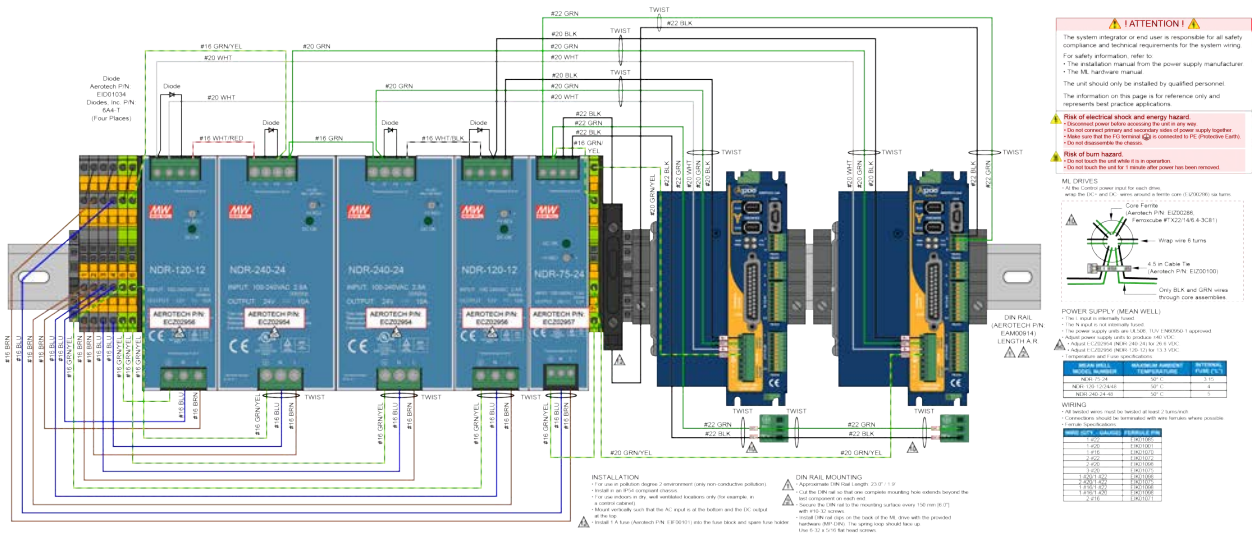

Figure 2-7: PS-ML Option (360 W, 40 VDC Output, with Brake)

2.3. Motor Output Connections

The Ndrive ML is capable of controlling three motor types:

- Brushless (see [Section 2.3.1.](#))
- DC Brush (see [Section 2.3.2.](#))
- Stepper (see [Section 2.3.3.](#))

For a complete list of electrical specifications, refer to [Section 1.2.](#)

Table 2-8: Motor Power Output Connections (TB102)

Pin	Description	Recommended Wire Size
ØA	Phase A Motor Lead	0.5 mm ² (#20 AWG)
ØB	Phase B Motor Lead	0.5 mm ² (#20 AWG)
ØC	Phase C Motor Lead	0.5 mm ² (#20 AWG)
	Earth Ground to Motor (required for safety)	0.5 mm ² (#20 AWG)

Table 2-9: Mating Connector Part Numbers for the Motor Power Output Connector

Description	Aerotech P/N	Phoenix P/N	Tightening Torque (Nm)	Wire Size: mm ² [AWG]
8-Pin Terminal Block	ECK01424	1803633	0.22 - 0.25	2.0 - 0.516 [14-30]

2.3.1. Brushless Motor Connections

The configuration shown in Figure 2-8 is an example of a typical brushless motor connection.

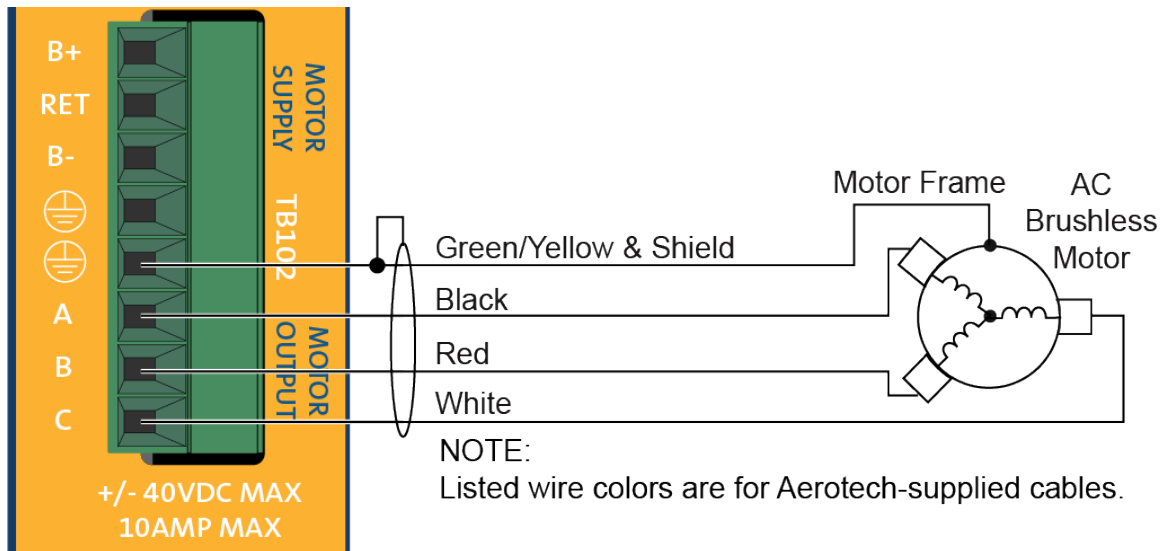

Figure 2-8: Brushless Motor Configuration

Table 2-10: Wire Colors for Aerotech Supplied Cables (Brushless)

Pin	Wire Color Set 1 ⁽¹⁾	Wire Color Set 2	Wire Color Set 3	Wire Color Set 4
⊕	Green/Yellow & Shield ⁽²⁾	Green/Yellow & Shield	Green/Yellow & Shield	Green/Yellow & Shield
A	Black	Blue & Yellow	Black #1	Black & Brown
B	Red	Red & Orange	Black #2	Red & Orange
C	White	White & Brown	Black #3	Violet & Blue

1. Wire Color Set #1 is the typical Aerotech wire set used by Aerotech.
 2. "&" (Red & Orange) indicates two wires; "/" (Green/White) indicates a single wire

Brushless motors are commutated electronically by the controller, typically using Hall-effect devices. If you are using standard Aerotech motors and cables, motor phasing adjustments are not required and this section may be skipped.

The controller requires that the Back-EMF of each motor phase be aligned with the corresponding Hall-effect signal. To ensure proper alignment, motor, Hall, and encoder connections should be verified using one of the following methods: *powered*, through the use of a test program; or *unpowered* using an oscilloscope. Both methods will identify the A, B, and C Hall/motor lead sets and indicate the correct connections to the controller. Refer to Section 2.3.1.1. for powered motor phasing or Section 2.3.1.2. for unpowered motor and feedback phasing.

2.3.1.1. Powered Motor Phasing

Refer to the Motor Phasing Calculator in the Configuration Manager for motor, Hall, and encoder phasing.

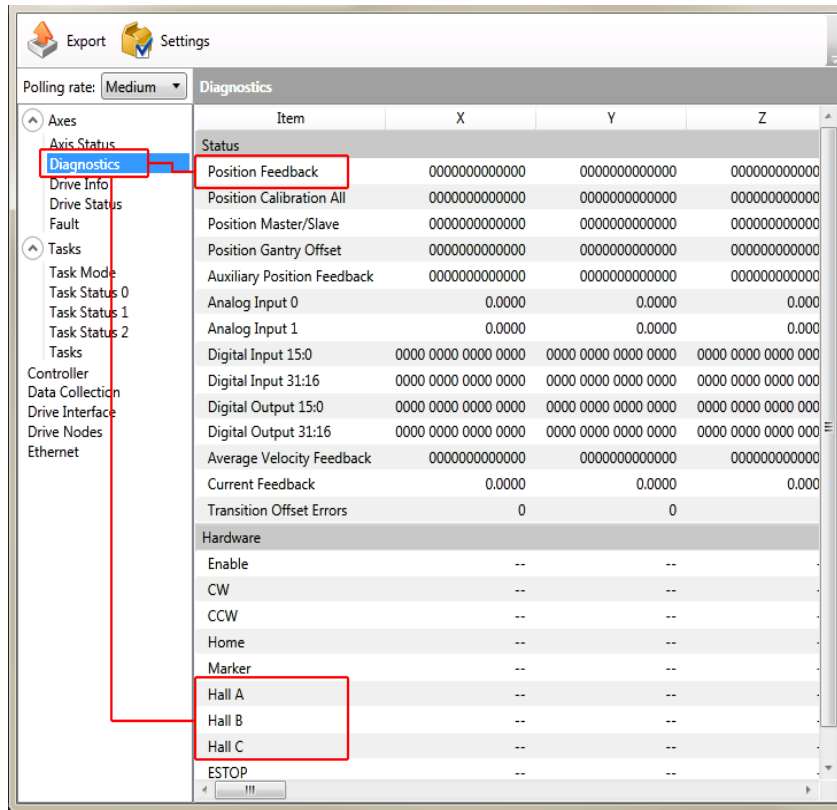

Figure 2-9: Encoder and Hall Signal Diagnostics

2.3.1.2. Unpowered Motor and Feedback Phasing

Disconnect the motor from the controller and connect the motor in the test configuration shown in [Figure 2-10](#). This method will require a two-channel oscilloscope, a 5V power supply, and six resistors (10,000 ohm, 1/4 watt). All measurements should be made with the probe common of each channel of the oscilloscope connected to a neutral reference test point (TP4, shown in [Figure 2-10](#)). Wave forms are shown while moving the motor in the positive direction.

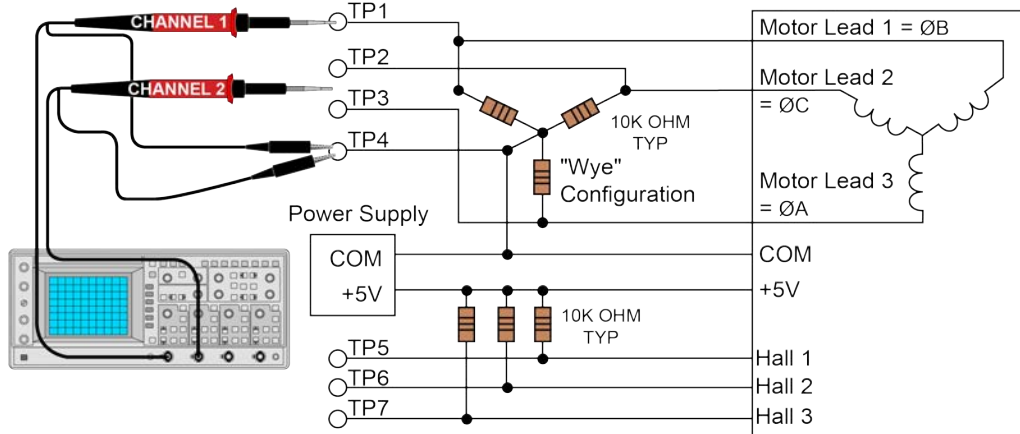

Figure 2-10: Motor Phasing Oscilloscope Example

With the designations of the motor and Hall leads of a third party motor determined, the motor can now be connected to an Aerotech system. Connect motor lead A to motor connector A, motor lead B to motor connector B, and motor lead C to motor connector C. Hall leads should also be connected to their respective feedback connector pins (Hall A lead to the Hall A feedback pin, Hall B to Hall B, and Hall C to Hall C). The motor is correctly phased when the Hall states align with the Back EMF as shown in ([Figure 2-11](#)). Use the CommutationOffset parameter to correct for Hall signal misalignment.

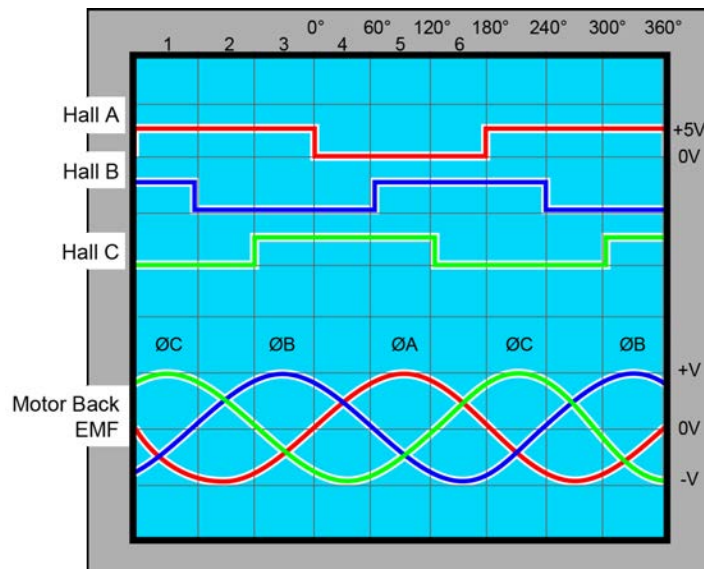

Figure 2-11: Brushless Motor Phasing Goal

2.3.2. DC Brush Motor Connections

The configuration shown in Figure 2-12 is an example of a typical DC brush motor connection. Refer to Section 2.3.2.1. for information on motor phasing.

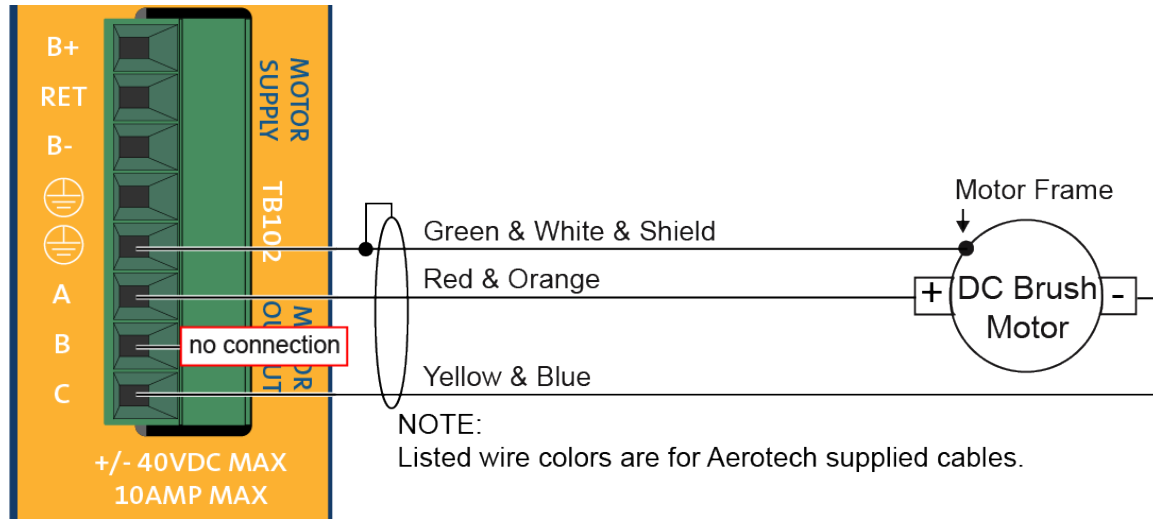

Figure 2-12: DC Brush Motor Configuration

Table 2-11: Wire Colors for Aerotech Supplied Cables (DC Brush)

Pin	Wire Color Set 1 ⁽¹⁾	Wire Color Set 2	Wire Color Set 3
⊕	Green & White & Shield ⁽²⁾	Green/Yellow & Shield	Green/Yellow & Shield
A	Red & Orange	Red	Red & Orange
C	Yellow & Blue	Black	Yellow & Blue

1. Wire Color Set #1 is the typical Aerotech wire set used by Aerotech.

2. “&” (Red & Orange) indicates two wires; “/” (Green/White) indicates a single wire

2.3.2.1. DC Brush Motor Phasing

A properly phased motor means that the positive motor lead should be connected to the $\emptyset A$ motor terminal and the negative motor lead should be connected to the $\emptyset C$ motor terminal. To determine if the motor is properly phased, connect a voltmeter to the motor leads of an un-powered motor:

1. Connect the positive lead of the voltmeter to the one of the motor terminals.
2. Connect the negative lead of the voltmeter to the other motor terminal.
3. Rotate the motor clockwise by hand.

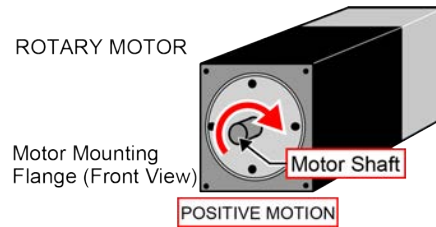

Figure 2-13: Clockwise Motor Rotation

4. If the voltmeter indicates a negative value, swap the motor leads and rotate the motor (CW, by hand) again. When the voltmeter indicates a positive value, the motor leads have been identified.
5. Connect the motor lead from the voltmeter to the $\emptyset A$ motor terminal on the Ndrive ML. Connect the motor lead from the negative lead of the voltmeter to the $\emptyset C$ motor terminal on the Ndrive ML.

NOTE: If using standard Aerotech motors and cables, motor and encoder connection adjustments are not required.

2.3.3. Stepper Motor Connections

The configuration shown in Figure 2-14 is an example of a typical stepper motor connection. Refer to Section 2.3.3.1. for information on motor phasing.

In this case, the effective motor voltage is half of the applied bus voltage. For example, an 80V motor bus supply is needed to get 40V across the motor.

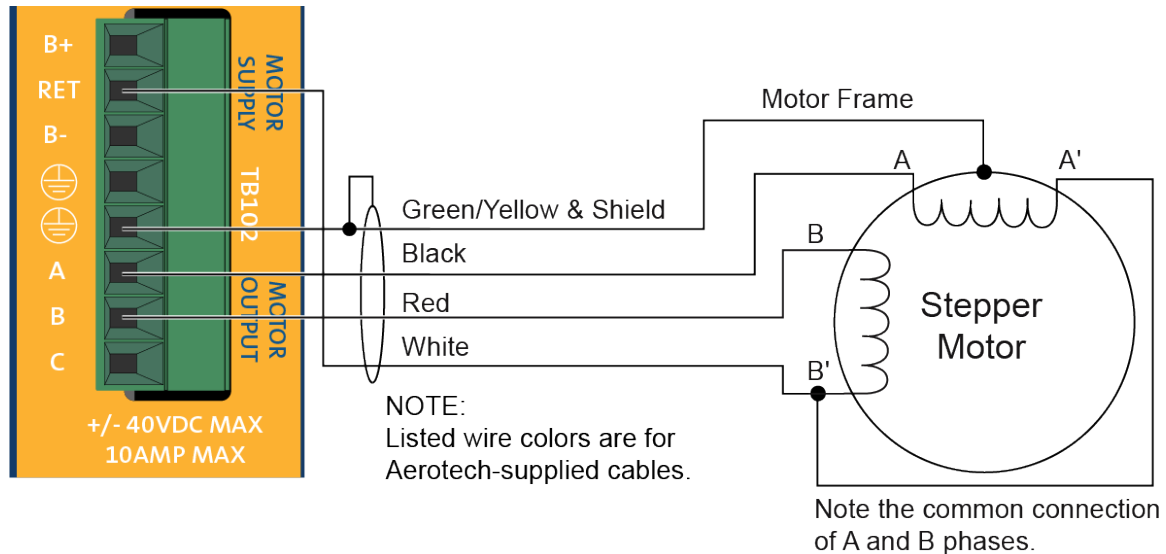

Figure 2-14: Stepper Motor Configuration

Table 2-12: Wire Colors for Aerotech Supplied Cables (Stepper)

Pin	Wire Color Set 1 ⁽¹⁾	Wire Color Set 2
⊕	Green/Yellow & Shield ⁽²⁾	Green/Yellow & Shield
A	Black	Brown
B	Red	Yellow
RET	White	White & Red

1. Wire Color Set #1 is the typical Aerotech wire set used by Aerotech.
2. "&" (Red & Orange) indicates two wires; "/" (Green/White) indicates a single wire

2.3.3.1. Stepper Motor Phasing

NOTE: If using standard Aerotech motors and cables, motor and encoder connection adjustments are not required.

A stepper motor can be run with or without an encoder. If an encoder is not being used, phasing is not necessary. With an encoder, test for proper motor phasing by running a positive motion command.

If there is a positive scaling factor (determined by the CountsPerUnit parameters) and the motor moves in a clockwise direction, as viewed looking at the motor from the front mounting flange, the motor is phased correctly. If the motor moves in a counterclockwise direction, swap the motor leads and re-run the command.

Proper motor phasing is important because the end of travel (EOT) limit inputs are relative to motor rotation.

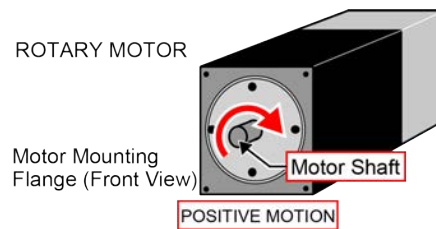

Figure 2-15: Clockwise Motor Rotation

NOTE: After the motor has been phased, use the ReverseMotionDirection parameter to change the direction of “positive” motion.

2.4. Motor Feedback Connections (J103)

The motor feedback connector (a 25-pin, D-style connector) has inputs for an encoder, limit switches, Hall-effect devices, motor over-temperature device, 5 Volt encoder and limit power, and optional brake connection. The connector pin assignment is shown below with detailed connection information in the following sections.

Table 2-13: Motor Feedback Connector Pinout (J103)

Pin#	Description	In/Out/Bi	Connector
1	Chassis Frame Ground	N/A	
2	Motor Over Temperature Thermistor	Input	
3	+5V Power for Encoder (500 mA max)	Output	
4	Reserved	N/A	
5	Hall-Effect Sensor B (brushless motors only)	Input	
6	Encoder Marker Reference Pulse -	Input	
7	Encoder Marker Reference Pulse +	Input	
8	Analog Input 0 -	Input	
9	Reserved	N/A	
10	Hall-Effect Sensor A (brushless motors only)	Input	
11	Hall-Effect Sensor C (brushless motors only)	Input	
12	Clockwise End of Travel Limit	Input	
13	Brake Output -	Output	
14	Encoder Cosine +	Input	
15	Encoder Cosine -	Input	
16	+5V Power for Limit Switches (500 mA max)	Output	
17	Encoder Sine +	Input	
18	Encoder Sine -	Input	
19	Analog Input 0 +	Input	
20	Signal Common for Limit Switches	N/A	
21	Signal Common for Encoder	N/A	
22	Home Switch Input	Input	
23	Encoder Fault Input	Input	
24	Counterclockwise End of Travel Limit	Input	
25	Brake Output +	Output	

Table 2-14: Mating Connector Part Numbers for the Motor Feedback Connector (J103)

Mating Connector	Aerotech P/N	Third Party P/N
25-Pin D-Connector	ECK00101	FCI DB25P064TXLF
Backshell	ECK00656	Amphenol 17E-1726-2

2.4.1. Encoder Interface (J103)

The Ndrive ML is equipped with standard and auxiliary encoder feedback channels. The standard encoder interface is accessible through the Motor Feedback (J103) connector. The standard encoder interface will accept an RS-422 differential line driver signal. If the Ndrive ML has been purchased with the -MXH or -MXU option, the standard encoder interface can be configured for an analog encoder input via parameter settings.

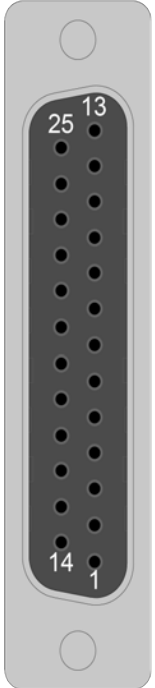
Refer to [Section 2.4.1.3.](#) for encoder feedback phasing.

NOTE: Encoder wiring should be physically isolated from motor, AC power, and all other power wiring.

NOTE: The PSO feature is **not** compatible with the -MXU option. The PSO feature operates with the -MXH option and with square wave encoders.

Table 2-15: Encoder Interface Pins on the Motor Feedback Connector (J103)

Pin#	Description	In/Out/Bi
1	Chassis Frame Ground	N/A
3	+5V Power for Encoder (500 mA max)	Output
6	Encoder Marker Reference Pulse -	Input
7	Encoder Marker Reference Pulse +	Input
14	Encoder Cosine +	Input
15	Encoder Cosine -	Input
17	Encoder Sine +	Input
18	Encoder Sine -	Input
21	Signal Common for Encoder	N/A

2.4.1.1. RS-422 Line Driver Encoder (Standard)

The standard encoder interface accepts an RS-422 differential quadrature line driver signal. Invalid or missing signals will cause a feedback fault when the axis is enabled.

An analog encoder is used with the -MXH/-MXU option (refer to [Section 2.4.1.2.](#) for more information).

Table 2-16: Encoder Specifications

Specification	Value
Encoder Frequency	10 MHz maximum (25 nsec minimum edge separation)
x4 Quadrature Decoding	40 million counts/sec

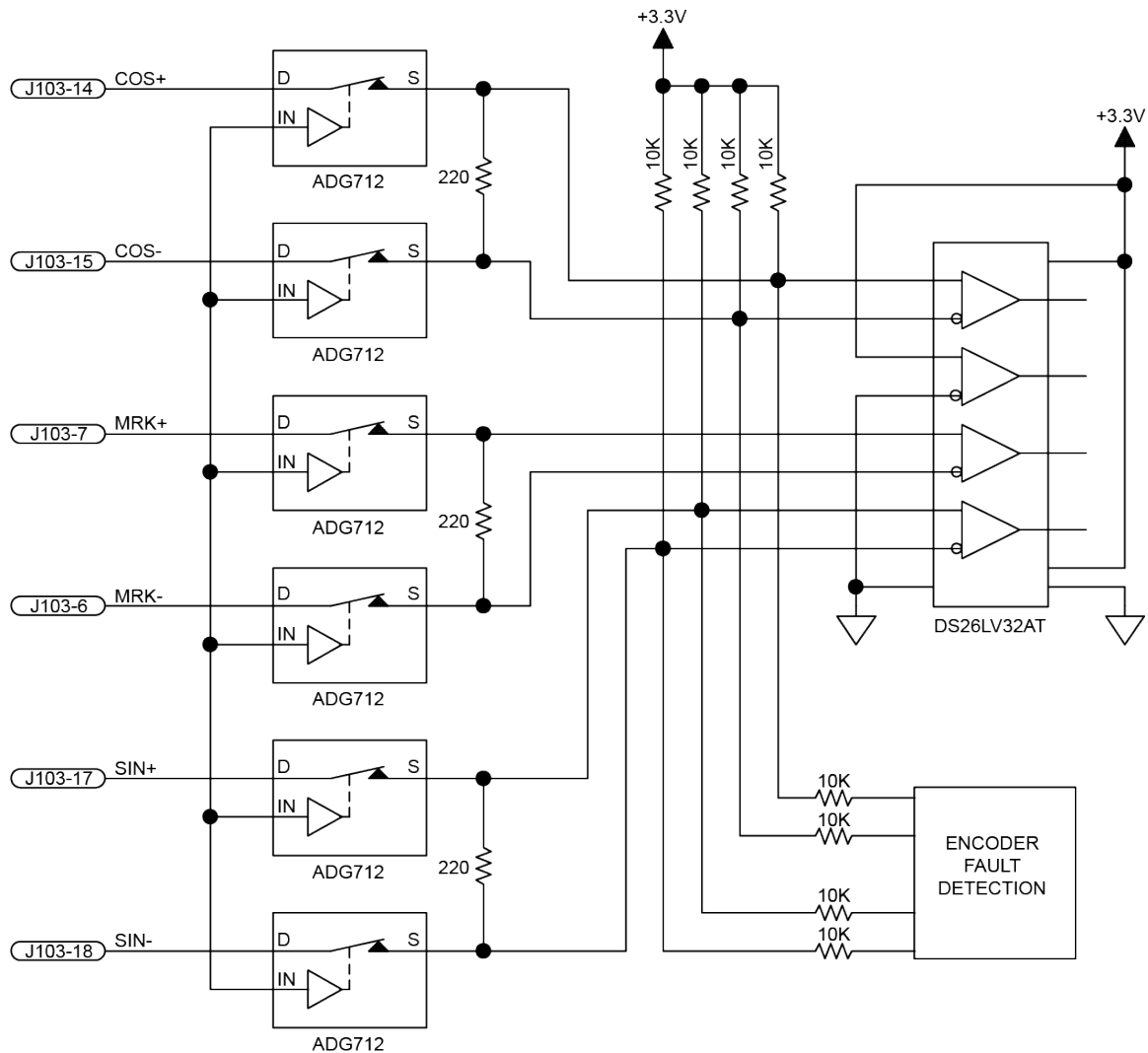

Figure 2-16: Line Driver Encoder Interface (J103)

2.4.1.2. Analog Encoder Interface

If the -MXH/-MXU option has been purchased, the standard encoder channel will accept a differential analog encoder input signal. The interpolation factor is determined by the EncoderMultiplicationFactor parameter and is software selectable (refer to the A3200 Help file).

Table 2-17: Analog Encoder Specifications

Specification	MXU	MXH
Input Frequency (max)	500 kHz	500 kHz
Input Amplitude	0.6 to 2.25 Vpk-Vpk	0.6 to 2.25 Vpk-Vpk
Interpolation Factor (software selectable)	4,096	65,536
MXH Interpolation Latency	N/A	~ 3.25 μ sec (analog input to quadrature output)

Refer to Figure 2-17 for the typical input circuitry.

The encoder interface pin assignment is indicated in Section 2.4.1.

The gain, offset, and phase balance of the analog Sine and Cosine encoder input signals can all be adjusted via controller parameters. Encoder signals should be adjusted using the Feedback Tuning tab of the Digital Scope, which will automatically adjust the encoder parameters for optimum performance. See the A3200 Help file for more information.

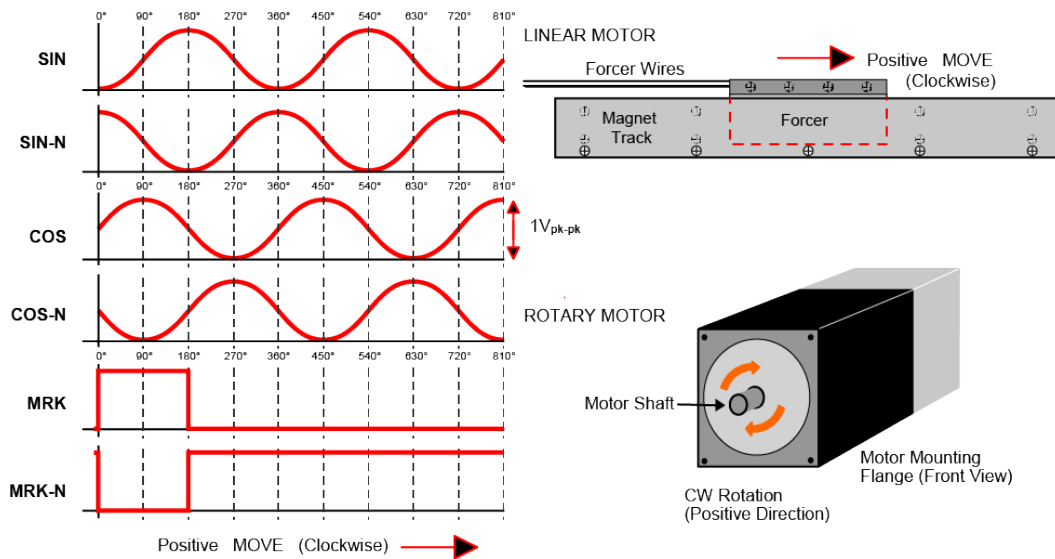

Figure 2-17: Analog Encoder Phasing Reference Diagram

NOTE: The input amplitude is measured peak to peak for any encoder signal (sin, sin-n, cos, cos-n) relative to signal common. These signals have a typical offset voltage of 2V to 2.5V.

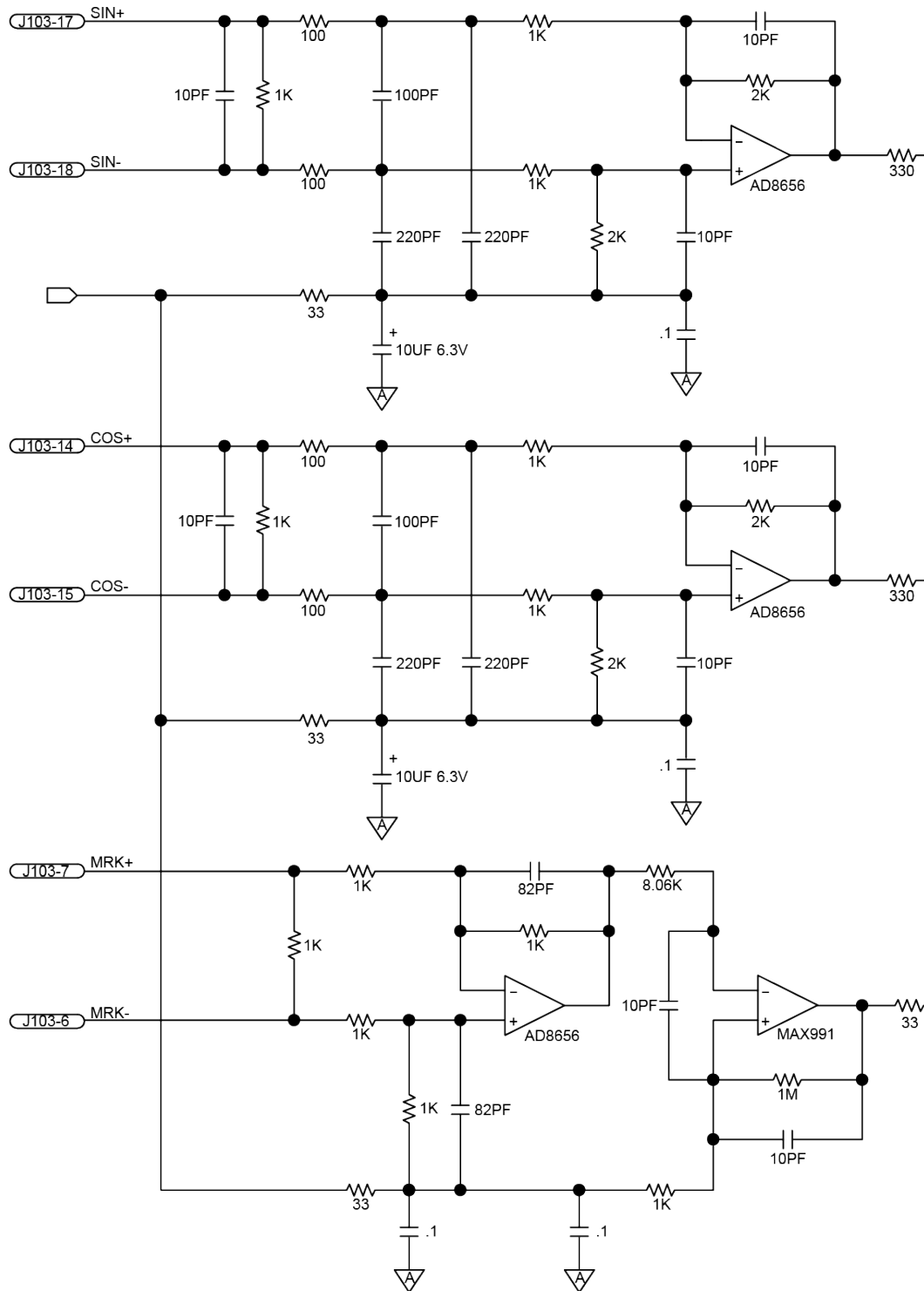

Figure 2-18: Analog Encoder Interface (J103)

2.4.1.3. Encoder Phasing

Incorrect encoder polarity will cause the system to fault when enabled or when a move command is issued. Figure 2-19 illustrates the proper encoder phasing for clockwise motor rotation (or positive forcer movement for linear motors). To verify, move the motor by hand in the CW (positive) direction while observing the position of the encoder in the diagnostics display (see Figure 2-20). The Motor Phasing Calculator in the Configuration Manager can be used to determine proper encoder polarity.

For dual loop systems, the velocity feedback encoder is displayed in the diagnostic display (Figure 2-20).

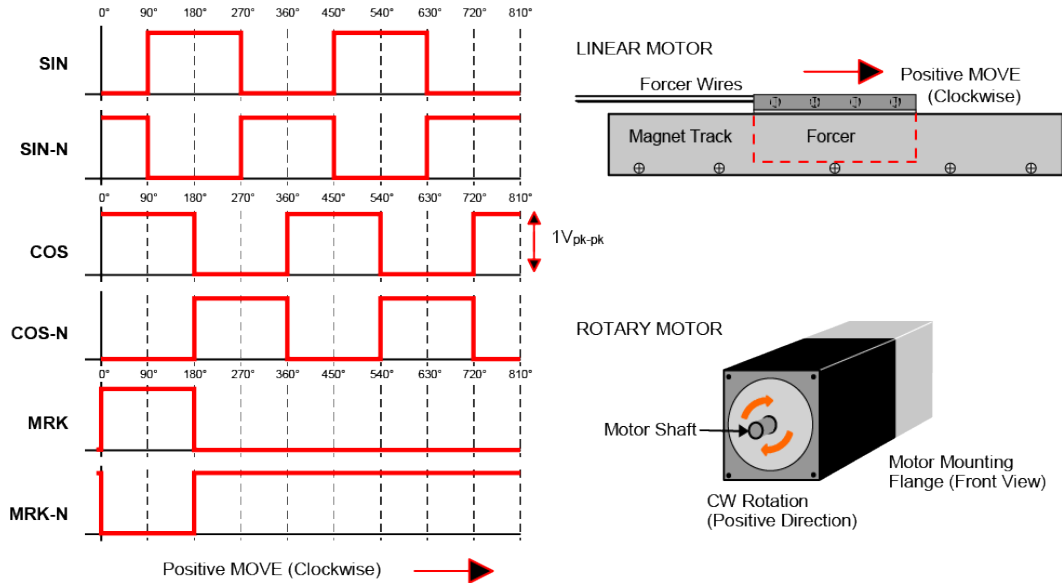

Figure 2-19: Encoder Phasing Reference Diagram (Standard)

NOTE: Encoder manufacturers may refer to the encoder signals as A, B, and Z. The proper phase relationship between signals is shown in Figure 2-19.

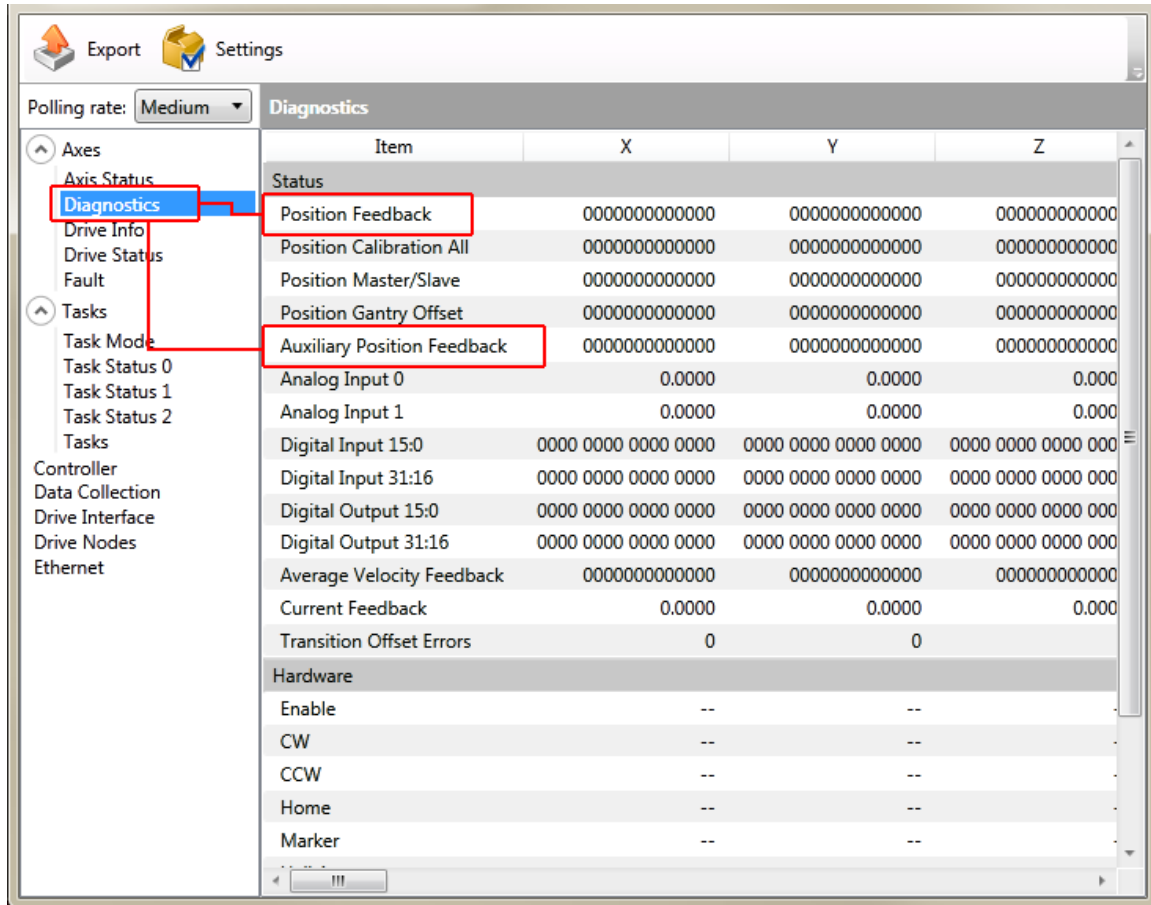

Figure 2-20: Position Feedback in the Diagnostic Display

2.4.2. Hall-Effect Interface (J103)

The Hall-effect switch inputs are recommended for AC brushless motor commutation but not absolutely required. The Hall-effect inputs accept 5-24 VDC level signals. Hall states (0,0,0) or (1,1,1) are invalid and will generate a "Hall Fault" axis fault.

Refer to [Section 2.3.1.1](#) for Hall-effect device phasing.

Table 2-18: Hall-Effect Feedback Pins on the Motor Feedback Connector (J103)

Pin#	Description	In/Out/Bi
1	Chassis Frame Ground	N/A
3	+5V Power for Encoder (500 mA max)	Output
5	Hall-Effect Sensor B (brushless motors only)	Input
10	Hall-Effect Sensor A (brushless motors only)	Input
11	Hall-Effect Sensor C (brushless motors only)	Input
21	Signal Common for Encoder	N/A

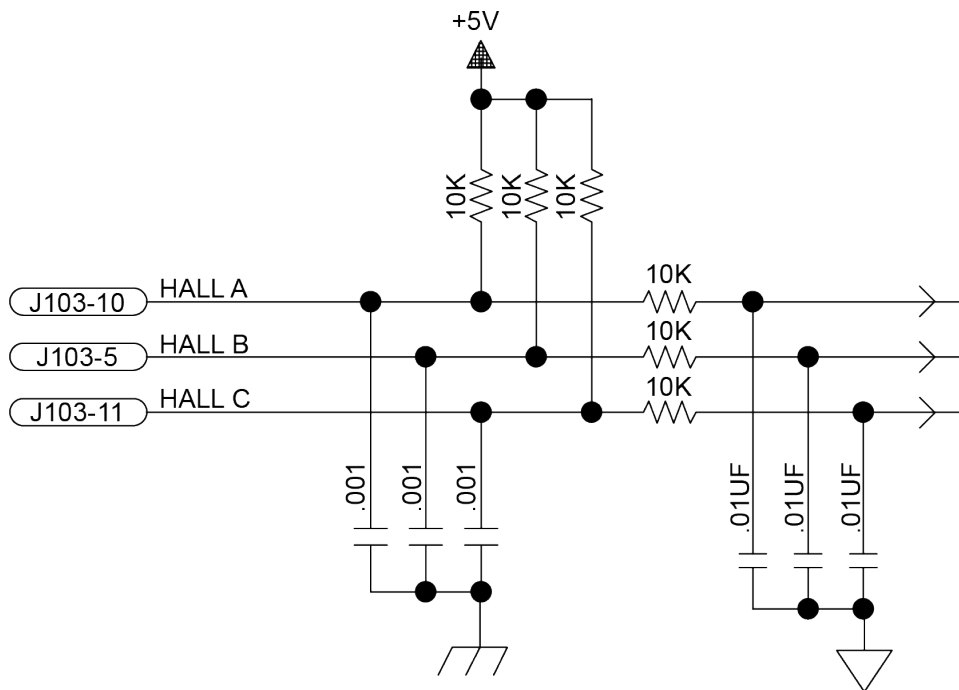

Figure 2-21: Hall-Effect Inputs (J103)

2.4.3. Thermistor Interface (J103)

The thermistor input is used to detect a motor over temperature condition by using a positive temperature coefficient sensor. As the temperature of the sensor increases, so does the resistance. Under normal operating conditions, the resistance of the thermistor is low (i.e., 100 ohms) which will result in a low input signal. As the increasing temperature causes the thermistor’s resistance to increase, the signal will be seen as a logic high triggering an over temperature fault. The nominal trip value of the sensor is 1k Ohm.

Table 2-19: Thermistor Pin on the Motor Feedback Connector (J103)

Pin#	Description	In/Out/Bi
2	Motor Over Temperature Thermistor	Input

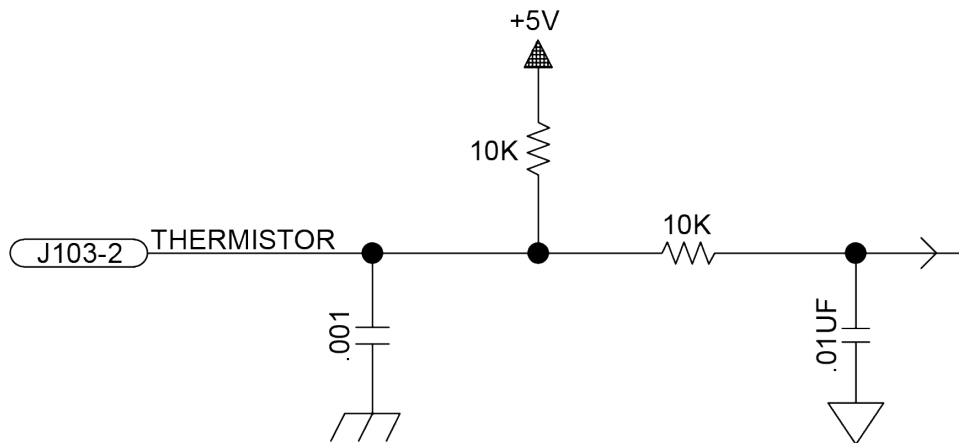

Figure 2-22: Thermistor Interface Input (J103)

2.4.4. Encoder Fault Interface (J103)

The encoder fault input is for use with encoders that have a fault output. This is provided by some manufactures and indicates a loss of encoder function. The active state of this input is parameter configurable and the controller should be configured to disable the axis when the fault level is active.

Table 2-20: Encoder Fault Pin on the Motor Feedback Connector (J103)

Pin#	Description	In/Out/Bi
23	Encoder Fault Input	Input

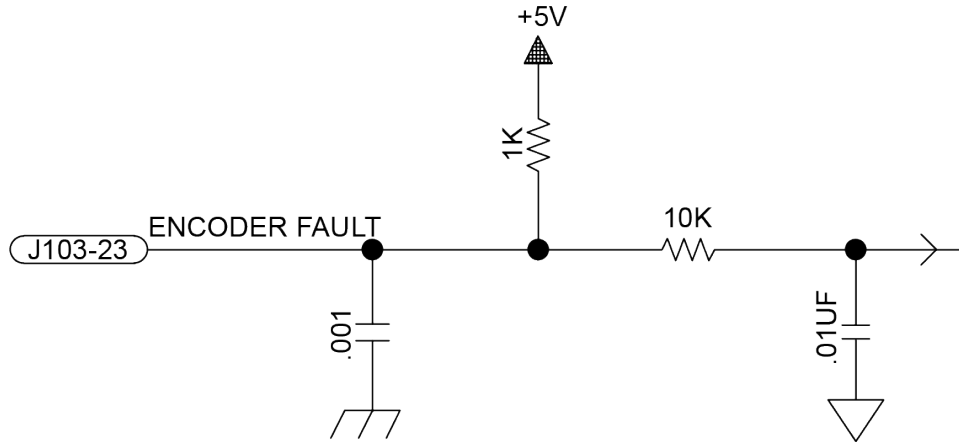

Figure 2-23: Encoder Fault Interface Input (J103)

2.4.5. End Of Travel Limit Input Interface (J103)

End of Travel (EOT) limits are used to define the end of physical travel. The EOT limit inputs accept 5-24 VDC level signals. The active state of the EOT limits is software selectable by the EndOfTravelLimitSetup axis parameter (refer to the A3200 Help file). Limit directions are relative to the encoder polarity in the diagnostics display (refer to [Figure 2-26](#)).

Positive motion is stopped by the clockwise (CW) end of travel limit input. Negative motion is stopped by the counterclockwise (CCW) end of travel limit input. The Home Limit switch can be parameter configured for use during the home cycle, however, the CW or CCW EOT limit is typically used instead.

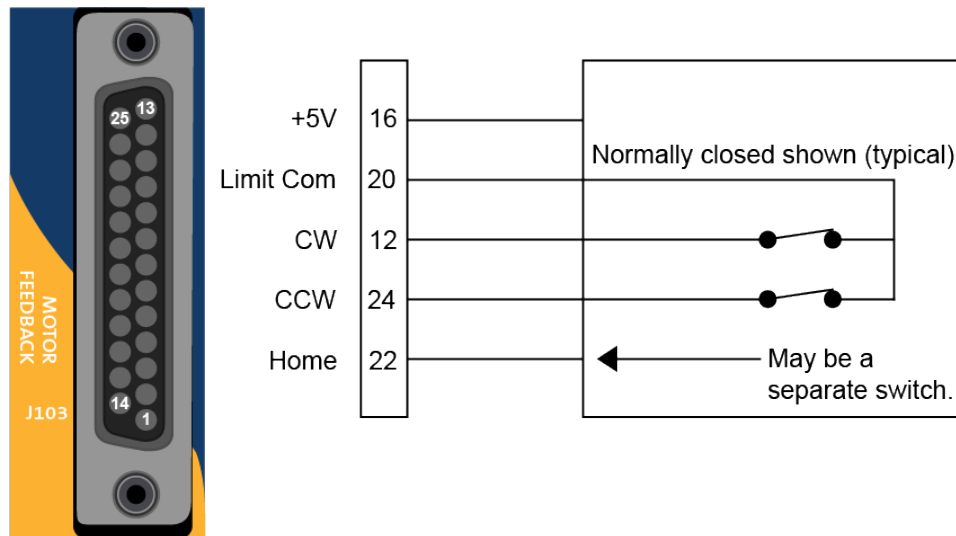

Figure 2-24: End of Travel Limit Input Connections

Table 2-21: End of Travel Limit Input Pins on the Motor Feedback Connector (J103)

Pin#	Description	In/Out/Bi
12	Clockwise End of Travel Limit	Input
16	+5V Power for Limit Switches (500 mA max)	Output
20	Signal Common for Limit Switches	N/A
22	Home Switch Input	Input
24	Counterclockwise End of Travel Limit	Input

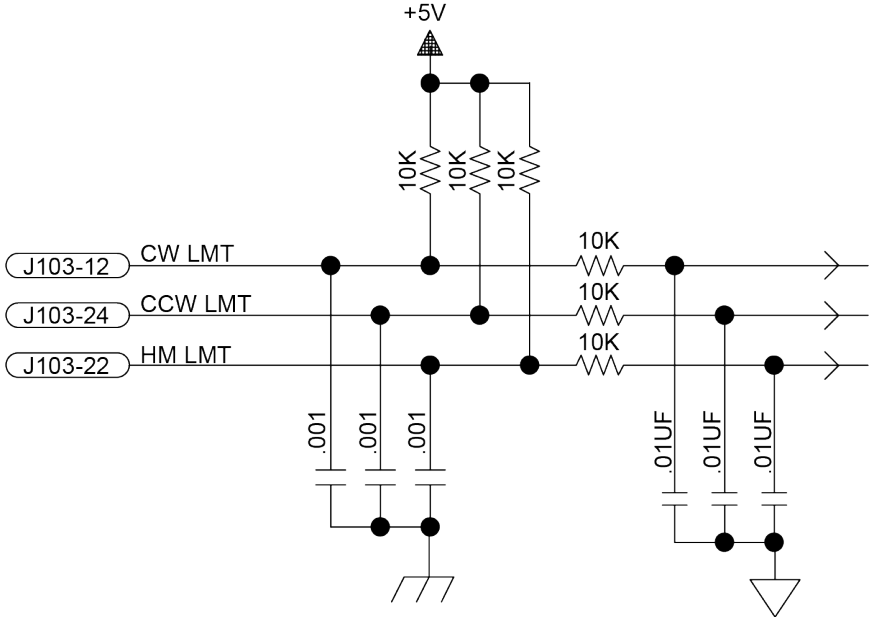

Figure 2-25: End of Travel Limit Interface Input (J103)

2.4.5.1. End Of Travel Limit Phasing

If the EOT limits are reversed, you will be able to move further into a limit but be unable to move out. To correct this, swap the connections to the CW and CCW inputs at the motor feedback connector. The logic level of the EOT limit inputs may be viewed in the Status Utility (shown in [Figure 2-26](#)).

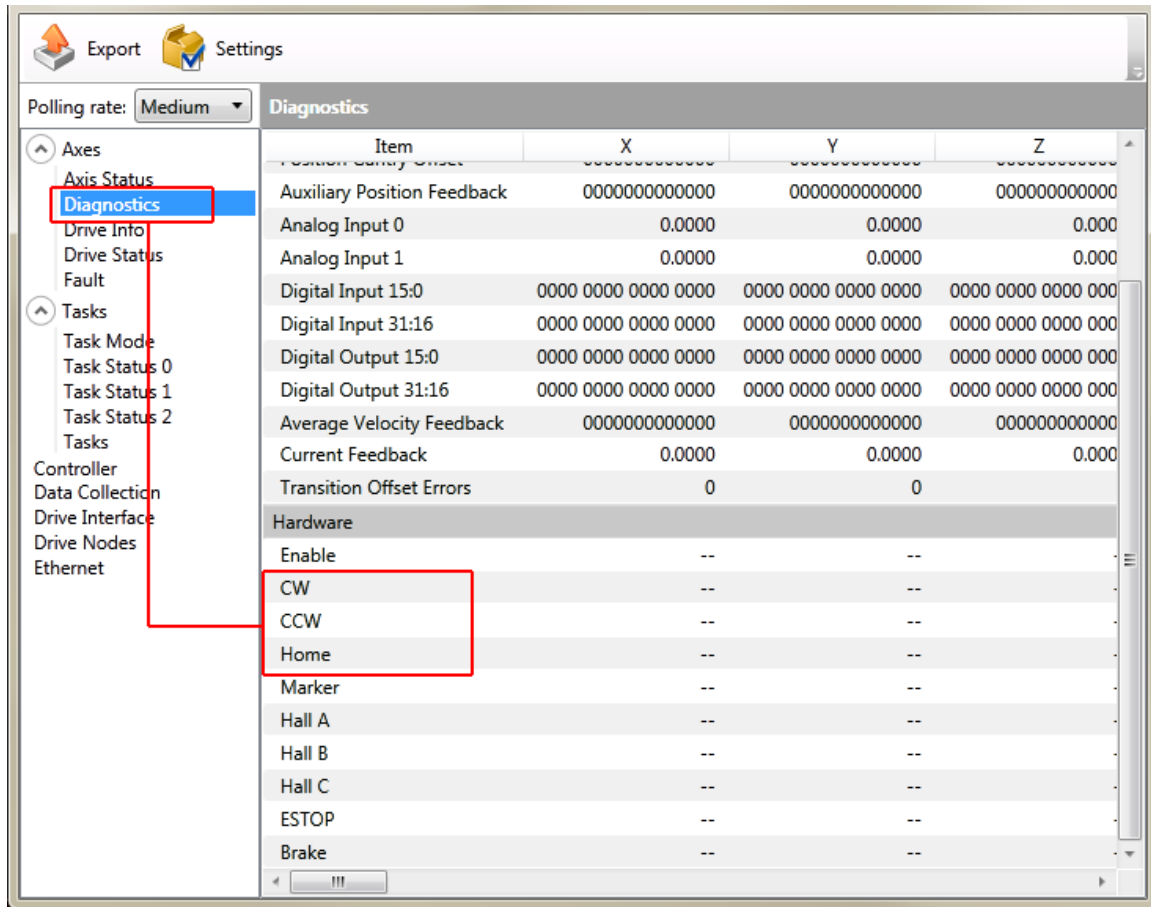

Figure 2-26: Limit Input Diagnostic Display

2.4.6. Brake Output (J103)

The Brake Output pins provide a direct connection to the solid state relay on the optional -IO board. The brake output pins in J103 permit the brake to be wired with other signals in the feedback cable. The brake is configured for automatic or manual control using controller parameters (refer to the A3200 Help file for more information).

Refer to [Section 3.2](#) for more information on using the brake output with the solid-state relay.

Table 2-22: Brake Output Pins on the Motor Feedback Connector (J103)

Pin#	Description	In/Out/Bi
13	Brake Output -	Output
25	Brake Output +	Output

2.4.7. Differential Analog Input 0 (J103)

To interface to a single-ended (non-differential) voltage source, connect the signal common of the source to the negative input and the analog source signal to the positive input. A floating signal source should be referenced to the analog common as shown in [Figure 2-27](#).

Table 2-23: Differential Analog Input 0 Specifications

Specification	Value
(AI+) - (AI-)	+10 V to -10 V ⁽¹⁾
Resolution (bits)	16 bits
Resolution (volts)	305 μ V

1. Signals outside of this range may damage the input

Table 2-24: Differential Analog Input Pins on the Motor Feedback Connector (J103)

Pin#	Description	In/Out/Bi
8	Analog Input 0 -	Input
19	Analog Input 0 +	Input
20	Signal Common for Limit Switches	N/A
21	Signal Common for Encoder	N/A

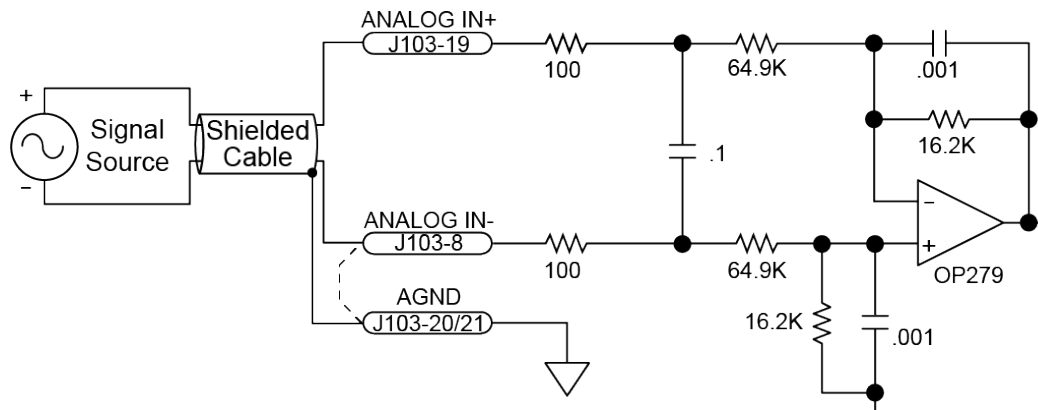

Figure 2-27: Analog Input 0 (J103)

2.5. Emergency Stop Sense Input (TB101)

The ESTOP sense input is used to monitor the state of an external safety circuit only. This state is indicated by the software and may be used to facilitate system restart. This ESTOP sense input is not intended to be a complete safety system.

Refer to [Section 2.5.1](#). for interconnection details.



WARNING: The user is responsible for assessing operator risk levels and designing the external safety circuits appropriately.



WARNING: Opening the motor leads at the Motor Output while the axis is enabled will damage the drive. To protect the drive, the ESTOP circuit should open the DC motor power input (Motor Supply). Refer to [Figure 2-29](#) for interconnection details.

The ESTOP input is scaled for an input voltage of 5-24 volts.

If the ESTOP bit is enabled in the FaultMask axis parameter, the ESTOP input must be driven to prevent the ESTOP fault condition.

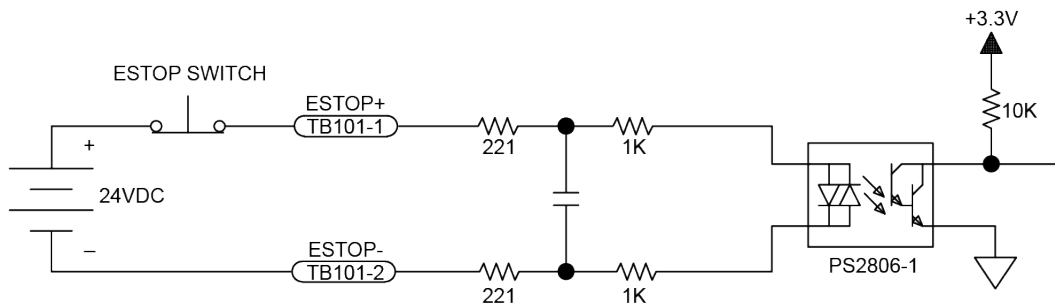

Figure 2-28: ESTOP Sense Input (TB101)

NOTE: Connecting the ESTOP input to a relay or other noise producing device requires the use of noise suppression devices such as those in [Table 2-25](#). These devices are applied across the switched coil to suppress transient voltages.

Table 2-25: Electrical Noise Suppression Devices

Device	Aerotech P/N	Third Party P/N
RC (.1uf / 200 ohm) Network	EIC00240	Electrocube RG1782-8
Varistor	EID00160	Littelfuse V250LA40A

Table 2-26: Mating Connector Part Numbers for the ESTOP Connector (TB101)

Description	Aerotech P/N	Phoenix P/N	Tightening Torque (Nm)	Wire Size: AWG [mm ²]
2-Pin Terminal Block	ECK01250	1803578	0.22 - 0.25	0.14 - 1.5 [26-16]

2.5.1. Typical ESTOP Interface

The user can connect an external emergency stop relay circuit to the Ndrive ML’s motor power supply input. This will remove power to the motor while maintaining control power, as shown in the [Figure 2-29](#).

The external relay must be sized based on the number of the Ndrive MLs connected and the peak current rating of each drive.

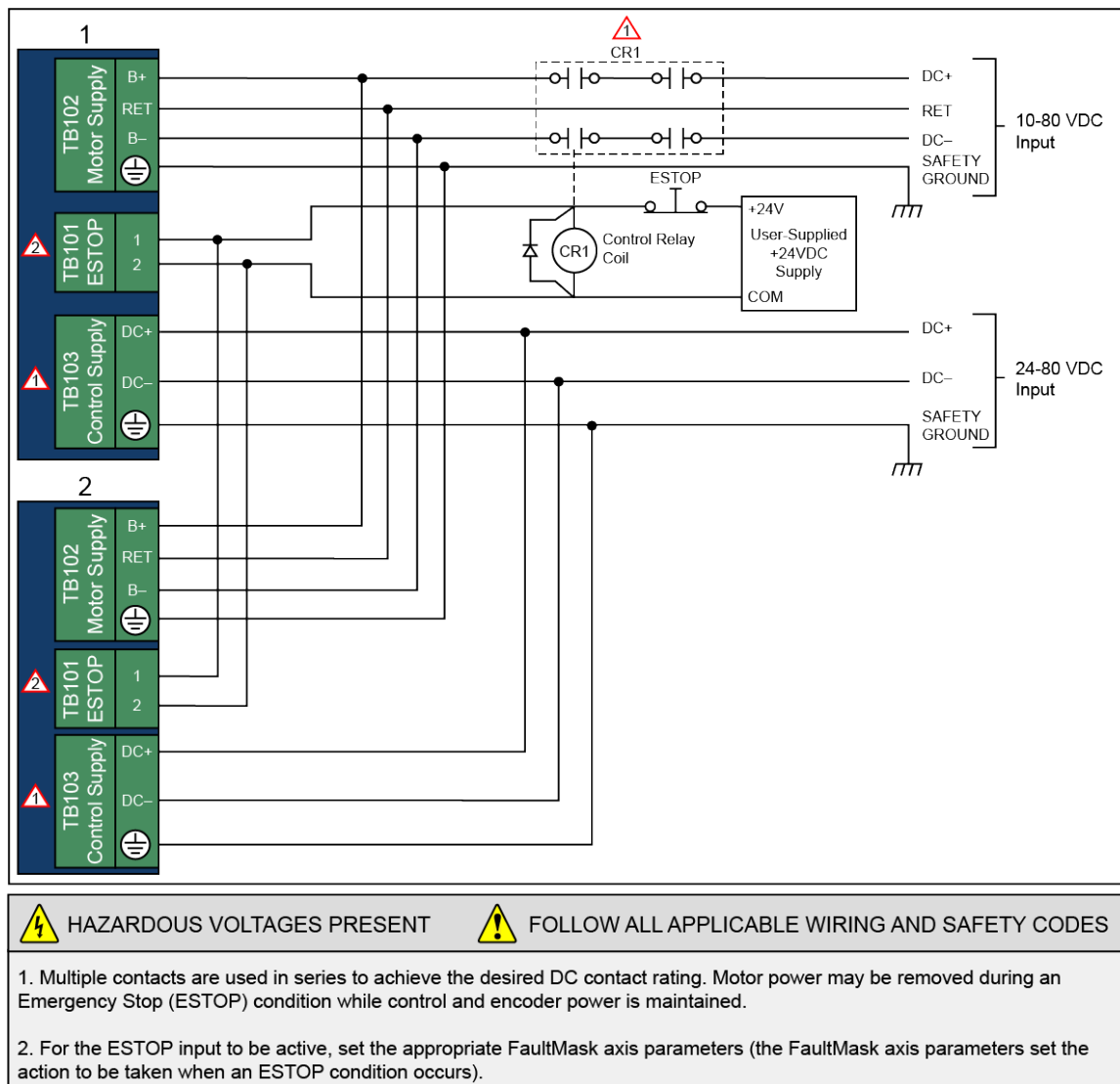

Figure 2-29: Typical Emergency Stop Circuit

Table 2-27: Typical ESTOP Relay Ratings

Axes	DC1	Aerotech P/N	Third Party P/N
Up to 5	32	ECW01024	Sprecher & Schuh CA7-16C-M40-24D

NOTE: Multiple contacts are used in series to achieve desired DC contact rating.

2.6. FireWire Interface

The FireWire bus is the high-speed communications connection to the Ndrive ML operating at 400 megabits per second. All command and configuration information is sent via the FireWire port.

Table 2-28: FireWire Card Part Numbers

Part Number	Description
NFIRE-PCI	OHCI compliant FireWire PCI interface card, 3 port
NFIRE-PCIE	OHCI compliant FireWire PCIe x1 interface card, 2 port
NFIRE-PCI-TI-LP	Low Profile, OHCI compliant, PCI
NFIRE-PCIE-GOF	FireWire PCIE X1 Glass Optical Fiber Board

Table 2-29: FireWire Repeaters (for cables exceeding 4.5 m (15 ft) specification)

Part Number	Description
NFIRE-RPTR-1394A-1394A	Extender for copper cable lengths greater than 4.5 m (15 feet).
NFIRE-RPTR-1394A-GOF	Glass Optical Fiber FireWire Repeater, Qty. 1 (Fiber Cable not included)

Table 2-30: FireWire Cables (copper and glass fiber)

Part Number	Description
NCONNECT-60	6 m (20 ft) long, 6 pin to 6 pin
NCONNECT-45	4.5 m (15 ft) long, 6 pin to 6 pin
NCONNECT-30	3 m (10 ft) long, 6 pin to 6 pin
NCONNECT-15	1.5 m (5 ft) long, 6 pin to 6 pin
NCONNECT-9	0.9 m (3 ft) long, 6 pin to 6 pin
NCONNECT-10000-GOF	10 m (32.8 ft), glass fiber optical cable
NCONNECT-15000-GOF	15 m (49.2 ft), glass fiber optical cable
NCONNECT-20000-GOF	20 m (65.6 ft), glass fiber optical cable
NCONNECT-30000-GOF	30 m (101.7 ft), glass fiber optical cable

2.7. PC Configuration and Operation Information

For additional information about PC configuration, hardware requirements, programming, utilities, and system operation refer to the A3200 Help file.

This page intentionally left blank.

Chapter 3: -I/O Expansion Board

The -IO option board is 8 digital opto-inputs, 8 digital opto-outputs, 1 analog input, 1 analog output, a second encoder channel, and a brake/relay output.



DANGER: Always disconnect the Mains power connection before opening the Ndrive ML chassis.

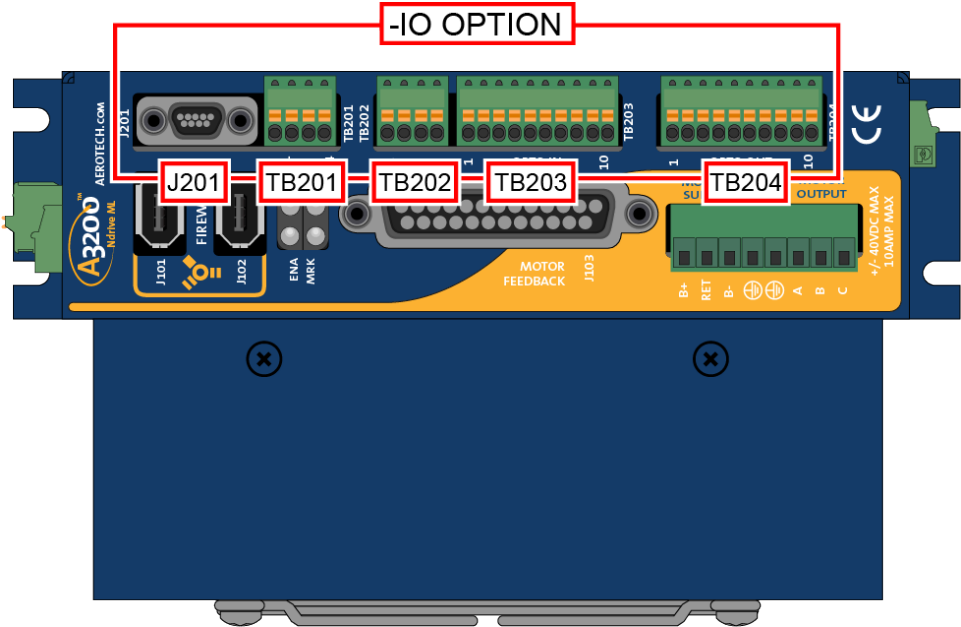

Figure 3-1: Ndrive ML with -IO Option Board

3.1. User Power (TB201)

A user accessible power supply (+5V at 0.5 A) is available between the TB201 pin 3 +5V terminal and TB201 pin 4 GND terminal.

Table 3-1: User Common Connector Pins on the Brake Relay Connector (TB201)

Pin#	Description	In/Out/BI
3	Internal +5 Volt Power Supply (0.5 A max)	Output
4	Signal Common	N/A

3.2. Brake Relay Connector (TB201)

TB201 is the power supply connection to the onboard solid state brake control relay. The relay can be used to automatically control a fail-safe brake on a vertical axis. It can also be used as a general purpose output.

The brake is typically wired directly to the Motor Feedback connector and the brake power supply is connected to TB201 (shown in [Figure 3-2](#)). The brake may also be connected in series with the Brake Power Supply and interlocked using Motor Feedback brake pins ([Figure 3-3](#)). A varistor must be connected across the brake to minimize high voltage transients.

The brake output can be software configured; refer to the A3200 Help file for more information (see topics for the EnableBrakeControl parameter and the BRAKE command).

NOTE: The brake power supply must be externally fused.

The user must verify that the brake power requirements are within the specifications of the brake control relay.

Table 3-2: Relay Specifications

Solid State Relay Rating	
Maximum Voltage	24 VDC
Maximum Current	2.5 Amps
Turn-On/Turn-Off Time	< 3.2 ms Turn-On (typical) / 0.1 ms Turn-Off (typical)



WARNING: Do not exceed the maximum specifications.

Table 3-3: Brake Relay Connector Pinout (TB201)

Pin#	Description	In/Out/BI
1	Brake Power Supply (+)	Input
2	Brake Power Supply (-)	Input

Table 3-4: Mating Connector Part Numbers for the Brake Relay Connector (TB201)

Type	Aerotech P/N	Phoenix P/N	Wire Size: AWG [mm ²]
4-Pin Terminal Block	ECK01293	1881341	20-28 [0.5- 0.080]

Figure 3-2 is an example of a +24 VDC brake connected to the Motor Feedback connector. In this example the external +24 VDC power source is connected to TB201.

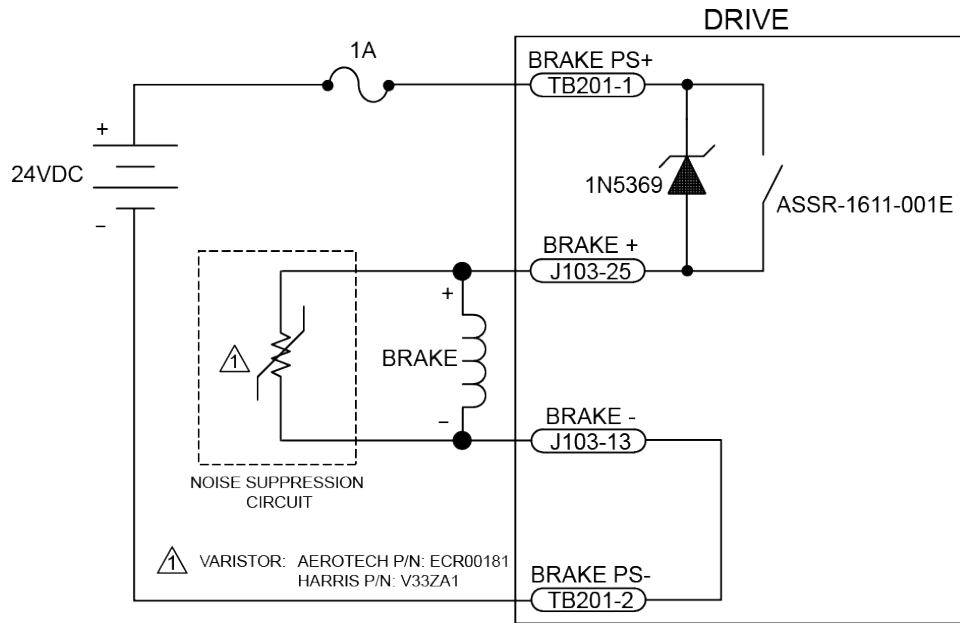

Figure 3-2: Brake Connected to J103

NOTE: The user is responsible for providing fuse protection for the brake circuit.

Figure 3-3 is an example of a 24 VDC brake connected to TB201. The user must connect J103 pin 13 to J103 pin 25. In this case, J103 would function as an interlock to prevent the brake from releasing if the Motor Feedback connector is not connected.

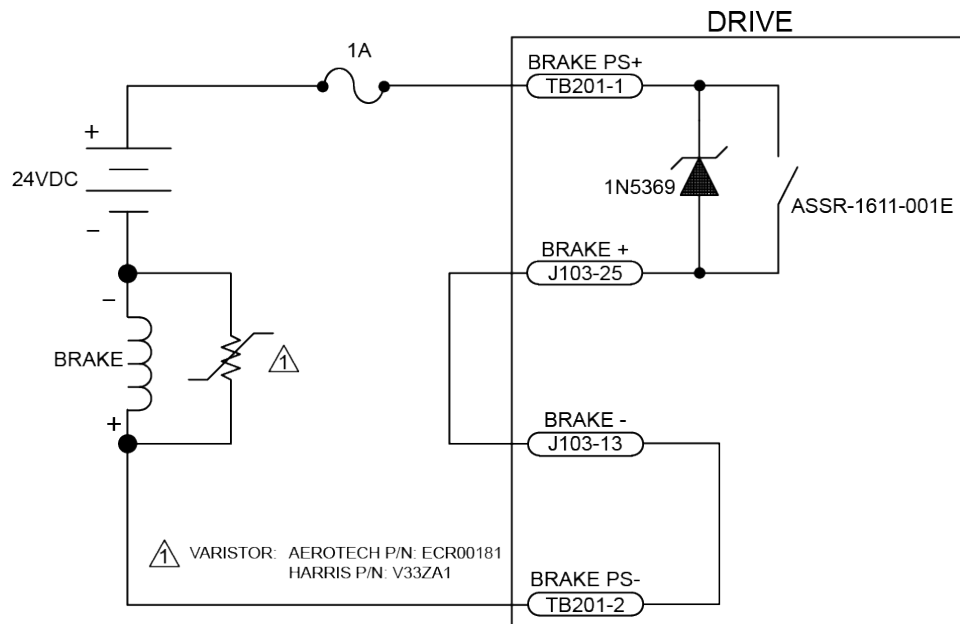

Figure 3-3: Brake Connected to TB201

3.3. Analog I/O Connector (TB202)

The Analog I/O connector has one differential analog input and one isolated analog output.

Table 3-5: Analog Output Connector Pinout (TB202)

Pin#	Description	In/Out/Bi
1	Analog Common	N/A
2	Non-inverting Analog Input 1	Input
3	Inverting Analog Input 1	Input
4	Analog Output 1	Output

Table 3-6: Mating Connector Part Numbers for the Analog Output Connector (TB202)

Type	Aerotech P/N	Phoenix P/N	Wire Size: AWG [mm ²]
4-Pin Terminal Block	ECK01293	1881341	20-28 [0.5- 0.080]

3.3.1. Analog Output 1 (TB202)

The analog output is set to zero when power is first applied to the system or during a system reset.

NOTE: The Ndrive ML does not have an "Analog Output 0".

Table 3-7: Analog Output 1 Specifications (TB202)

Specification	Value
Output Voltage	-5 V to +5 V
Output Current	5 mA
Resolution (bits)	16 bits
Resolution (volts)	153 μ V

Table 3-8: Analog Output Pins on the Analog I/O Connector (TB202)

Pin#	Description	In/Out/Bi
1	Analog Common	N/A
4	Analog Output 1	Output

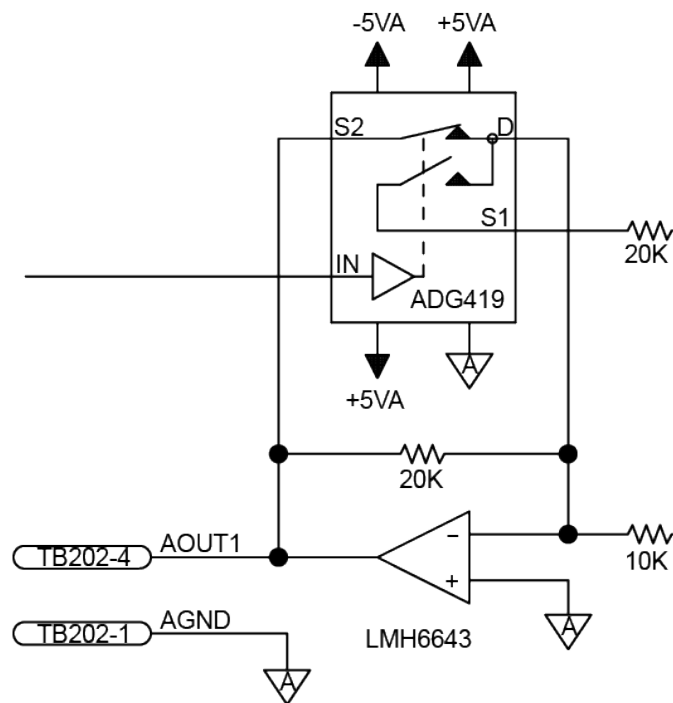

Figure 3-4: Analog Output 1 (TB202)

3.3.2. Differential Analog Input 1 (TB202)

To interface to a single-ended (non-differential) voltage source, connect the signal common of the source to the negative input and the analog source signal to the positive input. A floating signal source should be referenced to the analog common as shown in [Figure 3-5](#).

Table 3-9: Differential Analog Input 1 Specifications

Specification	Value
(AI+) - (AI-)	+10 V to -10 V ⁽¹⁾
Resolution (bits)	16 bits
Resolution (volts)	305 μ V
1. Signals outside of this range may damage the input	

NOTE: Analog Input 0 is available on J103 (see [Section 2.4.7.](#)).

Table 3-10: Differential Analog Input 1 Pins on the Analog I/O Connector (TB202)

Pin#	Description	In/Out/Bi
1	Analog Common	N/A
2	Non-inverting Analog Input 1	Input
3	Inverting Analog Input 1	Input

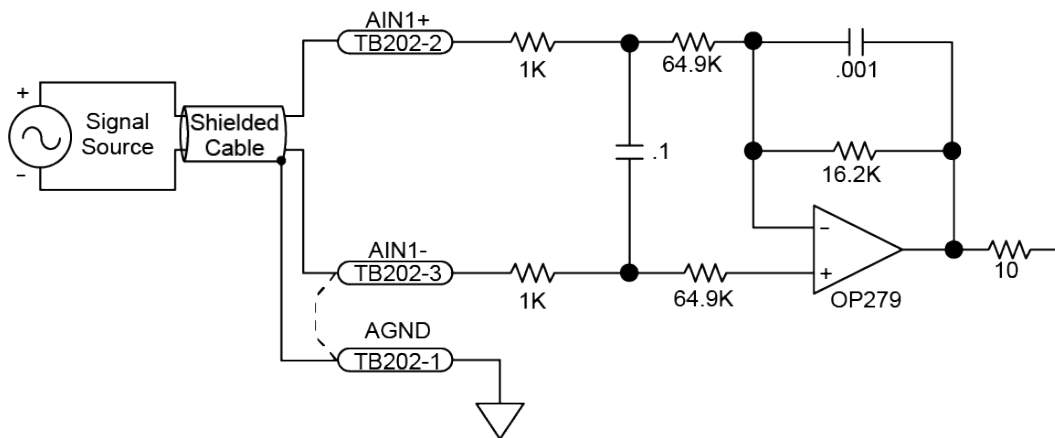

Figure 3-5: Analog Input Typical Connection (TB202)

3.4. Opto In Connector (Digital Inputs) (TB203)

The digital inputs are opto-isolated and may be connected to current sourcing or current sinking devices, as shown in [Figure 3-7](#) and [Figure 3-8](#). These inputs are designed to connect to other ground-referenced circuits and are not intended for high-voltage isolation.

Inputs 0-3 and inputs 4-7 have separate common inputs (refer to [Table 3-12](#)). Each 4-bit bank of inputs must be connected in the same configuration (sinking or sourcing). Bank 1 can be connected differently from Bank 2, however.

The opto-isolator's common connections can be directly connected to the drive's power supply; however, doing so will effectively defeat the isolation and will reduce noise immunity.

Table 3-11: Digital Input Specifications

Input Voltage	Approximate Input Current	Turn On Time	Turn Off Time
+5 V	1 mA	200 usec	2000 usec
+24 V	6 mA	4 usec	1500 usec

Table 3-12: Opto In Connector Pinout (TB203)

Pin#	Description	In/Out/Bi
1	Digital Input Common for inputs 0 - 3	Input
2	Digital Input 0 (Optically-Isolated)	Input
3	Digital Input 1 (Optically-Isolated)	Input
4	Digital Input 2 (Optically-Isolated)	Input
5	Digital Input 3 (Optically-Isolated)	Input
6	Digital Input 4 (Optically-Isolated)	Input
7	Digital Input 5 (Optically-Isolated)	Input
8	Digital Input 6 (Optically-Isolated)	Input
9	Digital Input 7 (Optically-Isolated)	Input
10	Digital Input Common for inputs 4 - 7	Input

Table 3-13: Mating Connector Part Numbers for the Opto In Connector (TB203)

	Aerotech P/N	Phoenix P/N	Wire Size: mm ² [AWG]
10-Pin Terminal Block	ECK01294	1881406	0.5-0.080 [20-28]

NOTE: Inputs must be connected in the all sourcing or all sinking configuration.

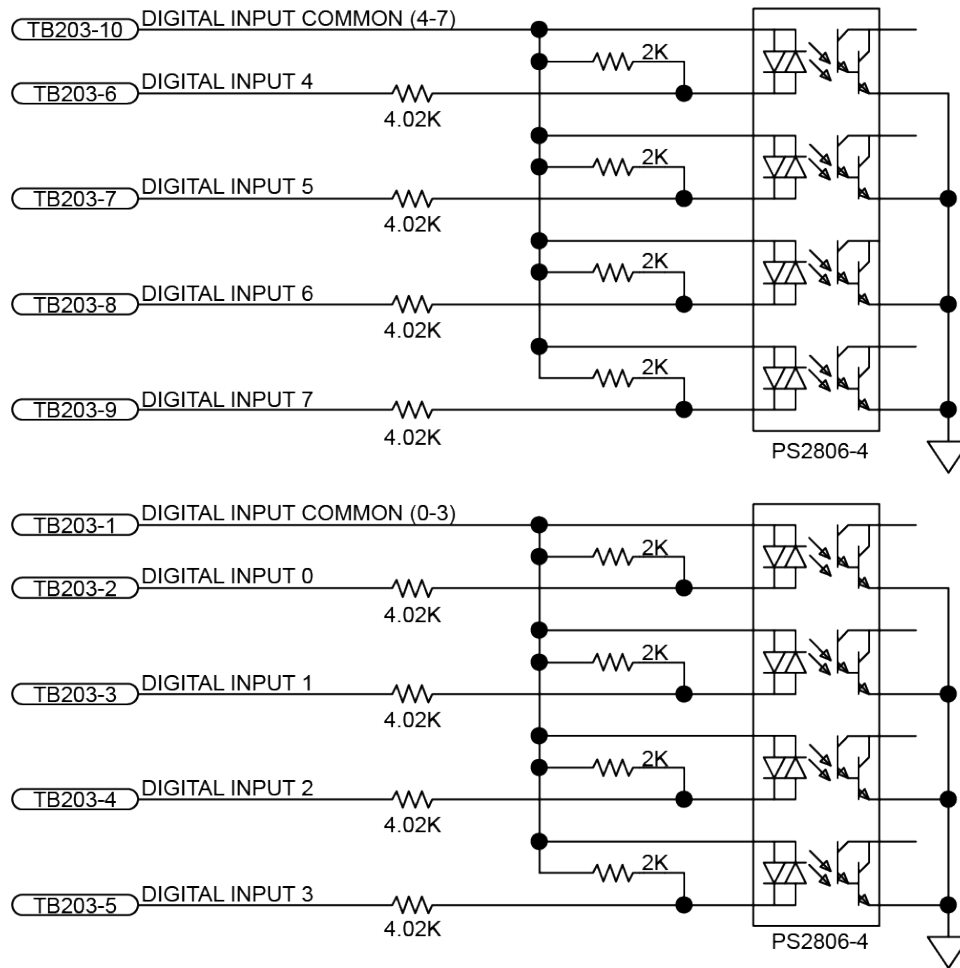

Figure 3-6: Digital Opto-Isolated Inputs

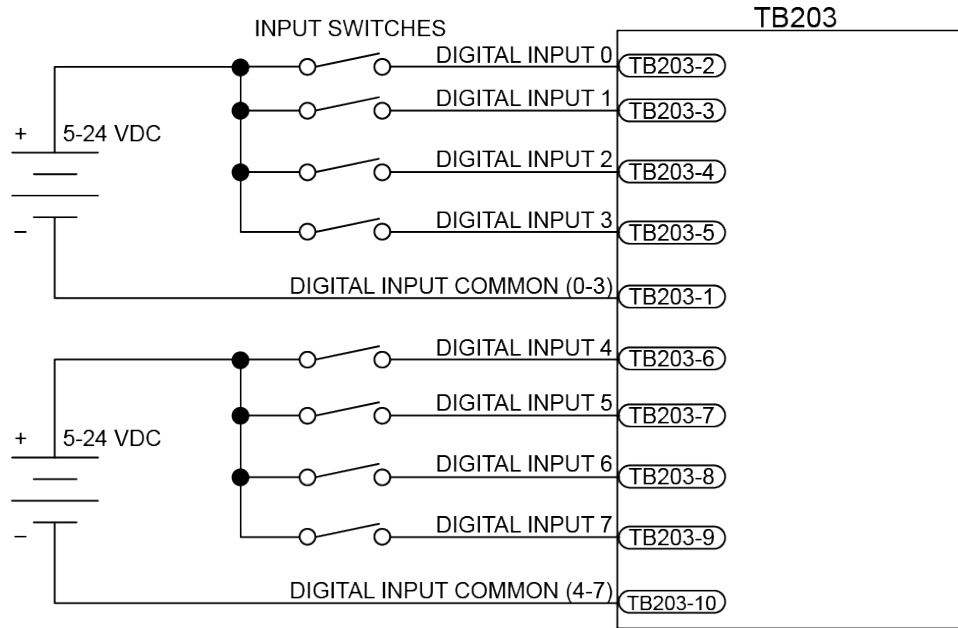

Figure 3-7: Digital Inputs Connected to a Current Sourcing Device

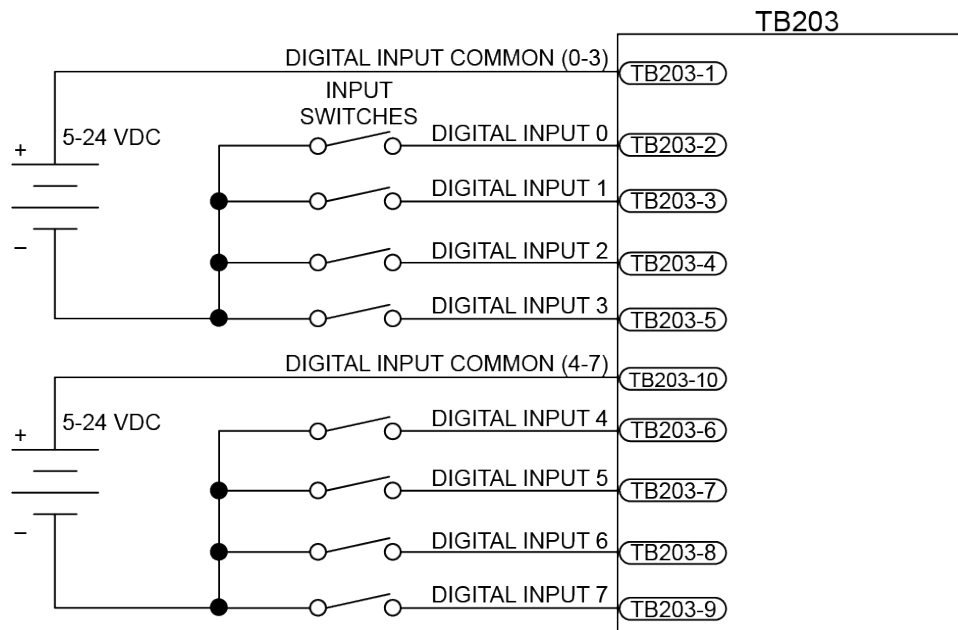

Figure 3-8: Digital Inputs Connected to a Current Sinking Device

3.5. Opto Out Connector (Digital Outputs) (TB204)

The digital outputs are optically-isolated and can be connected in sourcing or sinking configurations. The digital outputs are designed to connect to other ground referenced circuits and are not intended to provide high-voltage isolation.

The outputs are software-configurable and must be connected in either all sinking or all sourcing mode. [Figure 3-10](#) and [Figure 3-11](#) illustrate how to connect to an output in current sourcing and current sinking modes.

The opto-isolator's common connections can be directly connected to the drive's power supply; however, doing so will effectively defeat the isolation and will reduce noise immunity.

Table 3-14: Digital Output Specifications (TB204)

Opto Device Specifications	Value
Maximum Voltage	24 V maximum
Maximum Sink/Source Current	60 mA/channel @ 50°C
Output Saturation Voltage	2.75 V at maximum current
Output Resistance	33 Ω
Rise / Fall Time	250 usec (typical)
Reset State	Output Off (High Impedance State)

NOTE: Power supply connections must always be made to both the Output Common Plus (OP) and Output Common Minus (OM) pins as shown in [Figure 3-10](#) and [Figure 3-11](#).

Table 3-15: Opto Out Connector Pinout TB204)

Pin#	Description	In/Out/Bi
1	Digital Output Common Plus	Input
2	Digital Output Common Minus	Input
3	Digital Output 0 (Optically-Isolated)	Output
4	Digital Output 1 (Optically-Isolated)	Output
5	Digital Output 2 (Optically-Isolated)	Output
6	Digital Output 3 (Optically-Isolated)	Output
7	Digital Output 4 (Optically-Isolated)	Output
8	Digital Output 5 (Optically-Isolated)	Output
9	Digital Output 6 (Optically-Isolated)	Output
10	Digital Output 7 (Optically-Isolated)	Output

Table 3-16: Mating Connector for the Opto Out Connector (TB204)

	Aerotech P/N	Phoenix P/N	Wire Size: mm ² [AWG]
10-Pin Terminal Block	ECK01294	1881406	0.5-0.080 [20-28]

Suppression diodes must be installed on outputs driving relays or other inductive devices. This protects the outputs from damage caused by inductive spikes. Suppressor diodes, such as the 1N914, can be installed on all outputs to provide protection. It is important that the diode be installed correctly (normally reversed biased). Refer to [Figure 3-11](#) for an example of a current sinking output with diode suppression and [Figure 3-10](#) for an example of a current sourcing output with diode suppression.

NOTE: Outputs must be connected as all sourcing or all sinking.

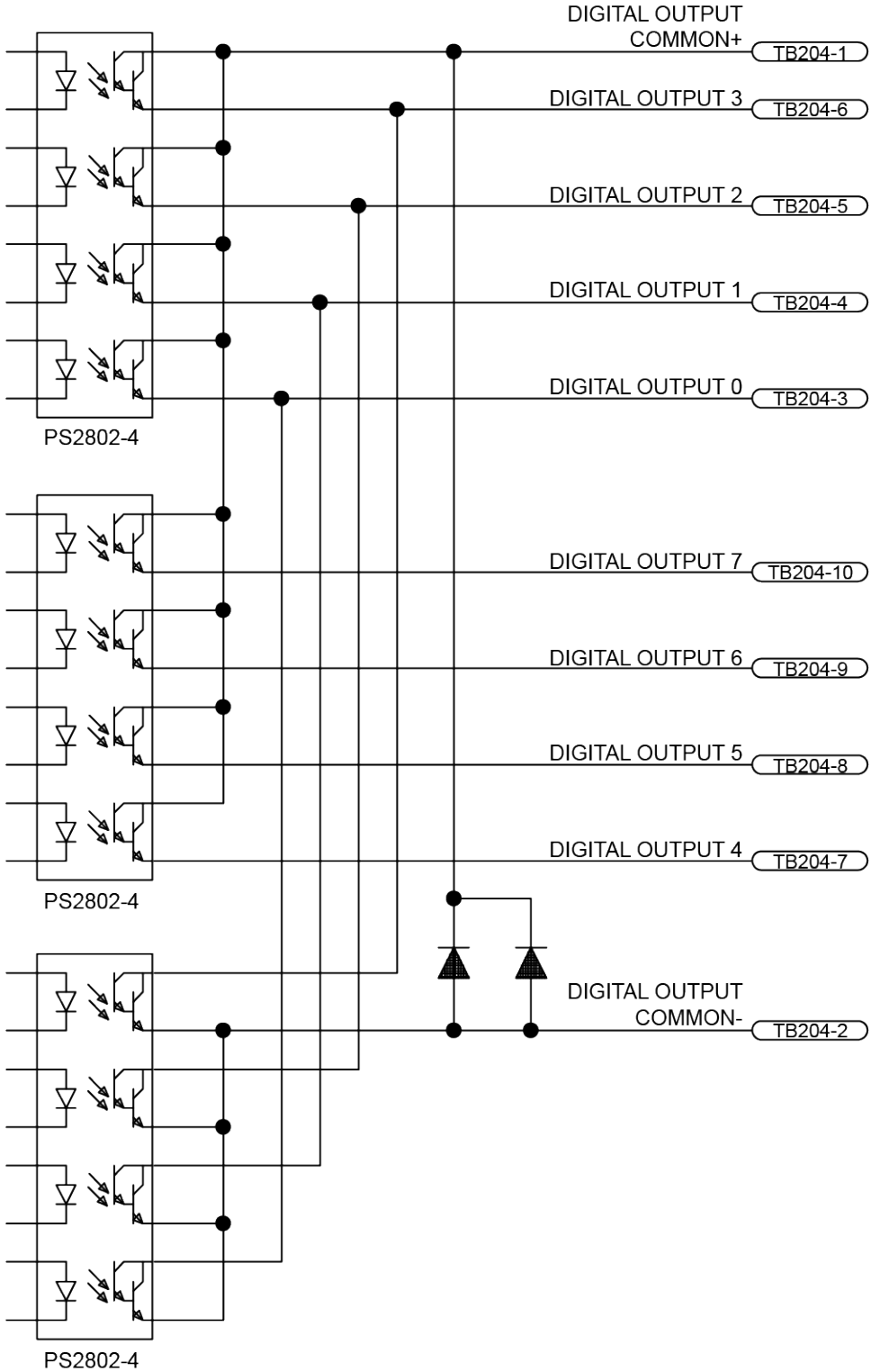

Figure 3-9: Digital Opto-Isolated Outputs (-IO Board)

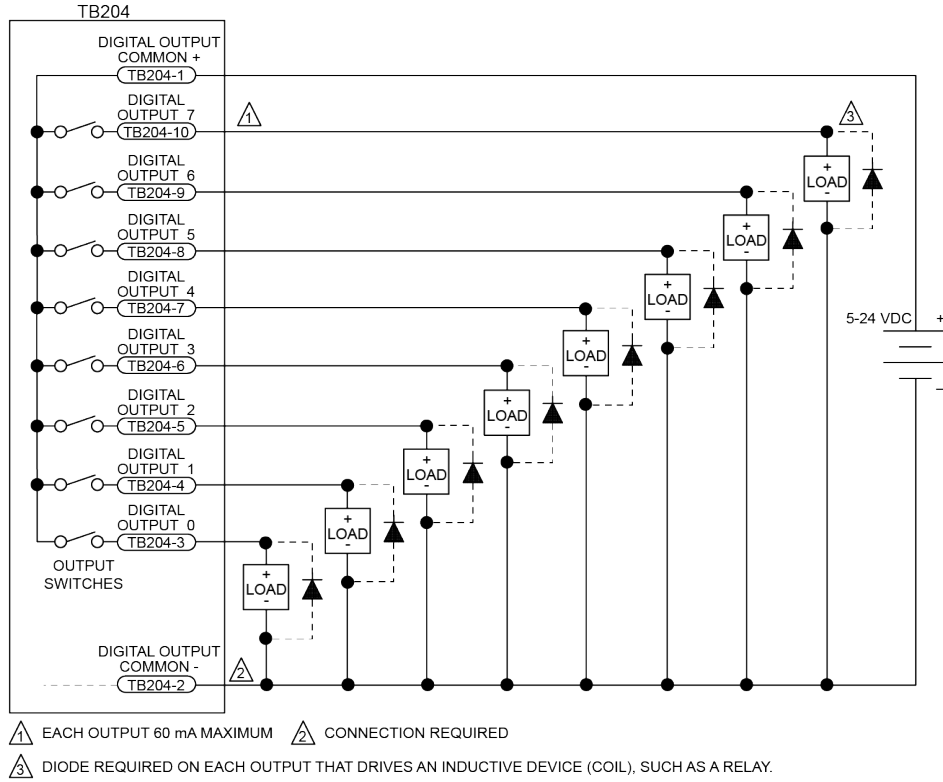

Figure 3-10: Digital Outputs Connected in Current Sourcing Mode

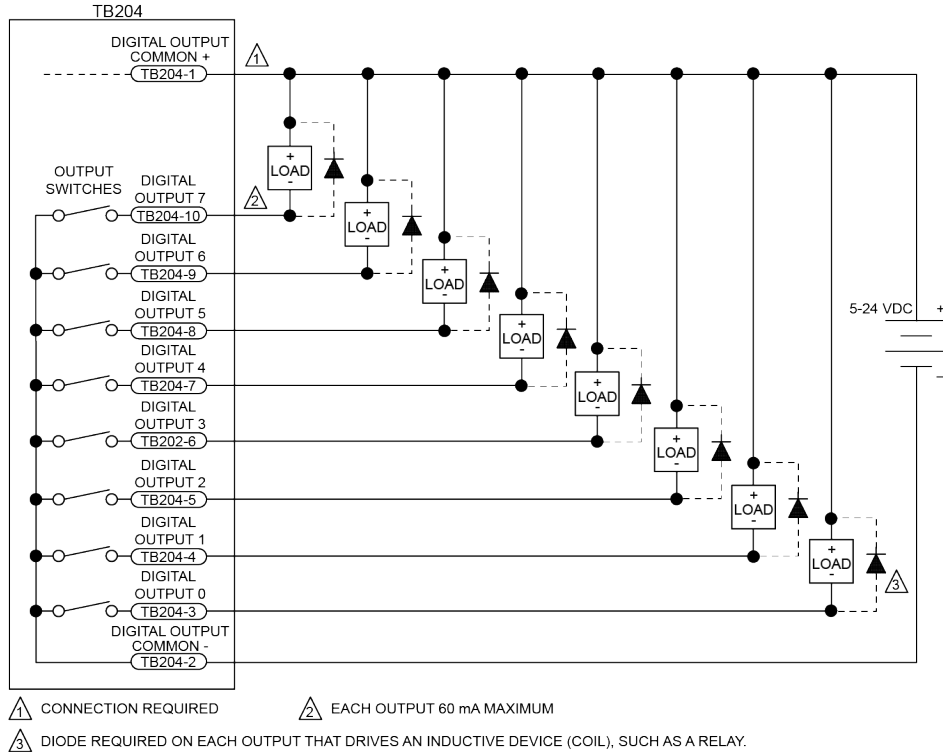

Figure 3-11: Digital Outputs Connected in Current Sinking Mode

3.6. Auxiliary Encoder Channel/PSO Output (J201)

The auxiliary encoder interface accepts an RS-422 differential quadrature line driver signal. Invalid or missing signals will cause a feedback fault when the axis is enabled.

This encoder channel can be used as an input for master/slave operation (handwheel) or for dual feedback systems. The auxiliary encoder interface does not support analog encoders and cannot be used as an input for the -MXH or -MXU option.

The auxiliary encoder channel can also be used to echo the standard encoder signals or as the PSO output. Configuring the PSO hardware will automatically configure this encoder channel as an output (refer to [Section 3.6.1.](#)) and will remove the 180 ohm terminator resistors.

Table 3-17: Auxiliary Encoder Specifications

Specification	Value
Encoder Frequency	10 MHz maximum (25 nsec minimum edge separation)
x4 Quadrature Decoding	40 million counts/sec
MXH Interpolation Latency	~ 3.25 μ sec (analog input to quadrature output)

NOTE: Use the EncoderDivider parameter to configure the bi-directional encoder interface on the auxiliary I/O connector. The EncoderDivider parameter converts the auxiliary encoder interface to an output and defines a divisor for the encoder echo. Refer to the A3200 Help file for more information.

NOTE: You cannot echo the standard encoder signals on the ML with the -MXU option.

Table 3-18: Auxiliary Encoder Channel Pinout (J201)

Pin#	Description	In/Out/Bi	Connector
1	Auxiliary RS-422 Marker Pulse - / PSO Output ⁽¹⁾	Bidirectional	
2	Auxiliary RS-422 Encoder Cosine +	Bidirectional	
3	Auxiliary RS-422 Encoder Cosine -	Bidirectional	
4	Auxiliary RS-422 Encoder Sine +	Bidirectional	
5	Encoder Cable Shield	N/A	
6	Auxiliary RS-422 Marker Pulse + / PSO Output ⁽¹⁾	Bidirectional	
7	Encoder +5 Volt Power	Output	
8	Encoder Power Common	N/A	
9	Auxiliary RS-422 Encoder Sine -	Bidirectional	

(1) For PSO, see [Section 3.6.1.](#)

Table 3-19: Mating Connector Part Numbers for the Auxiliary Encoder Connector (J201)

J201 Adapter Cable Assembly	Aerotech P.N.	Third Party P.N.
9 Pin Standard D-style	C20931	N/A
25 Pin Standard D-style	C20932	N/A
Flying Leads	ECZ01343	Molex 83421-9042

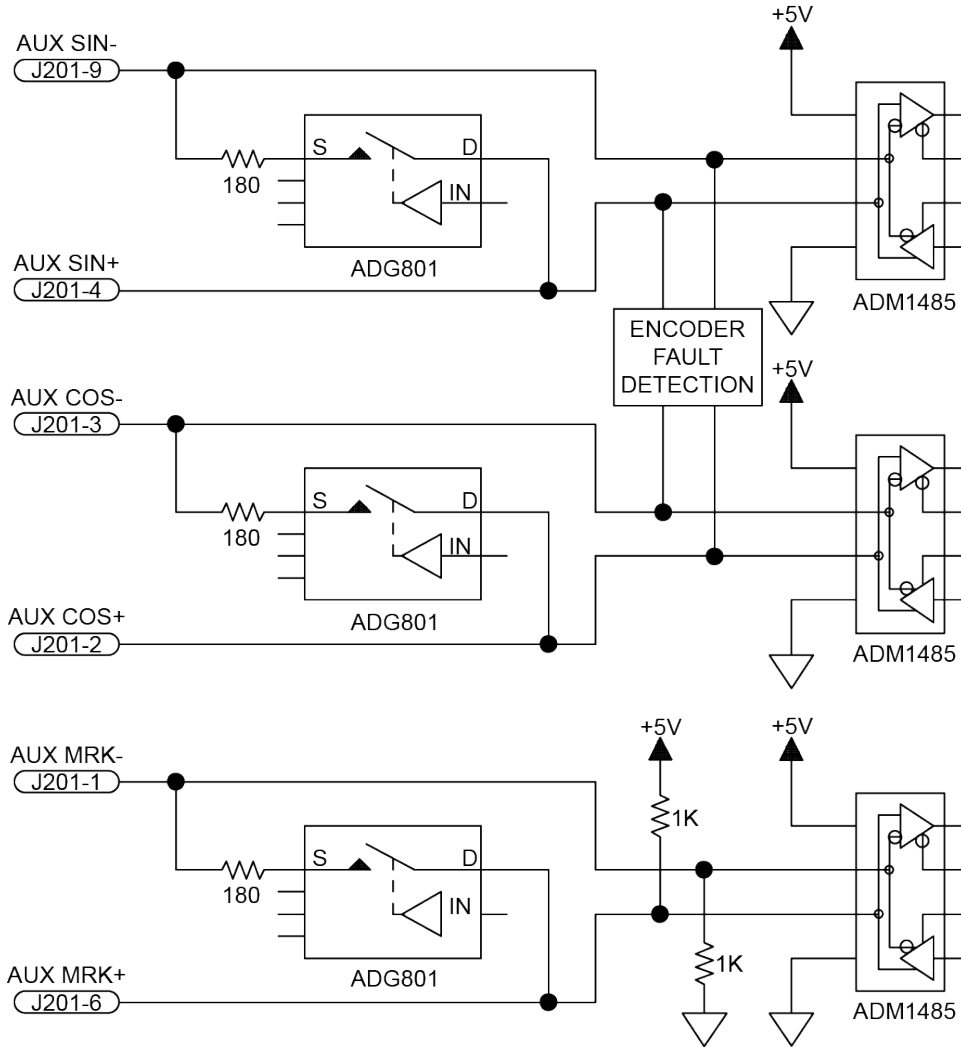

Figure 3-12: Auxiliary Encoder Channel (J201)

3.6.1. Position Synchronized Output (PSO)/Laser Firing (J201)

The PSO can be programmed to generate an output synchronized to the feedback position and is typically used to fire a laser or sequence an external device. Trigger signals may be derived from a feedback channel or a software trigger. The position synchronized output pulse is generated using high-speed hardware, allowing minimal latency between the trigger condition and the output.

The PSO output is available on the dual-function AUX Marker/PSO signal lines. The auxiliary marker must be configured as an output using the PSOOUTPUT CONTROL command. Refer to the Help File for more information.

An RS-422 line receiver or opto-isolator is recommended, especially when using long cable lengths in noisy environments or when high frequency pulse transmission is required. It is best to locate the line receiver or opto-isolator close to the receiving electronics.

Use Aerotech's BB-MP wiring module to connect two drives for dual-axis PSO firing. The BB-MP module will convert the AUX MARKER / PSO differential signal into other formats if required. It provides opto-isolation, higher voltage operation, and can be used in sourcing or sinking output configurations. It also simplifies the connection of encoder signals between axes that is required for two axis PSO operation. Refer to the BB-MP manual for interconnection information.

Table 3-20: PSO Specifications

Specification		Value
Maximum Input Tracking Rate ⁽¹⁾	Single-Axis Tracking	16.6 MHz
	Dual-Axis Tracking	8.33 MHz
Maximum Quadrature Encoder Output Frequency	Standard Feedback	40 MHz
	-MXH Feedback	25 MHz
Maximum PSO Output (Fire) Frequency ⁽²⁾		12.5 MHz
Firing Latency ⁽³⁾	Single-Axis Tracking	160 nsec
	Dual-Axis Tracking	220 nsec
1. Signals in excess of this rate will cause a loss of PSO accuracy. 2. The optocoupler that you use on the output might have an effect on this rate. 3. MXH encoder multiplier options have an additional latency of ~3.25 microseconds between the measurement position and the update of the PSO hardware.		

NOTE: When using the MRK± signals with single-ended systems, **do not** connect MRK+ or MRK- to GROUND (GND).

NOTE: The PSO feature is **not** compatible with the -MXU option. The PSO feature operates with the -MXH option and with square wave encoders.

Software controlled PSO pre-scalars may be used to limit the data rate of each encoder being tracked without affecting the servo loop data rate.

Table 3-21: PSO Output Pin Assignment (J201)

Pin#	Description	In/Out/Bi
1	Auxiliary RS-422 Marker Pulse - / PSO Output	Bidirectional
6	Auxiliary RS-422 Marker Pulse + / PSO Output	Bidirectional
8	Encoder Power Common	N/A

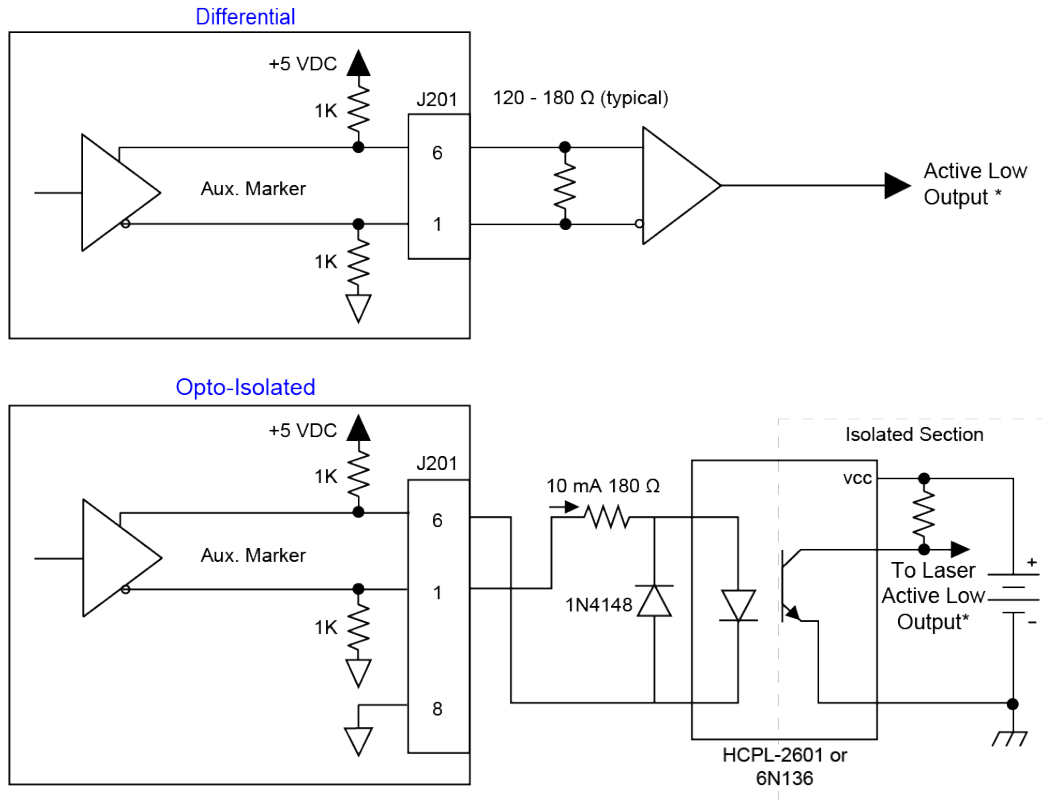

* Active low output shown. Opposite polarity available by reversing connections to Pins 1 and 6.

Figure 3-13: PSO Interface

This page intentionally left blank.

Chapter 4: Standard Interconnection Cables

NOTE: A complete list of Aerotech cables can be found on the website at <http://www.aerotechmotioncontrol.com/manuals/index.aspx>.

Table 4-1: Standard Interconnection Cables

Cable Part #	Description
Joystick	See Section 4.1 .
ECZ01231	BBA32 Interconnect Cable

4.1. Joystick Interface

Aerotech joysticks JI (NEMA12 (IP54) rated) and JBV are powered from 5V and have a nominal 2.5V output in the center detent position. Three buttons are used to select axis pairs and speed ranges. An optional interlock signal is used to indicate to the controller that the joystick is present. Joystick control will not activate unless the joystick is in the center location. Third party devices can be used provided they produce a symmetric output voltage within the range of -10V to +10V.

The following drawings illustrate how to connect a single- or two-axis joystick . For cable details refer to [Table 4-2](#). Refer to the A3200 Help file for programming information about how to change joystick parameters.

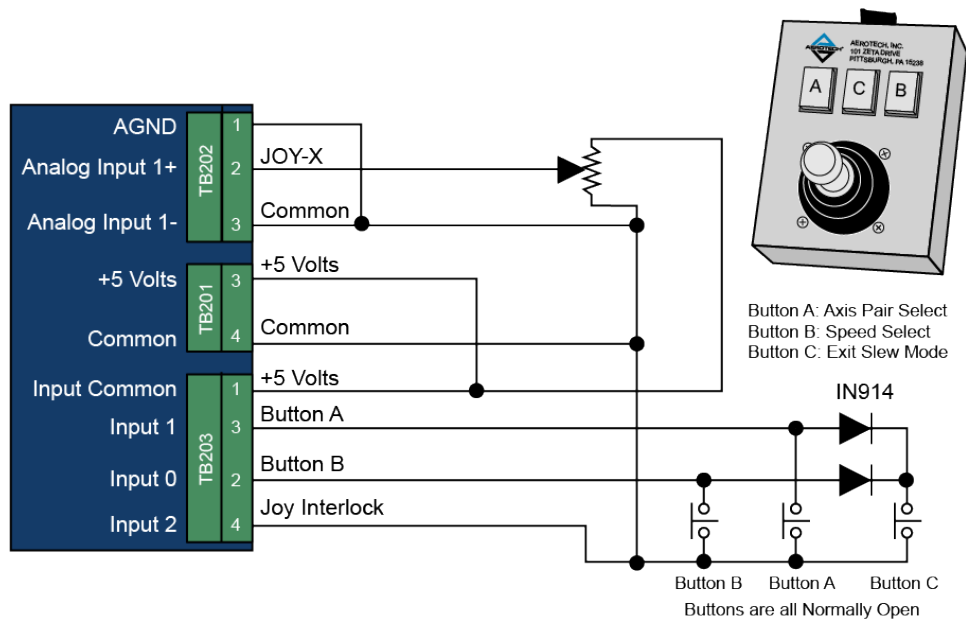

Figure 4-1: Single Axis Joystick Interface

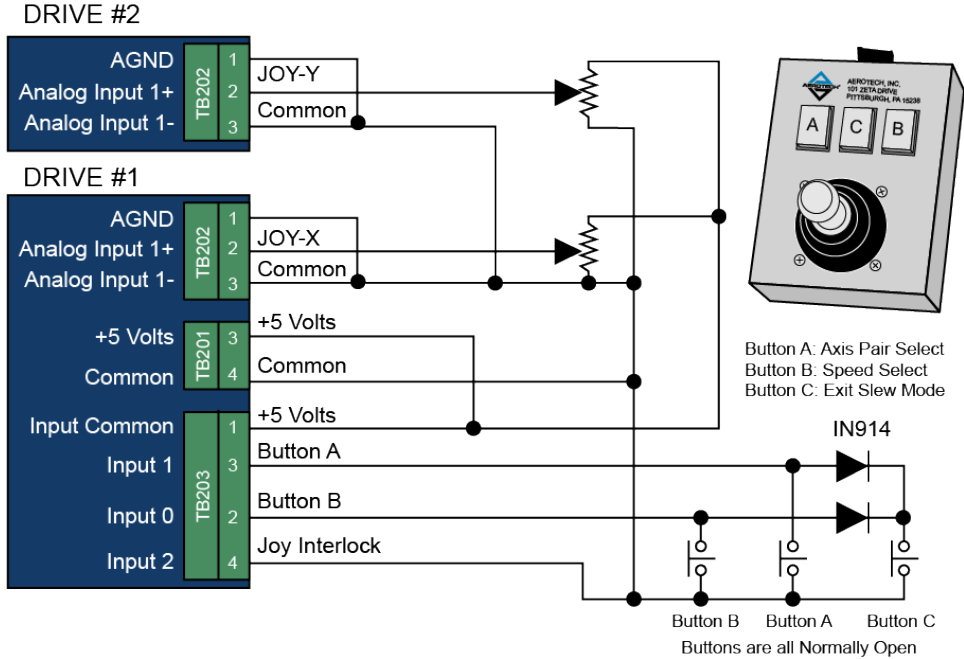

Figure 4-2: Two Axis Joystick Interface

Table 4-2: Joystick Cable Part Numbers

Part #	Cable Description	UPC #
C22751-XX	JSXT-FLY-15DU-MAX300DM NDRIVEMP/ML SINGLE AXIS	630B2275-1
C22752-XX	JSXT-FLY-FLY-15DU-MAX300DM NDRIVEMP/ML DUAL AXIS	630B2275-2

4.2. Handwheel Interface

A handwheel (such as the Aerotech HW-xxx-xx) can be used to manually control axis position. The handwheel must provide 5V differential quadrature signals to the Ndrive ML.

A handwheel can be connected to the Aux I/O as shown in [Figure 4-3](#).

NOTE: See the A3200 Help file for information on enabling the handwheel.

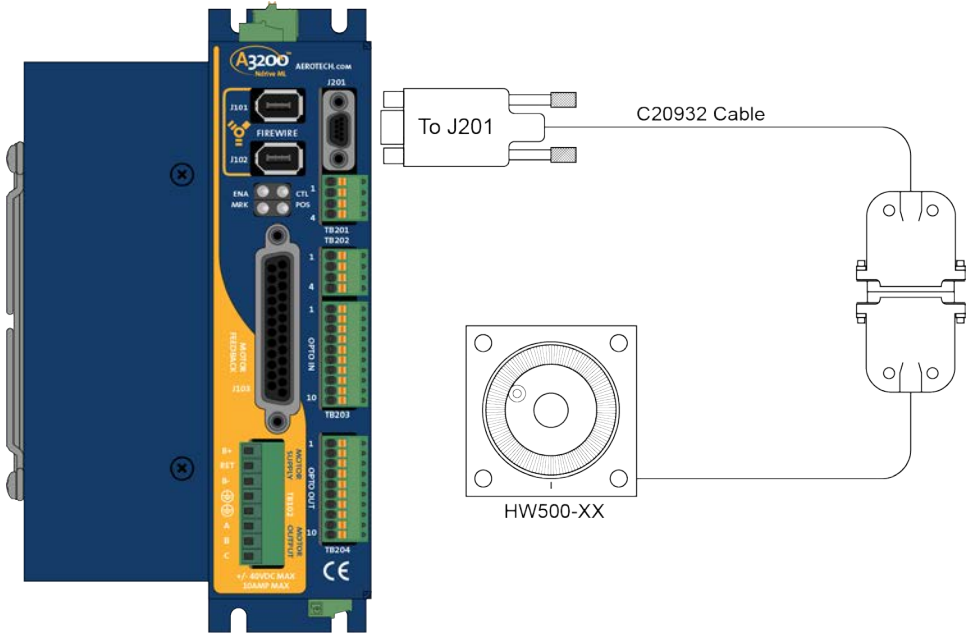

Figure 4-3: Handwheel Interconnection (to Aux I/O)

Chapter 5: Maintenance

Except for S1, the Ndrive ML does not have any user-configurable switches or jumpers.



DANGER: Always disconnect the Mains power connection before opening the Ndrive ML chassis.



DANGER: Before performing any tests, be aware of lethal voltages inside the controller and at the input and output power connections. A qualified service technician or electrician should perform these tests.

Table 5-1: LED Description

LED	Description
ENB/FLT	Turns green to indicate that the axis is enabled. Turns red to indicate a fault condition. The ENB/FLT LED will flash between RED and GREEN if the drive is enabled and in a fault condition.
MARKER	Turns green to indicate that the marker input is high.
CTL*	Turns green when power is applied.
POS	Turns green to indicate that the axis is in position.
* If the power light flashes continuously and the unit does not operate, there is too much current draw from the 5V power supply or the control supply voltage level is low.	

5.1. Preventative Maintenance

The Ndrive ML and external wiring should be inspected monthly. Inspections may be required at more frequent intervals, depending on the environment and use of the system.



DANGER: To minimize the possibility of bodily injury or death, disconnect all electrical power prior to performing any maintenance or making adjustments to the equipment.

Table 5-2: Preventative Maintenance

Check	Action to be Taken
Visually Check chassis for loose or damaged parts / hardware. Note: Internal inspection is not required.	Parts should be repaired as required. If internal damage is suspected, these parts should be checked and repairs made if necessary.
Inspect cooling vents.	Remove any accumulated material from vents.
Check for fluids or electrically conductive material exposure.	Any fluids or electrically conductive material must not be permitted to enter the Ndrive ML.
Visually inspect all cables and connections.	Tighten or re-secure any loose connections. Replace worn or frayed cables. Replace broken connectors.

Cleaning

The Ndrive ML chassis can be wiped with a clean, dry, soft cloth. The cloth may be slightly moistened if required with water or isopropyl alcohol to aid in cleaning if necessary. In this case, be careful not to allow moisture to enter the Ndrive ML or onto exposed connectors / components. Fluids and sprays are not recommended because of the chance for internal contamination, which may result in electrical shorts and/or corrosion. The electrical power must be disconnected from the Ndrive ML while cleaning. Do not allow cleaning substances or other fluids to enter the Ndrive ML or to get on to any of the connectors. Avoid cleaning labels to prevent removing the label information.

Appendix A: Warranty and Field Service

Aerotech, Inc. warrants its products to be free from harmful defects caused by faulty materials or poor workmanship for a minimum period of one year from date of shipment from Aerotech. Aerotech's liability is limited to replacing, repairing or issuing credit, at its option, for any products that are returned by the original purchaser during the warranty period. Aerotech makes no warranty that its products are fit for the use or purpose to which they may be put by the buyer, whether or not such use or purpose has been disclosed to Aerotech in specifications or drawings previously or subsequently provided, or whether or not Aerotech's products are specifically designed and/or manufactured for buyer's use or purpose. Aerotech's liability on any claim for loss or damage arising out of the sale, resale, or use of any of its products shall in no event exceed the selling price of the unit.

THE EXPRESS WARRANTY SET FORTH HEREIN IS IN LIEU OF AND EXCLUDES ALL OTHER WARRANTIES, EXPRESSED OR IMPLIED, BY OPERATION OF LAW OR OTHERWISE. IN NO EVENT SHALL AEROTECH BE LIABLE FOR CONSEQUENTIAL OR SPECIAL DAMAGES.

Return Products Procedure

Claims for shipment damage (evident or concealed) must be filed with the carrier by the buyer. Aerotech must be notified within thirty (30) days of shipment of incorrect material. No product may be returned, whether in warranty or out of warranty, without first obtaining approval from Aerotech. No credit will be given nor repairs made for products returned without such approval. A "Return Materials Authorization (RMA)" number must accompany any returned product(s). The RMA number may be obtained by calling an Aerotech service center or by submitting the appropriate request available on our website (www.aerotech.com). Products must be returned, prepaid, to an Aerotech service center (no C.O.D. or Collect Freight accepted). The status of any product returned later than thirty (30) days after the issuance of a return authorization number will be subject to review.

Visit <https://www.aerotech.com/global-technical-support.aspx> for the location of your nearest Aerotech Service center.

Returned Product Warranty Determination

After Aerotech's examination, warranty or out-of-warranty status will be determined. If upon Aerotech's examination a warranted defect exists, then the product(s) will be repaired at no charge and shipped, prepaid, back to the buyer. If the buyer desires an expedited method of return, the product(s) will be shipped collect. Warranty repairs do not extend the original warranty period.

Fixed Fee Repairs - Products having fixed-fee pricing will require a valid purchase order or credit card particulars before any service work can begin.

All Other Repairs - After Aerotech's evaluation, the buyer shall be notified of the repair cost. At such time the buyer must issue a valid purchase order to cover the cost of the repair and freight, or authorize the product(s) to be shipped back as is, at the buyer's expense. Failure to obtain a purchase order number or approval within thirty (30) days of notification will result in the product(s) being returned as is, at the buyer's expense.

Repair work is warranted for ninety (90) days from date of shipment. Replacement components are warranted for one year from date of shipment.

Rush Service

At times, the buyer may desire to expedite a repair. Regardless of warranty or out-of-warranty status, the buyer must issue a valid purchase order to cover the added rush service cost. Rush service is subject to Aerotech's approval.

On-site Warranty Repair

If an Aerotech product cannot be made functional by telephone assistance or by sending and having the customer install replacement parts, and cannot be returned to the Aerotech service center for repair, and if Aerotech determines the problem could be warranty-related, then the following policy applies:

Aerotech will provide an on-site Field Service Representative in a reasonable amount of time, provided that the customer issues a valid purchase order to Aerotech covering all transportation and subsistence costs. For warranty field repairs, the customer will not be charged for the cost of labor and material. If service is rendered at times other than normal work periods, then special rates apply.

If during the on-site repair it is determined the problem is not warranty related, then the terms and conditions stated in the following "On-Site Non-Warranty Repair" section apply.

On-site Non-Warranty Repair

If any Aerotech product cannot be made functional by telephone assistance or purchased replacement parts, and cannot be returned to the Aerotech service center for repair, then the following field service policy applies:

Aerotech will provide an on-site Field Service Representative in a reasonable amount of time, provided that the customer issues a valid purchase order to Aerotech covering all transportation and subsistence costs and the prevailing labor cost, including travel time, necessary to complete the repair.

Service Locations

<http://www.aerotech.com/contact-sales.aspx?mapState=showMap>

USA, CANADA, MEXICO	CHINA	GERMANY
Aerotech, Inc. Global Headquarters Phone: +1-412-967-6440 Fax: +1-412-967-6870	Aerotech China Full-Service Subsidiary Phone: +86 (21) 5508 6731	Aerotech Germany Full-Service Subsidiary Phone: +49 (0)911 967 9370 Fax: +49 (0)911 967 93720
TAIWAN	UNITED KINGDOM	
Aerotech Taiwan Full-Service Subsidiary Phone: +886 (0)2 8751 6690	Aerotech United Kingdom Full-Service Subsidiary Phone: +44 (0)1256 855055 Fax: +44 (0)1256 855649	

Have your customer order number ready before calling.

Appendix B: Revision History

Revision	Description
1.11.00	Updated: Section 2.2.3. External Power Supply Options
1.10.00	The following sections have been updated: <ul style="list-style-type: none">• EU Declaration of Conformity• Agency Approvals• Section 3.2. Brake Relay Connector (TB201)• Section 3.6.1. Position Synchronized Output (PSO)/Laser Firing (J201)
1.09.00	Updated: Agency Approvals
1.08.00	The following sections have been updated: <ul style="list-style-type: none">• Section 2.4.3. Thermistor Interface (J103)• Section 2.5. Emergency Stop Sense Input (TB101)
1.07.00	Revision changes have been archived. If you need a copy of this revision, contact Aerotech Global Technical Support.
1.06.00	
1.05.00	
1.04.00	
1.03.00	
1.02.00	
1.01.00	
1.00.00	

This page intentionally left blank.

Index

-		Brushless Motor Phasing Goal	36
		C	
-I/O Expansion Board	61	Check chassis for loose or damaged parts / hardware	84
-IO Option Board	61	Check for fluids or electrically conductive material exposure	84
-IO Options	61	Cleaning	84
-MXH Option	43-44	Communication Channel Settings	25
-MXU Option	43-44	Continuous Output Current specifications	20
	2	Control and Motor Power Wiring using a TM3 Transformer	30
2011/65/EU	9	Control Supply Connections	27
2014/35/EU	9	Control Supply DC Input Wiring	27-28
	A	Control Supply Mating Connector	27
Altitude	23	Control Supply specifications	20
Ambient Temperature	23		
Analog Encoder Phasing Reference Diagram	44	D	
Analog Encoder Specifications	44	DC Brush Motor Connections	37
Analog Input (I/O Board)	67	DC Brush Motor Phasing	38
Analog Input 0 (J103)	55	Declaration of Conformity	9
Analog Input 1 Connector	67	Device Number (Switch S1)	25
Analog Input Connector Pin Assignment	55	Digital Input Connector Pin Assignment	68
Analog Inputs Connector Pin Assignment	67	Digital Input Specifications	68
Analog Output 1 Connector Pin Assignment	65-66	Digital Inputs	68-69
Auxiliary Encoder Channel	75	Digital Output Connector Pin Assignment	71
Auxiliary Encoder Channel Pin Assignment	74,76	Digital Outputs	71
	B	Digital Outputs (-IO Board)	72
Brake Connected to J207	64	dimensions	22
Brake Connected to TB20	64	Din Rail Clip Mounting Hardware	29
Brake Output	54	Drive and Software Compatibility	19
Brake Output Connector Pin Assignment	63		
Brake Output Pin Assignment	54	E	
Brake Power Supply	63	Electrical Specifications	20
Brushless Motor Connections	34	Emergency Stop Sense Input	56
Brushless Motor Phasing	34	EN 61800-3	9
		Encoder and Hall Signal Diagnostics	35

P			
PC Configuration and Operation Information	59	TB201	62-64
Peak Output Current specifications	20	TB202	65-67
Pollution	23	TB203	68
Position Feedback in the Diagnostic Display	47	TB204	71
Position Synchronized Output (PSO)/Laser Firing	76	Technical Support	2
Power Amplifier Bandwidth specifications	20	Thermistor Interface	49
Powered Motor Phasing	35	Thermistor Interface Input	49
Preventative Maintenance	84	Two Axis Joystick Interface	81
Protective Features	20	Typical Emergency Stop Circuit	57
PSO Interface	77	Typical ESTOP Interface	57
PSO Output Sources	76	U	
Q		unit separation	22
Quick Installation Guide	13	unit weight	22
R		Unpowered Motor and Feedback Phasing	36
Relay Specifications	63	Use	23
RS-422 Line Driver Encoder (Standard)	43	User Common Connector Pin Assignment	62
S		User Power	62
S1 (Communication Channel Setting)	25	User Power Supply specifications	20
Screws		W	
Din Rail Clip	29	Wire Colors for Supplied Cables	34,37,39
Single Axis Joystick Interface	80	Wiring	
solid state brake control relay	63	Control Supply	27-28
Standard Features	16		
Stepper Motor Connections	39		
Stepper Motor Phasing	40		
Support	2		
Switch S1 (Communication Channel Setting)	25		
T			
TB101	56		
TB102	28,33		
TB103	27		

This page intentionally left blank.