

TM3 Hardware Manual

Revision: 2.02.00

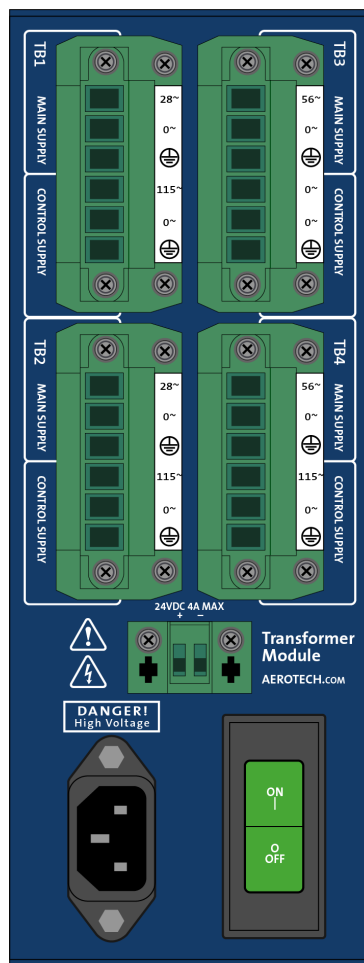

Global Technical Support

Go to www.aerotech.com/global-technical-support for information and support about your Aerotech, Inc. products. The website supplies software, product manuals, Help files, training schedules, and PC-to-PC remote technical support. If necessary, you can complete Product Return (RMA) forms and get information about repairs and spare or replacement parts. To get help immediately, contact a service office or your sales representative. Include your customer order number in your email or have it available before you call.

United States (World Headquarters)	
Email: Support@aerotech.com Phone: +1-412-967-6440 Fax: +1-412-967-6870	101 Zeta Drive Pittsburgh, PA 15238-2811 www.aerotech.com
United Kingdom	Japan
Email: Support@aerotech.com Phone: +44 (0)1256 855055 Fax: +44 (0)1256 855649	Email: Support@aerotech.com Phone: +81 (0)50 5830 6814 Fax: +81 (0)43 306 3773
Germany	China
Email: Support@aerotech.com Phone: +49 (0)911 967 9370 Fax: +49 (0)911 967 93720	Email: Support@aerotech.com Phone: +86 (21) 5508 6731
France	Taiwan
Email: Support@aerotech.com Phone: +33 2 37 21 87 65	Email: Support@aerotech.com Phone: +886 (0)2 8751 6690

This manual contains proprietary information and may not be reproduced, disclosed, or used in whole or in part without the express written permission of Aerotech, Inc. Product names mentioned herein are used for identification purposes only and may be trademarks of their respective companies.

Copyright © 2005-2019, Aerotech, Inc., All rights reserved.

Aerotech Worldwide

United States ■ France ■ Germany ■ United Kingdom
China ■ Japan ■ Taiwan



Table of Contents

- TM3 Hardware Manual** **1**
 - Table of Contents 3
 - List of Figures 4
 - List of Tables 5
 - EU Declaration of Conformity 7
 - Agency Approvals 8
 - Safety Procedure and Warnings 9

- Chapter 1: TM3 Transformer Module** **11**
 - 1.1. Electrical Specifications 13
 - 1.2. Installation and Mounting 14
 - 1.2.1. Handling and Transportation 14
 - 1.2.2. Installation 14
 - 1.2.3. Mechanical Specifications 14
 - 1.2.4. Environmental Specifications 16
 - 1.2.5. System Interconnection 17
 - 1.2.6. AC Power Input 25
 - 1.2.7. Power Output Connections (TB1-TB4) 25
 - 1.2.8. +24 VDC Output [PS24-1] 26
 - 1.2.9. Soft-Start Voltage Selector Overview 27
 - 1.3. Operation 28
 - 1.4. Maintenance 29
 - 1.4.1. Troubleshooting 30
 - 1.4.2. Fuse Replacement 30
 - 1.4.3. Preventative Maintenance 31

- Appendix A: Warranty and Field Service** **33**

- Appendix B: Revision History** **35**

- Index** **37**

List of Figures

Figure 1-1: TM3 Transformer Module 11

Figure 1-2: TM3 Dimensions15

Figure 1-3: System Interconnect Example (HPe) 17

Figure 1-4: System Interconnect Example (CP) 18

Figure 1-5: System Interconnect Example (MP) 19

Figure 1-6: System Interconnect Example (CL)20

Figure 1-7: System Interconnect Example (ML)21

Figure 1-8: System Interconnect Example (Nmark CLS)22

Figure 1-9: System Interconnect Example (GL4) 23

Figure 1-10: System Interconnect Example (XL4s)24

Figure 1-11: Soft-Start / Voltage Select Board 27

List of Tables

Table 1-1: TM3 Configurations and Options 12
Table 1-2: Electrical Specifications 13
Table 1-3: Mechanical Specifications 15
Table 1-4: Power Output Connections (TB1-4) 25
Table 1-5: Power Output Mating Connector 25
Table 1-6: +24 VDC Output Connections 26
Table 1-7: +24 VDC Output Mating Connector 26
Table 1-8: Soft-Start/Voltage Selector Switch Settings 27
Table 1-9: Symptoms, Causes, and Solutions 30
Table 1-10: TM3 Fuse Replacement Part Numbers 30
Table 1-11: Preventative Maintenance 31

This page intentionally left blank.

EU Declaration of Conformity

Manufacturer Aerotech, Inc.
Address 101 Zeta Drive
 Pittsburgh, PA 15238-2811
 USA
Product TM3
Model/Types All

This is to certify that the aforementioned product is in accordance with the applicable requirements of the following Directive(s):

2014/35/EU	Low Voltage Directive
2011/65/EU	RoHS 2 Directive

and has been designed to be in conformity with the applicable requirements of the following Standard(s) when installed and used in accordance with the manufacturer’s supplied installation instructions.

EN 61010-1:2010	Safety Requirements for Electrical Equipment
-----------------	----------------------------------------------

Authorized Representative: Simon Smith, European Director
Address: Aerotech Ltd
 The Old Brick Kiln, Ramsdell, Tadley
 Hampshire RG26 5PR
 UK

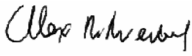
Name  / Alex Weibel
Position Engineer Verifying Compliance
Location Pittsburgh, PA
Date 5/22/2019



Agency Approvals

Aerotech, Inc. Model TM3 Transformer Modules have been tested and found to be in accordance to the following listed Agency Approvals:

Approval / Certification:	CUS NRTL
Approving Agency:	TUV SUD America Inc.
Certificate #:	U8 068995 0026 Rev. 00
Standards:	UL 61010-1:2012; CAN/CSA-C22.2 No. 61010-1:2012

Visit <https://www.tuev-sued.de/product-testing/certificates> to view Aerotech's TÜV SÜD certificates. Type the certificate number listed above in the search bar or type "Aerotech" for a list of all Aerotech certificates.

Safety Procedure and Warnings

This manual tells you how to carefully and correctly use and operate the TM3. Read all parts of this manual before you install or operate the TM3 or before you do maintenance to your system. To prevent injury to you and damage to the equipment, obey the precautions in this manual. The precautions that follow apply when you see a Danger or Warning symbol in this manual. If you do not obey these precautions, injury to you or damage to the equipment can occur. If you do not understand the information in this manual, contact Aerotech Global Technical Support.

This product has been designed for light industrial manufacturing or laboratory environments. The protection provided by the equipment could be impaired if the product is used in a manner not specified by the manufacturer.

NOTE: Aerotech continually improves its product offerings; listed options may be superseded at any time. All drawings and illustrations are for reference only and were complete and accurate as of this manual's release. Refer to www.aerotech.com for the most up-to-date information.



WARNING: To minimize the possibility of electrical shock, bodily injury or death the following precautions must be followed.

1. If the product is used in a manner not specified by the manufacturer, the protection provided by the product can be impaired and result in damage, shock, injury, or death.
2. Moving parts can cause crushing or shearing injuries. Access to all stage and motor parts must be restricted while connected to a power source.
3. Cables can pose a tripping hazard. Securely mount and position all system cables to avoid potential hazards.
4. Do not expose this product to environments or conditions outside of the listed specifications. Exceeding environmental or operating specifications can cause damage to the equipment.
5. Operators must be trained before operating this equipment.
6. All service and maintenance must be performed by qualified personnel.



DANGER: This product contains potentially lethal voltages. To reduce the possibility of electrical shock, bodily injury, or death the following precautions must be followed.

1. Disconnect electrical power before servicing equipment.
2. Disconnect electrical power before performing any wiring.
3. Residual voltages greater than 60V may be present inside TM3 chassis for longer than 10 seconds after power has been disconnected.
4. To minimize the possibility of electrical shock and bodily injury, extreme care must be exercised when any electrical circuits are in use. Suitable precautions and protection must be provided to warn and prevent persons from making contact with live circuits.
5. Do not connect or disconnect any electrical components or connecting cables while connected to a power source.
6. All components must be properly grounded in accordance with local electrical safety requirements.
7. Operator safeguarding requirements must be addressed during final integration of the product.

This page intentionally left blank.

Chapter 1: TM3 Transformer Module

The TM3 transformer module provides and distributes isolated AC and/or DC bus supply voltages for up to four Aerotech controllers. It is configured at the factory to provide 28 VAC, 56 VAC, 40 VDC, 80 VDC or a combination of these voltages with a maximum transformer output power capability of 300 watts.

The TM3 also provides Control Supply outputs for powering the control power inputs of up to four Aerotech products and a 24 VDC power supply that provides the user with 24 VDC output with a current capacity of up to 4 A (up to 1 A on TM3s purchased before April 2016). Other features of the TM3 include a soft-start circuit to limit inrush current and a voltage selector that can be configured for AC input voltages of 100 VAC, 115 VAC, 200 VAC, or 230 VAC.

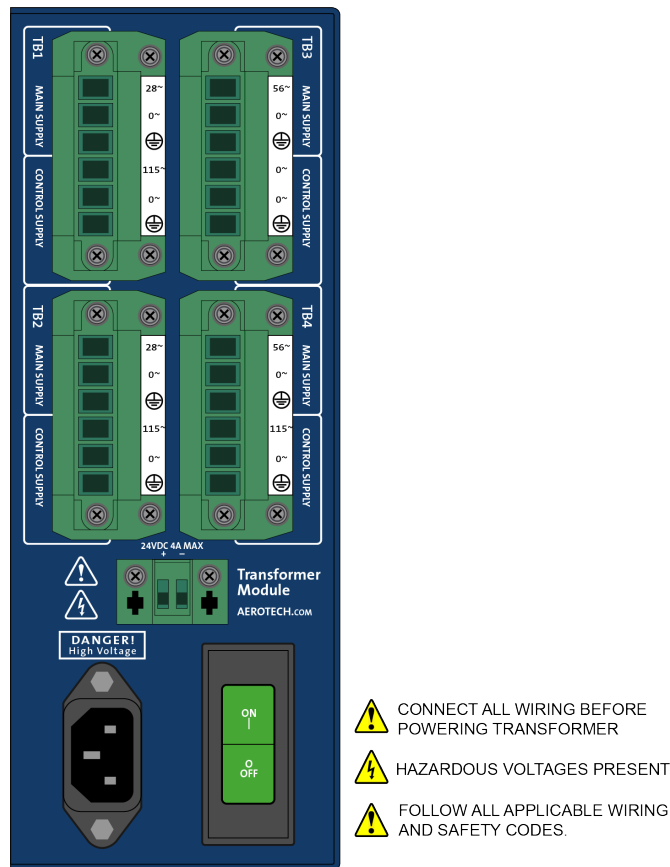

Figure 1-1: TM3 Transformer Module

The TM3 is built according to the configuration and options selected when the TM3 was ordered.

Table 1-1: TM3 Configurations and Options

AC Power Input (factory configured)			
-A	115 VAC	-C	100 VAC
-B	230 VAC	-D	200 VAC
Bus Voltage 1 (Vbus1)		Bus Voltage 2 (Vbus2)	
56VAC	56 VAC (for 80 VDC bus)	56VAC	56 VAC (for 80 VDC bus)
28VAC	28 VAC (for 40 VDC bus)	28VAC	28 VAC (for 40 VDC bus)
56VAC CT	56 VAC center tap for Ensemble CL drives (for 40 VDC bus)	56VAC CT	56 VAC center tap for Ensemble CL drives (for 40 VDC bus)
80VDC	80 VDC (for input to MP drives)	80VDC	80 VDC (for input to MP drives)
40VDC	40 VDC (for input to MP drives)	40VDC	40 VDC (for input to MP drives)
-40B AUX AC	±40 VDC bus with AUX AC output. AUX AC voltage will be the same as the TM3 line voltage	-40B AUX AC	±40 VDC bus with AUX AC output. AUX AC voltage will be the same as the TM3 line voltage
Axis Split (Vbus1 Vbus2)			
2-2	Axis 1-2 outputs are Vbus1, Axis 3-4 outputs are Vbus2		
No Split	Axis 1-4 outputs are Vbus1 (Bus 2 = Bus 1)		
Power Supply (Required)			
PS24-1	24 VDC power supply; 4 A maximum		
Optional Brake Cable (Only selected when /PS24-1 is selected)			
C24-06	6 decimeter (2 ft) two conductor brake cable with flying leads		
C24-09	9 decimeter (3 ft) two conductor brake cable with flying leads		
C24-12	12 decimeter (4 ft) two conductor brake cable with flying leads		
C24-15	15 decimeter (5 ft) two conductor brake cable with flying leads		
C24-18	18 decimeter (6 ft) two conductor brake cable with flying leads		
Control & Main Supply Cables			
C1	Cable Axis 1	C3	Cable Axis 3
C2	Cable Axis 2	C4	Cable Axis 4
Cable Type			
-AB	Bus and Aux Power		
-AL	Bus and Aux Power for CLS		
-B	Bus only		
Standard Cable Lengths			
06	6 decimeter (2 ft)	15	15 decimeter (5 ft)
09	9 decimeter (3 ft)	18	18 decimeter (6 ft)
12	12 decimeter (4 ft)		
Line Cord Options			
England	English line cord	Australia	Australian line cord
Germany	German line cord	US-115 VAC	US-115 VAC line cord
Israel	Israeli line cord	US-230 VAC	US-230 VAC line cord
India	Indian line cord	NO-LINECORD	No line cord

1.1. Electrical Specifications

Electrical specifications for the TM3 are listed in [Table 1-2](#).

Table 1-2: Electrical Specifications

Transformer	Aerotech EAX01007 Transformer (standard)
AC Input Configurations	100 VAC, 115 VAC, 200 VAC or 230 VAC
Peak AC Input Inrush Current	32 Apk
Operating Frequency	50/60Hz
Maximum Continuous Transformer Output Power	300 Watts, Max. @ 20°C
Peak Transformer Output Power	400 Watts, Max. @ 20°C
Short Circuit / Over Current Protection	AC input breaker/switch 100/115 VAC 10 A, 200/230 VAC 5 A (Supplementary protection only)
	100 VAC / 115 VAC configurations contain 4 A Slow Blow fuse connected to transformer primary winding
	200 VAC / 230 VAC configurations contain 3 A Slow Blow fuse connected to transformer primary winding
Thermal Protection	Integral transformer thermal switch is normally closed. Thermal switch opens when internal temperature of transformer reaches 110°C.
Secondary Winding Configuration	8 VAC (10 VDC Bus)
	15 VAC (20 VDC Bus)
	21 VAC (30 VDC Bus)
	28 VAC (40 VDC Bus)
	56 VAC (80 VDC Bus)
+24 VDC Output	4 A maximum for the user

1.2. Installation and Mounting

Installation and mounting information for the TM3 is provided in the following sections. Additional information is also provided in component manuals and other supplied drawings.



WARNING: Allow all system components to adjust to room temperature before installing. Do not install or apply power to system components if there is condensed moisture on components.



WARNING: All system components must be mounted securely before connecting cables and applying power.

1.2.1. Handling and Transportation

The Aerotech TM3 transformer module can be easily handled by firmly grasping the TM3 chassis itself. Be sure to grip the chassis firmly because the finish on the TM3 can be slippery. Do not attempt to hold or transport the TM3 by grasping onto cables or other hardware. When transporting the TM3 transformer module, it should be placed into a protective plastic bag and then into a box containing an appropriate packing material.

1.2.2. Installation

The Aerotech TM3 transformer module must be installed inside a rack on enclosure. Sufficient space (25 mm (1 inch) minimum) must be provided around the TM3 to allow for sufficient air circulation. Fan cooling is recommended with the airflow directed towards the vents. Allow at least a 100 mm (4 inch) minimum from the front cover for cable and connector clearance.

1.2.3. Mechanical Specifications

The outline dimensions for the TM3 transformer module are shown in [Figure 1-2](#). Mechanical specifications for TM3 are listed in [Table 1-3](#).

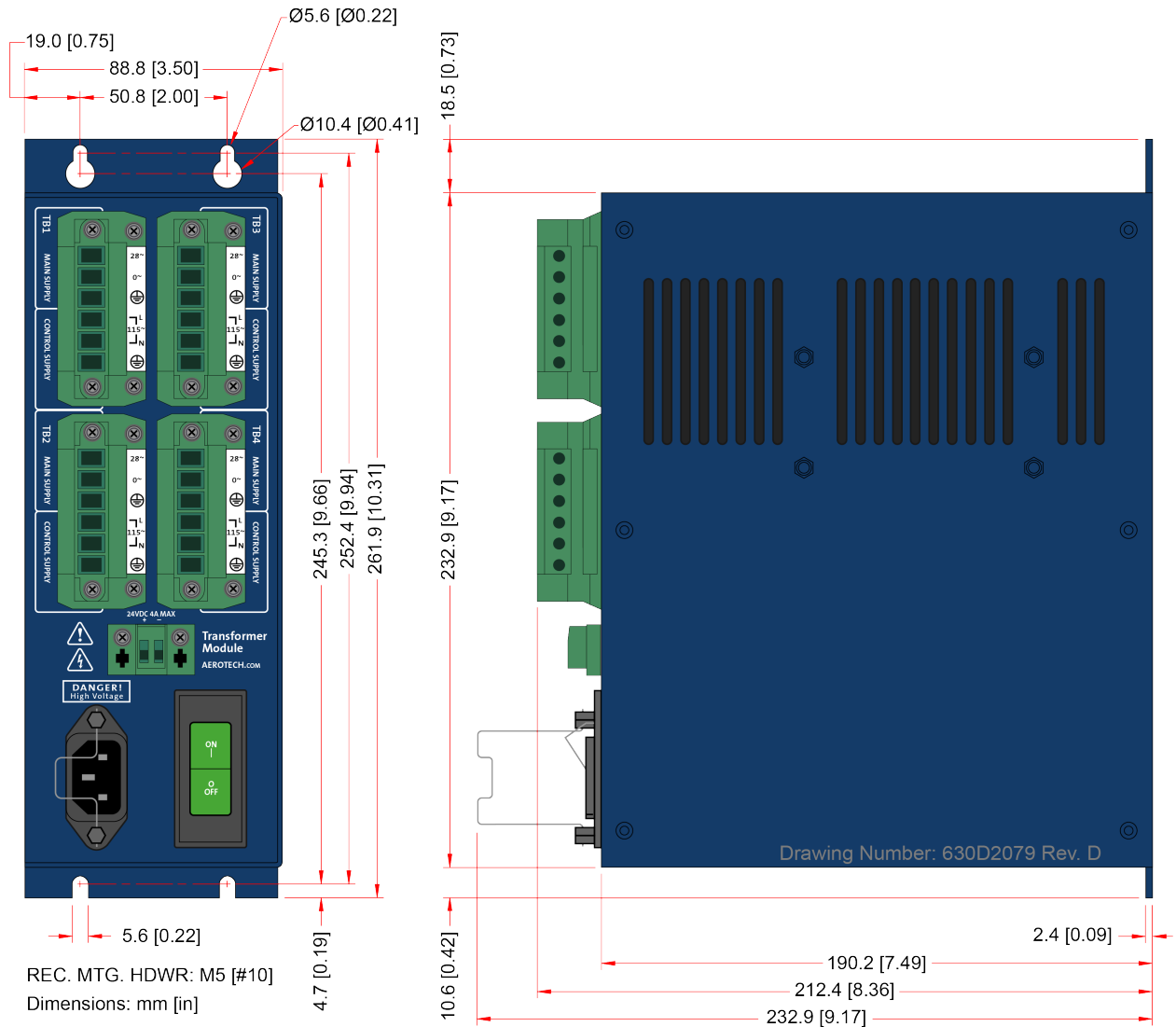

Figure 1-2: TM3 Dimensions

Table 1-3: Mechanical Specifications

Weight	5.72 kg (12.6 lbs)
Mounting Requirements	Rack or Enclosure mounting is required

1.2.4. Environmental Specifications

Temperature:	Ambient Operating: 5° - 40°C (41° - 104°F) Storage: -20° - 70°C (-4° - 158°F)
Humidity:	Maximum relative humidity is 80% for temperatures up to 31°C. Decreasing linearly to 50% relative humidity at 40°C. Non condensing.
Altitude:	Up to 2000 m
Pollution:	Pollution degree 2 (normally only non conductive pollution)
Use:	Indoor use only

1.2.5. System Interconnection

System interconnection examples are shown below but cables can be purchased from Aerotech.

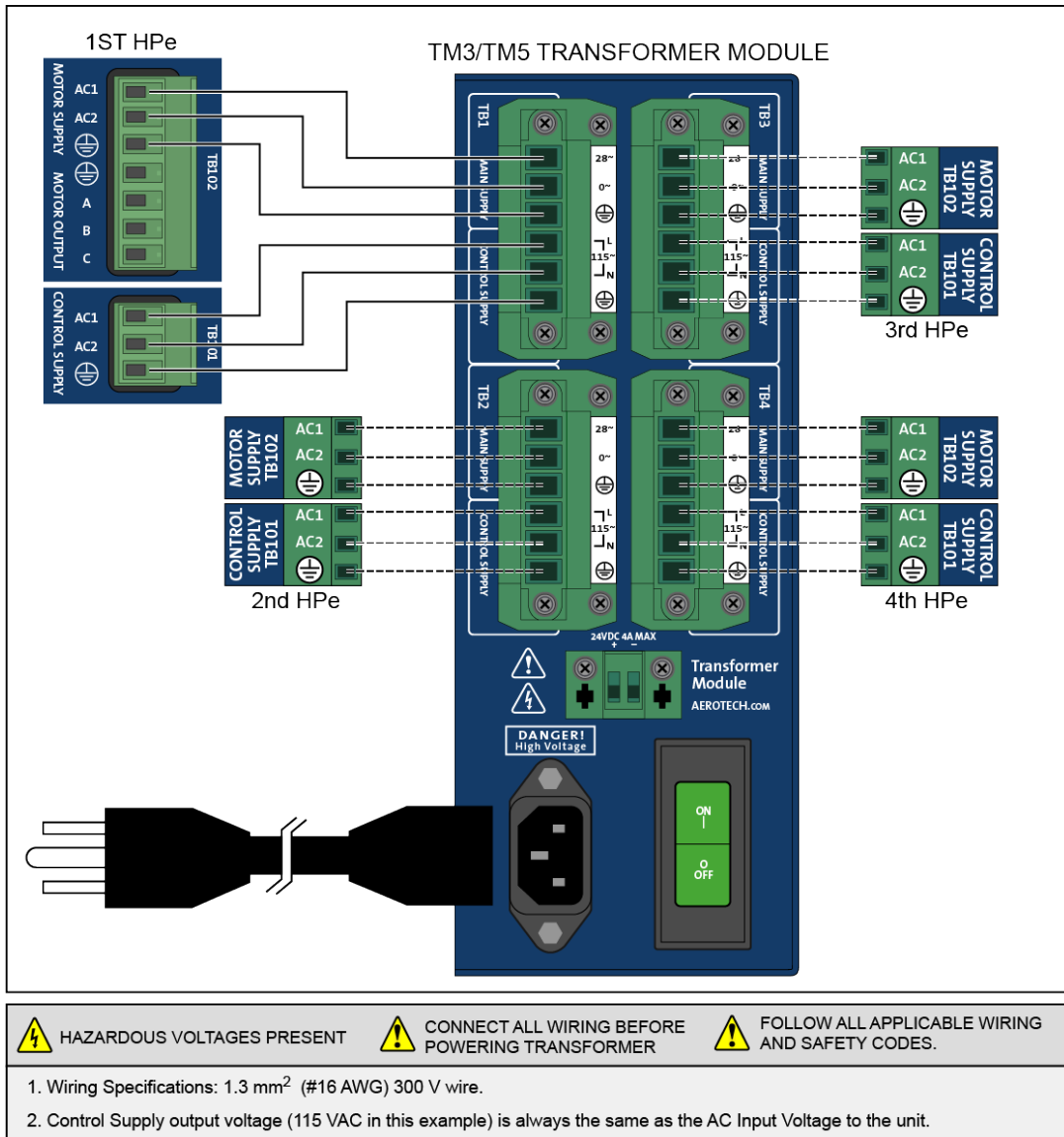

Figure 1-3: System Interconnect Example (HPe)

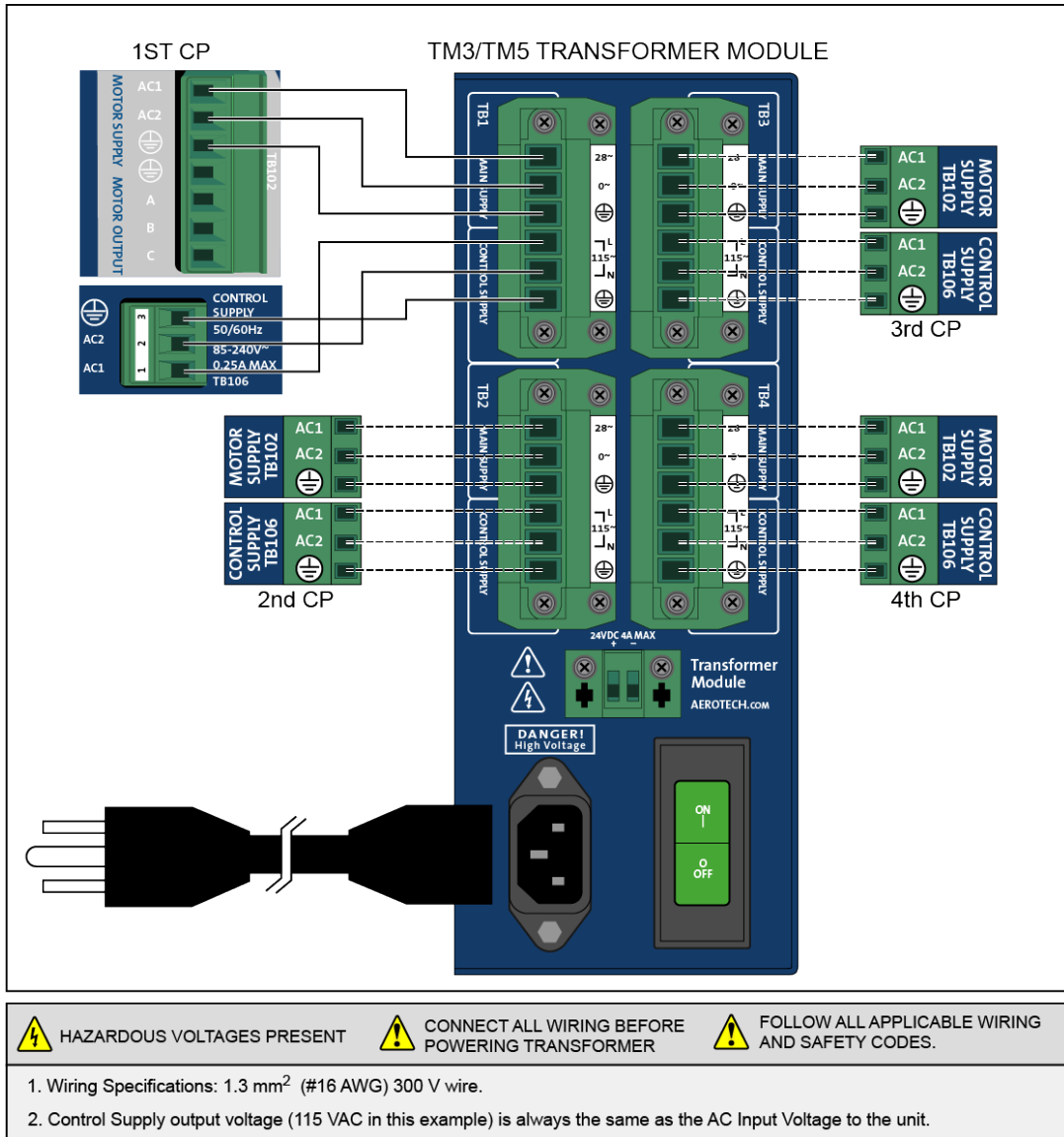

Figure 1-4: System Interconnect Example (CP)

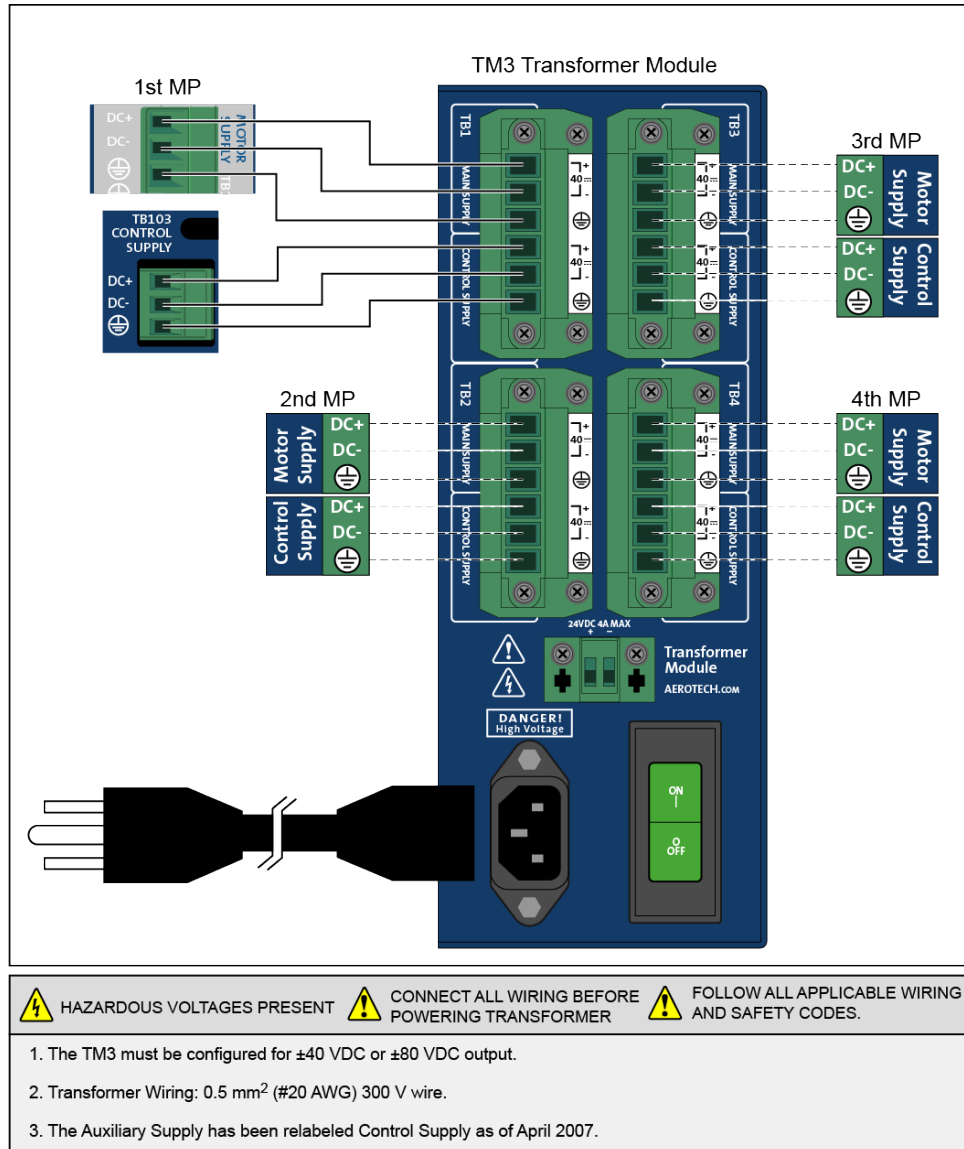

Figure 1-5: System Interconnect Example (MP)

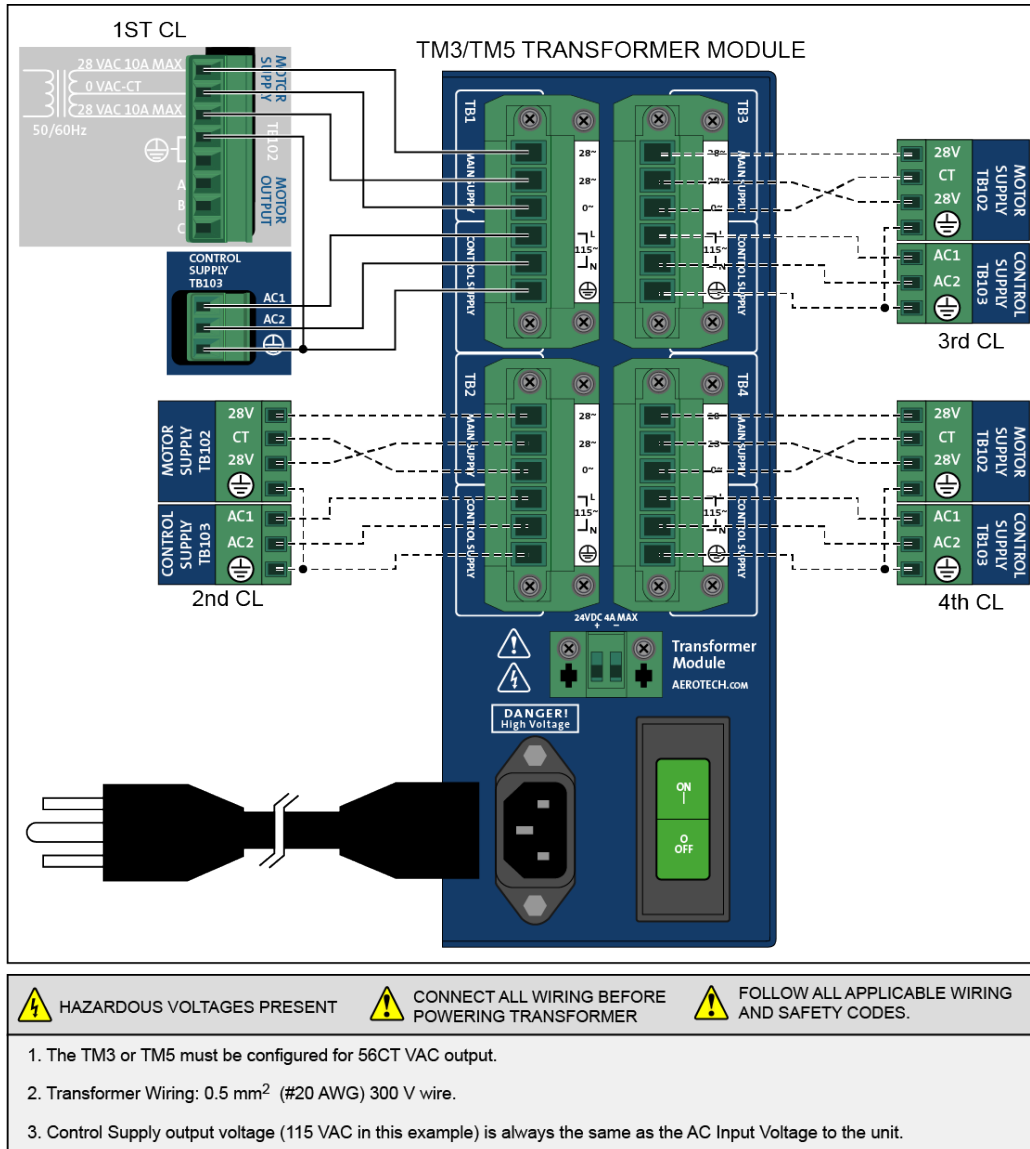

Figure 1-6: System Interconnect Example (CL)

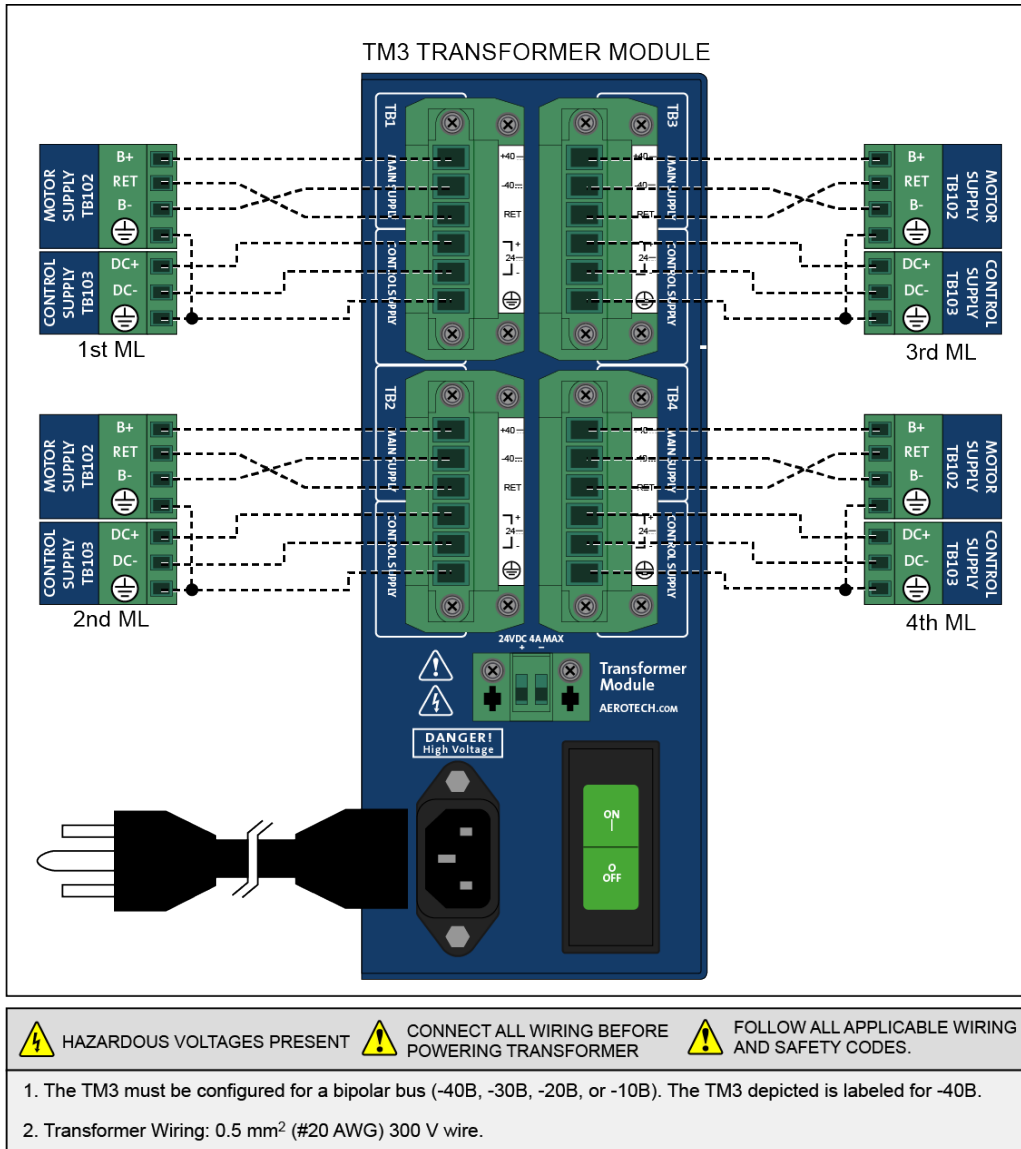

Figure 1-7: System Interconnect Example (ML)

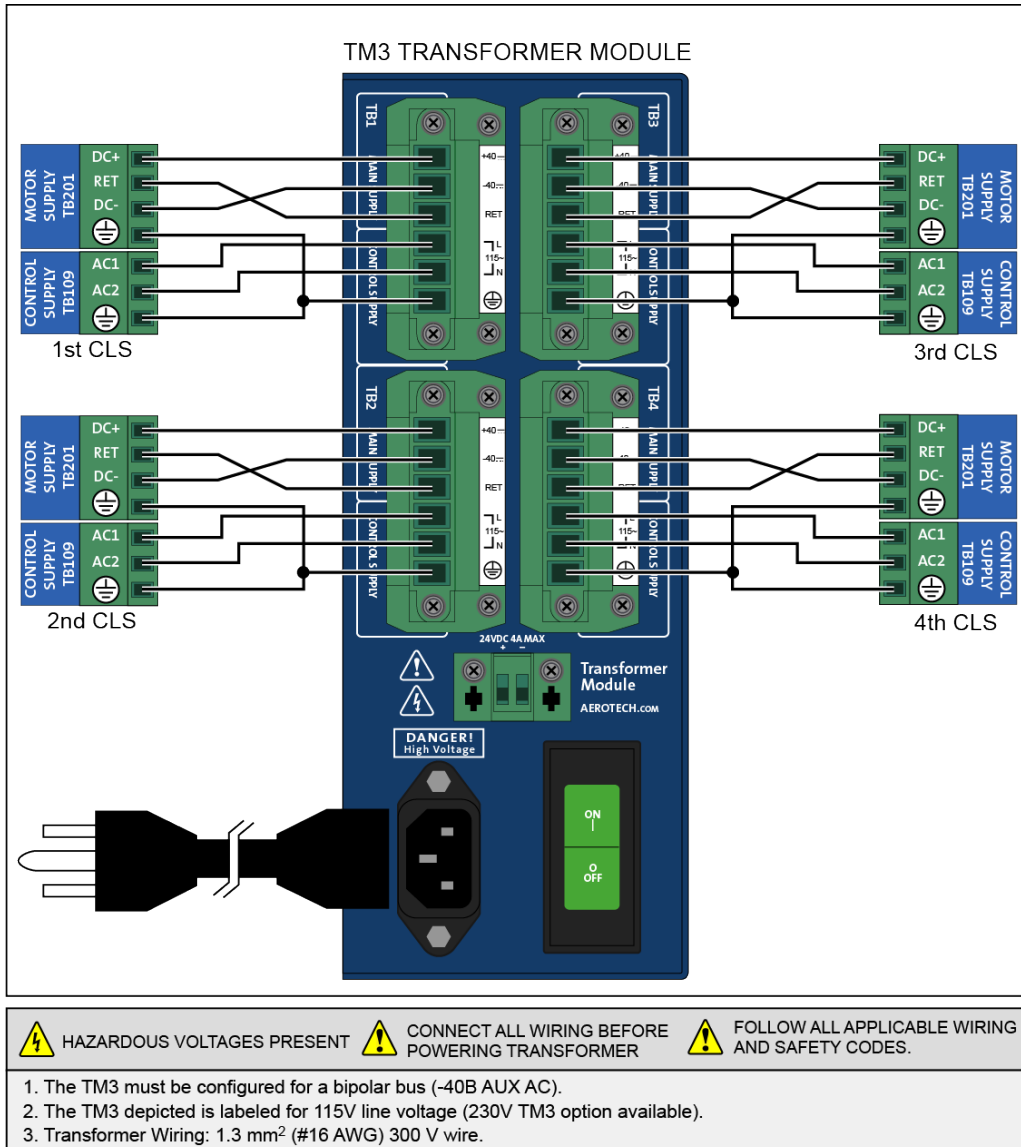

Figure 1-8: System Interconnect Example (Nmark CLS)

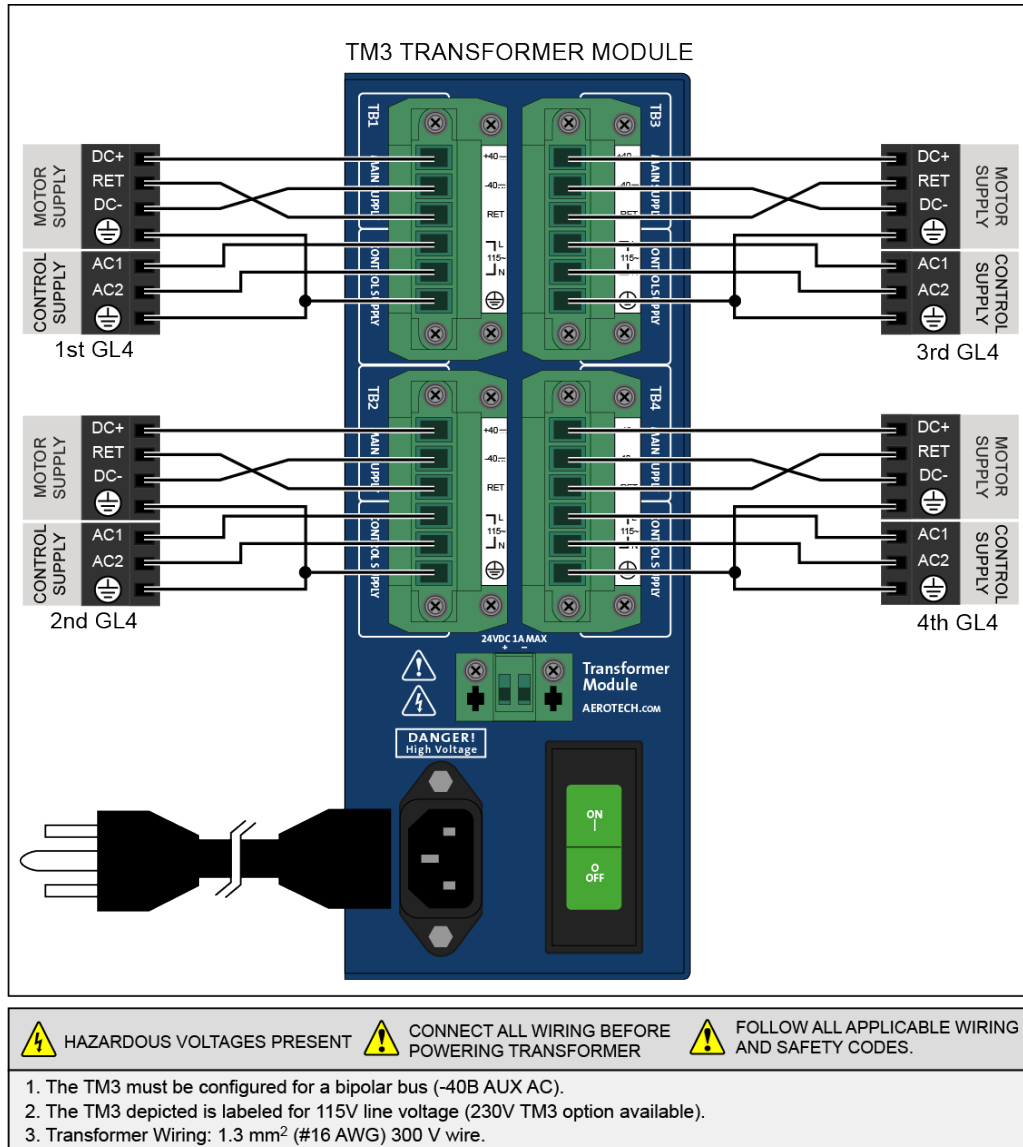

Figure 1-9: System Interconnect Example (GL4)

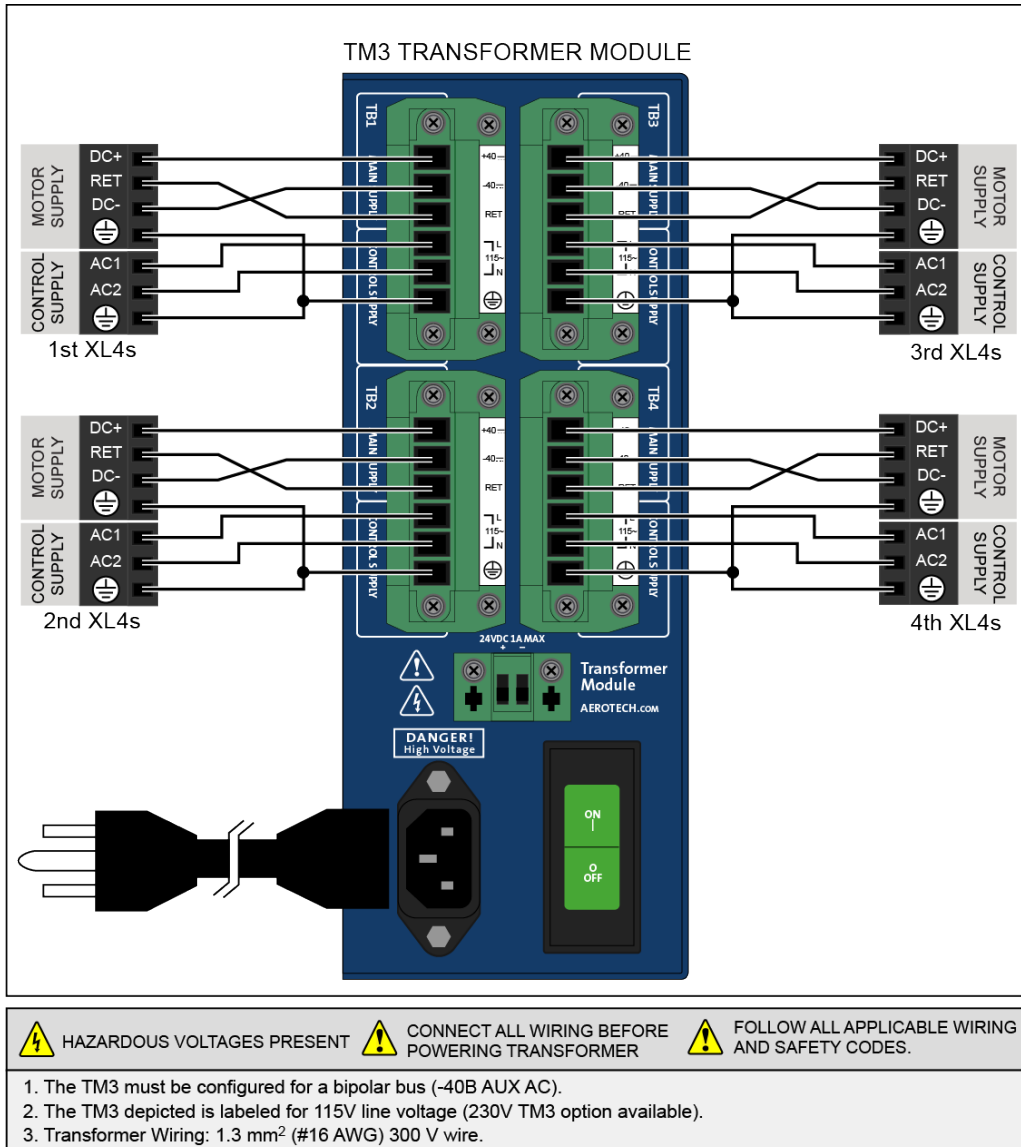

Figure 1-10: System Interconnect Example (XL4s)

1.2.6. AC Power Input

AC power is supplied to the TM3 via the AC inlet located next to the power switch / breaker. This connection is made through a standard line cord supplied with the TM3 transformer module. The AC power input ratings are listed on the power label on the TM3 transformer module.



WARNING: The AC Power inlet power connection is the Mains disconnect.



WARNING: To minimize the possibility of bodily injury or equipment damage make certain that the applied AC voltage matches the voltage listed on the TM3 rating tag.

1.2.7. Power Output Connections (TB1-TB4)

Each output connector provides a Main Supply output and Control Supply output. The Main Supply output is an AC or DC voltage that is designed to be connected to the main supply of an Aerotech controller. The Main Supply is normally referenced to ground. A fuse in the transformer primary circuit provides short circuit protection for the Main Supply output.

The Control Supply is an AC or DC voltage that is designed to be connected to the Control supply of an Aerotech controller. Offline Control Supply outputs (AC) are protected by the circuit breaker / power switch (10A breaker/switch is for 100/115 and 5A breaker is for 200/230 VAC input) located on the front of the TM3. A fuse in the transformer primary circuit provides short circuit protection for the Control Supply output when the Control Supply voltage is derived from the TM3 transformer.

Table 1-4: Power Output Connections (TB1-4)

Pin	Description	Recommended Wire Size	Connector
1	AC or DC output	1.3 mm ² (#16 AWG) rated @ 300V	
2	AC or DC output		
3	Protective Ground (required for safety)		
4	AC or DC output		
5	AC or DC output		
6	Protective Ground (required for safety)		

Table 1-5: Power Output Mating Connector

Type	Aerotech P/N	Phoenix P/N	Screw Torque Value: Nm	Wire Size: AWG [mm ²]
6-Pin Terminal Block	ECK01410	1828281	0.5 - 0.6	10-30 [5.27 - 0.0516]

1.2.8. +24 VDC Output [PS24-1]

The +24 VDC output has a maximum current output of 4 amps @ 20° C. The 24 VDC output is accessible at the 2-pin terminal block connector. The negative side of the 24 V supply is connected to chassis (ground).

Table 1-6: +24 VDC Output Connections

Pin	Label	Description	Recommended Wire Size	Connector
1	+	+24 VDC Output	0.3 mm ² (#22 AWG) rated @ 300 V	
2	-	- Side of supply (connected to chassis, ground)		

Table 1-7: +24 VDC Output Mating Connector

Type	Aerotech P/N	Phoenix P/N	Screw Torque Value: Nm	Wire Size: AWG [mm ²]
2-Pin Terminal Block	ECK01110	1754449	0.5 - 0.6	12-30 [3.3 - 0.0516]

NOTE: For a TM3 purchased before April 2016: The +24 VDC output has a maximum current output of 1 amps @ 20° C.

1.2.9. Soft-Start Voltage Selector Overview

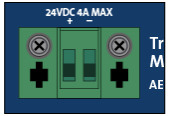
The Soft-Start / Voltage Selector Board is used to limit AC inrush current during turn-on. It also provides the user with the means to configure the TM3 for different AC line input voltages. The Soft-Start / Voltage Select Board is shown in. This board is accessible by removing the cover of the TM3.

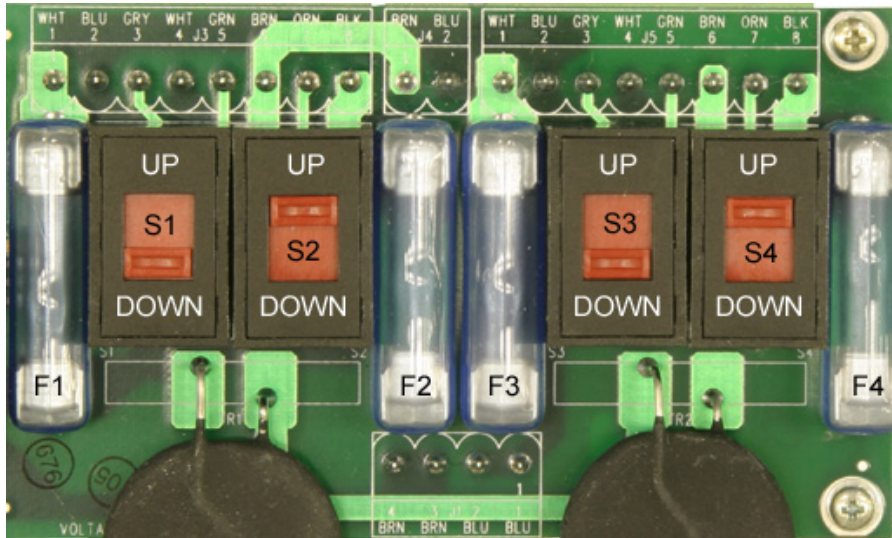

Figure 1-11: Soft-Start / Voltage Select Board



WARNING: S1 through S4 must be set for the applied AC power input voltage. Setting S1 through S4 incorrectly may result in damage to the system.



WARNING: Disconnect power to the TM3 before changing voltage selector switch settings (S1 through S4).

Table 1-8: Soft-Start/Voltage Selector Switch Settings

	Switch Settings			
	S1	S2	S3	S4
100 VAC	UP	DN	UP	DN
115 VAC	UP	UP	UP	UP
200 VAC	DN	DN	DN	DN
230 VAC	DN	UP	DN	UP

1.3. Operation

When power is applied to the TM3 transformer box and the power switch is in the ON position the Green power switch will be illuminated. The power switch can also be left on and the power to the TM3 transformer module can be turned ON and OFF remotely.



WARNING: The AC Power inlet power connection is the Mains disconnect.



WARNING: To minimize the possibility of bodily injury or equipment damage make certain that the applied AC voltage matches the voltage listed on the TM3 rating tag.



DANGER: To minimize the possibility of electrical shock and bodily injury or death, disconnect all electrical power prior to making any electrical connections.

1.4. Maintenance

This section covers troubleshooting, fuse replacement, preventative maintenance, and cleaning the TM3.



DANGER: Before performing any tests, be aware of lethal voltages inside the controller and at the input and output power connections. A qualified service technician or electrician should perform these tests.



WARNING: No user serviceable parts inside.



DANGER: Disconnect power to the TM3 main supply before servicing.



DANGER: Risk of electric shock.

1.4.1. Troubleshooting

Table 1-9 lists some common symptoms, causes and solutions for troubleshooting the TM3.

Table 1-9: Symptoms, Causes, and Solutions

Symptom	Possible Cause and Solution
No output power	<ul style="list-style-type: none"> • Verify Power Switch is ON & illuminated. • Verify AC Mains is connected to TM3 inlet. • Verify AC power to TM3. • If power switch is illuminated check F1 & F2 on Soft-Start / Voltage Select board inside TM3.
Power switch will not stay on	Overload or short on output, especially Control Supply outputs (Remove all output cables). Locate short and correct problem.
Output turns off after TM3 is on a while	<ul style="list-style-type: none"> • Transformer inside TM3 is getting too hot (requires cooling, exceeding power rating of transformer), verify that Main Supply outputs are not overloaded. • Verify that TM3 is configured for the AC line voltage supplied to it. Check Soft-Start / Voltage Select board switch settings
F1 or F2 on Soft-Start / Voltage Selector board opens	<ul style="list-style-type: none"> • Verify Fuse is correct value and type. • Check for short or overload on outputs. • Verify Voltage Selector switches on Soft-Start / Voltage Select board are set correctly.
There is no +24 Volt output	Verify that +24V supply is not overloaded or shorted (check by disconnecting +24V connector).

1.4.2. Fuse Replacement

The TM3 transformer Module contains two user replaceable fuses (F1 & F2) located on the Soft-Start / Voltage Select board. Both fuses are located in the primary circuit of the TM3 transformer and function to protect the transformer against shorts and severe overloads on the transformer output. Both fuses are Slow Blow type fuses in order to handle the high inrush currents when the TM3 is turned on. Table 1-10 lists fuse replacement information for the TM3.

Table 1-10: TM3 Fuse Replacement Part Numbers

Fuse	TM3 Configuration	Third Party P/N	Aerotech P/N	Size
F1	100VAC (-C) 115 VAC (-A)	Littelfuse PN: 313004	EIF00104	4 A. S. B. (3AG)
F2	200 VAC (-D) 230 VAC (-B)	Littelfuse PN: 313003	EIF00103	3 A. S. B. (3AG)

1.4.3. Preventative Maintenance

The TM3 and external wiring should be inspected monthly. Inspections may be required at more frequent intervals, depending on the environment and use of the system.



DANGER: Always disconnect the Mains power connection before opening the TM3 chassis.



DANGER: Risk of electric shock.



DANGER: To minimize the possibility of electrical shock and bodily injury or death, disconnect all electrical power prior to making any electrical connections.



WARNING: Disconnect electrical power to the motor before performing maintenance procedures. In addition, uncouple or otherwise prevent motor-coupled machinery from moving the motor during service.

NOTE: Do not use the TM3 (all Aerotech equipment) in a manner not specified by Aerotech, Inc.

Table 1-11: Preventative Maintenance

Check	Action to be Taken
Visually Check chassis for loose or damaged parts / hardware. Note: Internal inspection is not required.	Parts should be repaired as required. If internal damage is suspected, these parts should be checked and repairs made if necessary.
Inspect cooling vents.	Remove any accumulated material from vents.
Check for fluids or electrically conductive material exposure.	Any fluids or electrically conductive material must not be permitted to enter the TM3.
Visually inspect all cables and connections.	Tighten or re-secure any loose connections. Replace worn or frayed cables. Replace broken connectors.

Cleaning

The TM3 chassis can be wiped with a clean, dry, soft cloth. The cloth may be slightly moistened if required with water or isopropyl alcohol to aid in cleaning if necessary. In this case, be careful not to allow moisture to enter the TM3 or onto exposed connectors / components. Fluids and sprays are not recommended because of the chance for internal contamination, which may result in electrical shorts and/or corrosion. The electrical power must be disconnected from the TM3 while cleaning. Do not allow cleaning substances or other fluids to enter the TM3 or to get on to any of the connectors. Avoid cleaning labels to prevent removing the label information.

This page intentionally left blank.

Appendix A: Warranty and Field Service

Aerotech, Inc. warrants its products to be free from harmful defects caused by faulty materials or poor workmanship for a minimum period of one year from date of shipment from Aerotech. Aerotech's liability is limited to replacing, repairing or issuing credit, at its option, for any products that are returned by the original purchaser during the warranty period. Aerotech makes no warranty that its products are fit for the use or purpose to which they may be put by the buyer, whether or not such use or purpose has been disclosed to Aerotech in specifications or drawings previously or subsequently provided, or whether or not Aerotech's products are specifically designed and/or manufactured for buyer's use or purpose. Aerotech's liability on any claim for loss or damage arising out of the sale, resale, or use of any of its products shall in no event exceed the selling price of the unit.

THE EXPRESS WARRANTY SET FORTH HEREIN IS IN LIEU OF AND EXCLUDES ALL OTHER WARRANTIES, EXPRESSED OR IMPLIED, BY OPERATION OF LAW OR OTHERWISE. IN NO EVENT SHALL AEROTECH BE LIABLE FOR CONSEQUENTIAL OR SPECIAL DAMAGES.

Return Products Procedure

Claims for shipment damage (evident or concealed) must be filed with the carrier by the buyer. Aerotech must be notified within thirty (30) days of shipment of incorrect material. No product may be returned, whether in warranty or out of warranty, without first obtaining approval from Aerotech. No credit will be given nor repairs made for products returned without such approval. A "Return Materials Authorization (RMA)" number must accompany any returned product(s). The RMA number may be obtained by calling an Aerotech service center or by submitting the appropriate request available on our website (www.aerotech.com). Products must be returned, prepaid, to an Aerotech service center (no C.O.D. or Collect Freight accepted). The status of any product returned later than thirty (30) days after the issuance of a return authorization number will be subject to review.

Visit <https://www.aerotech.com/global-technical-support.aspx> for the location of your nearest Aerotech Service center.

Returned Product Warranty Determination

After Aerotech's examination, warranty or out-of-warranty status will be determined. If upon Aerotech's examination a warranted defect exists, then the product(s) will be repaired at no charge and shipped, prepaid, back to the buyer. If the buyer desires an expedited method of return, the product(s) will be shipped collect. Warranty repairs do not extend the original warranty period.

Fixed Fee Repairs - Products having fixed-fee pricing will require a valid purchase order or credit card particulars before any service work can begin.

All Other Repairs - After Aerotech's evaluation, the buyer shall be notified of the repair cost. At such time the buyer must issue a valid purchase order to cover the cost of the repair and freight, or authorize the product(s) to be shipped back as is, at the buyer's expense. Failure to obtain a purchase order number or approval within thirty (30) days of notification will result in the product(s) being returned as is, at the buyer's expense.

Repair work is warranted for ninety (90) days from date of shipment. Replacement components are warranted for one year from date of shipment.

Rush Service

At times, the buyer may desire to expedite a repair. Regardless of warranty or out-of-warranty status, the buyer must issue a valid purchase order to cover the added rush service cost. Rush service is subject to Aerotech's approval.

On-site Warranty Repair

If an Aerotech product cannot be made functional by telephone assistance or by sending and having the customer install replacement parts, and cannot be returned to the Aerotech service center for repair, and if Aerotech determines the problem could be warranty-related, then the following policy applies:

Aerotech will provide an on-site Field Service Representative in a reasonable amount of time, provided that the customer issues a valid purchase order to Aerotech covering all transportation and subsistence costs. For warranty field repairs, the customer will not be charged for the cost of labor and material. If service is rendered at times other than normal work periods, then special rates apply.

If during the on-site repair it is determined the problem is not warranty related, then the terms and conditions stated in the following "On-Site Non-Warranty Repair" section apply.

On-site Non-Warranty Repair

If any Aerotech product cannot be made functional by telephone assistance or purchased replacement parts, and cannot be returned to the Aerotech service center for repair, then the following field service policy applies:

Aerotech will provide an on-site Field Service Representative in a reasonable amount of time, provided that the customer issues a valid purchase order to Aerotech covering all transportation and subsistence costs and the prevailing labor cost, including travel time, necessary to complete the repair.

Service Locations

<http://www.aerotech.com/contact-sales.aspx?mapState=showMap>

USA, CANADA, MEXICO	CHINA	GERMANY
Aerotech, Inc. Global Headquarters Phone: +1-412-967-6440 Fax: +1-412-967-6870	Aerotech China Full-Service Subsidiary Phone: +86 (21) 5508 6731	Aerotech Germany Full-Service Subsidiary Phone: +49 (0)911 967 9370 Fax: +49 (0)911 967 93720
JAPAN	TAIWAN	UNITED KINGDOM
Aerotech Japan Full-Service Subsidiary Phone: +81 (0)50 5830 6814 Fax: +81 (0)43 306 3773	Aerotech Taiwan Full-Service Subsidiary Phone: +886 (0)2 8751 6690	Aerotech United Kingdom Full-Service Subsidiary Phone: +44 (0)1256 855055 Fax: +44 (0)1256 855649

Have your customer order number ready before calling.

Appendix B: Revision History

Revision	Description
2.02.00	<ul style="list-style-type: none"> • EU Declaration of Conformity • Agency Approvals • Added GL4 and XL4s to Section 1.2.5. • Section 1.2.8. +24 VDC Output [PS24-1]
2.01.00	<ul style="list-style-type: none"> • Updated Danger/Warning notes • Added TUV certification information: Agency Approvals • Added RoHS statement: EU Declaration of Conformity • Added wiring screw torque specification: Section 1.2.7., Section 1.2.8. • Updated voltage specifications: Chapter 1: TM3 Transformer Module, Section 1.1., Table 1-1, Section 1.2.9., Section 1.4.2.
2.00.00	Revision changes have been archived. If you need a copy of this revision, contact Aerotech Global Technical Support.
1.01.00	
1.00.00	

This page intentionally left blank.

Index

			L	
	2		Line Cord Options	12
2014/35/EU		7		
	A		M	
AC Power Input		12	Mechanical Specifications	14
Axis Split		12	ML	21
	B		MP	19
Bus Voltage 1 & 2		12		
	C		N	
Cable Type		12	Nmark CLS	22
Check chassis for loose or damaged parts / hardware		31		
Check for fluids or electrically conductive material exposure		31	O	
CL		20	Optional Brake Cable	12
Cleaning		31		
Control & Main Supply Cables		12	P	
CP		18	Power Supply	12
	E			
EN 61010-1		7	S	
	G		Standard Cable Lengths	12
GL4		23	Support	2
Global Technical Support		2	System Interconnection	17
	H			
Handling and Transportation		14	T	
HPe		17	Technical Support	2
	I			
inspect all cables and connections		31	X	
Inspect cooling vents		31	XL4s	24
Inspection		31		
Installation		14		
Installation and Mounting		14		

This page intentionally left blank.