

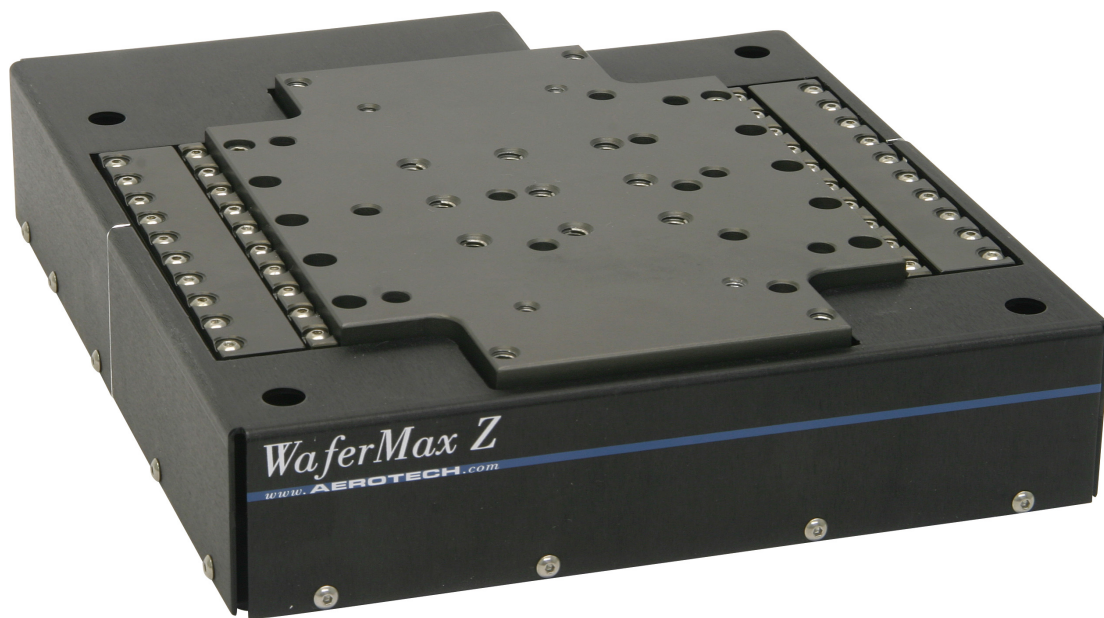

WaferMaxZ Hardware Manual

Revision: 1.01.00



Global Technical Support

Go to www.aerotech.com/global-technical-support for information and support about your Aerotech products. The website provides downloadable resources (such as up-to-date software, product manuals, and Help files), training schedules, and PC-to-PC remote technical support. You can also complete Product Return (RMA) forms and get information about repairs and spare or replacement parts. For immediate help, contact a service office or your sales representative. Have your customer order number available before you call or include it in your email.

United States (World Headquarters)	
Phone: +1-412-967-6440 Fax: +1-412-967-6870 Email: service@aerotech.com	101 Zeta Drive Pittsburgh, PA 15238-2811 www.aerotech.com
United Kingdom	Japan
Phone: +44 (0)1256 855055 Fax: +44 (0)1256 855649 Email: service@aerotech.co.uk	Phone: +81 (0)50 5830 6814 Fax: +81 (0)43 306 3773 Email: service@aerotechkk.co.jp
Germany	China
Phone: +49 (0)911 967 9370 Fax: +49 (0)911 967 93720 Email: service@aerotechgmbh.de	Phone: +86 (21) 3319 7715 Email: service@aerotech.com
France	Taiwan
Phone: +33 2 37 21 87 65 Email: service@aerotech.co.uk	Phone: +886 (0)2 8751 6690 Email: service@aerotech.tw

This manual contains proprietary information and may not be reproduced, disclosed, or used in whole or in part without the express written permission of Aerotech, Inc. Product names mentioned herein are used for identification purposes only and may be trademarks of their respective companies.

Copyright © 2013-2017, Aerotech, Inc., All rights reserved.

Aerotech Worldwide

United States ■ France ■ Germany ■ United Kingdom
China ■ Japan ■ Taiwan



Table of Contents

WaferMaxZ Hardware Manual **1**

 Table of Contents 3

 List of Figures 4

 List of Tables 5

 EU Declaration of Incorporation 6

 Safety Procedures and Warnings 7

Chapter 1: Overview **9**

 1.1. Environmental Specifications 10

 1.2. Accuracy and Temperature Effects 10

 1.3. Basic Specifications 11

 1.4. Vacuum Operation 12

Chapter 2: Installation **13**

 2.1. Unpacking and Handling the Stage 13

 2.2. Dimensions 14

 2.3. Securing the Stage to the Mounting Surface 15

 2.4. Attaching the Payload to the Stage 17

 2.5. Air Requirements 19

 2.6. Counterbalance Setup 20

Chapter 3: Electrical Installation **23**

 3.1. Motor and Feedback Connectors 24

 3.2. Motor and Feedback Wiring 27

 3.3. Motor and Feedback Specifications 28

 3.4. Limits, Marker, and Machine Direction 30

 3.5. Motor and Feedback Phasing 31

Chapter 4: Maintenance **33**

 4.1. Service and Inspection Schedule 33

 4.2. Cleaning and Lubrication 34

 4.3. Flexure Constraints 36

 4.4. Troubleshooting 37

Appendix A: Warranty and Field Service **39**

Appendix B: Revision History **41**

Index **43**

List of Figures

Figure 2-1: WaferMaxZ Dimensions 14
Figure 2-2: Mounting Hole Locations 16
Figure 2-3: Payload Mounting Hole Locations 18
Figure 2-4: Counterbalance Pressure vs. External Payload 20
Figure 2-5: Counterbalance Air Flow vs Counterbalance Pressure 21
Figure 3-1: Motor and Feedback Wiring 27
Figure 3-2: Machine Direction 30
Figure 3-3: Hall Phasing 31
Figure 3-4: Analog Encoder Phasing Reference Diagram 32
Figure 4-1: Cutaway View of an WaferMaxZ Flexure 36

List of Tables

Table 1-1: Model Numbering System 9
Table 1-2: Environmental Specifications 10
Table 1-3: WaferMaxZ Series Specifications 11
Table 2-1: Stage to Mounting Surface Hardware 16
Table 2-2: Table: Customer Mounting Features 18
Table 3-1: Motor Pin Assignments 25
Table 3-2: Feedback Pin Assignments 26
Table 3-3: Feedback Specifications 28
Table 3-4: WaferMaxZ Motor Specifications (BLMUC-95 Motor) 29

EU Declaration of Incorporation

Manufacturer: Aerotech, Inc.
101 Zeta Drive
Pittsburgh, PA 15238-2811
USA

herewith declares that the product:
WaferMaxZ Stage

is intended to be incorporated into machinery to constitute machinery covered by the Directive 2006/42/EC as amended;

and that the following harmonized European standards have been applied:

EN ISO 12100:2010

Safety of machinery - Basic concepts, general principles for design

EN 60204-1:2010

Safety of machinery - Electrical equipment of machines - Part 1: General requirements

and further more declares that

it is not allowed to put the equipment into service until the machinery into which it is to be incorporated or of which it is to be a component has been found and declared to be in conformity with the provisions of the Directive 2006/42/EC and with national implementing legislation, i.e., as a whole, including the equipment referred to in this Declaration.

This is to certify that the aforementioned product is in accordance with the applicable requirements of the following Directive(s):

2011/65/EU

RoHS 2 Directive

Authorized Representative: Simon Smith, European Director
Address: Aerotech Ltd
The Old Brick Kiln
Ramsdell, Tadley
Hampshire RG26 5PR
UK

Name  / Alex Weibel
Position Engineer Verifying Compliance
Location Pittsburgh, PA

Safety Procedures and Warnings

Read this manual in its entirety before installing, operating, or servicing this product. If you do not understand the information contained herein, contact an Aerotech representative before proceeding. Strictly adhere to the statements given in this section and other handling, use, and operational information given throughout the manual to avoid injury to you and damage to the equipment.

The following statements apply wherever the Warning or Danger symbol appears within this manual. Failure to observe these precautions could result in serious injury to those individuals performing the procedures and/or damage to the equipment.



DANGER: This product contains potentially lethal voltages. To reduce the possibility of electrical shock, bodily injury, or death the following precautions must be followed.

1. Access to the WaferMaxZ and component parts must be restricted while connected to a power source.
2. Do not connect or disconnect any electrical components or connecting cables while connected to a power source.
3. Disconnect electrical power before servicing equipment.
4. All components must be properly grounded in accordance with local electrical safety requirements.
5. Operator safeguarding requirements must be addressed during final integration of the product.



WARNING: To minimize the possibility of electrical shock, bodily injury or death the following precautions must be followed.

1. Moving parts can cause crushing or shearing injuries. Access to all stage and motor parts must be restricted while connected to a power source.
2. Cables can pose a tripping hazard. Securely mount and position all system cables to avoid potential hazards.
3. Do not expose this product to environments or conditions outside of the listed specifications. Exceeding environmental or operating specifications can cause damage to the equipment.
4. The WaferMaxZ stage must be mounted securely. Improper mounting can result in injury and damage to the equipment.
5. Use care when moving the WaferMaxZ stage. Lifting or transporting the WaferMaxZ stage improperly can result in injury or damage to the WaferMaxZ.
6. This product is intended for light industrial manufacturing or laboratory use. Use of this product for unintended applications can result in injury and damage to the equipment.
7. If the product is used in a manner not specified by the manufacturer, the protection provided by the product can be impaired and result in damage, shock, injury, or death.
8. Operators must be trained before operating this equipment.
9. All service and maintenance must be performed by qualified personnel.
10. Eye protection must be worn when in the proximity of compressed air components.

This page intentionally left blank.

Chapter 1: Overview

NOTE: Aerotech continually improves its product offerings; listed options may be superseded at any time. All drawings and illustrations are for reference only and were complete and accurate as of this manual's release. Refer to www.aerotech.com for the most up-to-date information.

Table 1-1: Model Numbering System

Model	
WaferMaxZ	Mechanical-bearing direct-drive lift stage

1.1. Environmental Specifications



WARNING: Do not expose this product to environments or conditions outside of the listed specifications. Exceeding environmental or operating specifications can cause damage to the equipment.

Table 1-2: Environmental Specifications

Ambient Temperature	Operating: 10° to 35°C (50° to 95°F) The optimal operating temperature is 20°C ±2°C (68°F ±4°F). If at any time the operating temperature deviates from 20°C degradation in performance could occur.
	Storage: 0° to 40°C (32° to 104°F) in original shipping packaging
Humidity	Operating: 20% to 60% RH
	Storage: 10% to 70% RH, non-condensing in original packaging. The stage should be packaged with desiccant if it is to be stored for an extended time.
Altitude	Operating: 0 m to 2,000 m (0 ft to 6,562 ft) above sea level Contact Aerotech if your specific application involves use above 2,000 m or below sea level.
Vibration	Use the system in a low vibration environment. Excessive floor or acoustical vibration can affect system performance. Contact Aerotech for information regarding your specific application.
Protection Rating	The WaferMaxZ is not suitable for dusty or wet environments. This equates to an ingress protection rating of IP00.
Use	Indoor use only

1.2. Accuracy and Temperature Effects

Aerotech products are designed for and built in a 20°C (68°F) environment. Extreme temperature changes could cause a decrease in performance or permanent damage to the WaferMaxZ. At a minimum, the environmental temperature must be controlled to within 0.25°C per 24 hours to ensure the WaferMaxZ specifications are repeatable over an extended period of time. The severity of temperature effects on all specifications depends on many different environmental conditions, including how the WaferMaxZ is mounted. Contact the factory for more details.

The thermal expansion coefficient of the encoder scale is 10 ppm/°C. The encoder measures the linear wedge, not the tabletop. The wedge ratio of the WaferMaxZ is 12:1, so the effective thermal expansion of the encoder scale as seen at the tabletop is $10/12 = 0.833$ ppm/°C. Travel will increase or decrease at this rate as the encoder scale temperature deviates from 20°C (68°F).

1.3. Basic Specifications

NOTE: Aerotech continually improves its product offerings; listed options may be superseded at any time. All drawings and illustrations are for reference only and were complete and accurate as of this manual's release. Refer to www.aerotech.com for the most up-to-date information.

Table 1-3: WaferMaxZ Series Specifications

		WaferMaxZ
Travel		5 mm
Motor Type		Direct-Drive Brushless Linear Motor
Bus Voltage		up to 160 VDC
Continuous Current	A _{pk}	2.9 A
	A _{rms}	2.1 A
Encoder		20 μm fundamental; amplified sine output
Resolution (Minimum incremental motion.)		0.83 nm
Accuracy ^(1,3)		±1.5 μm
Bidirectional Repeatability ⁽³⁾		±0.3 μm
Straightness ⁽⁴⁾		±2 μm
Roll		20 arc sec
Pitch		20 arc sec
Yaw		20 arc sec
Maximum Speed		4 mm/s
Maximum Load ⁽⁵⁾		10 kg (requires use of integral pneumatic counterbalance)
Moving Mass		1.0 kg
Wedge Ratio		12:1
Stage Mass		4.2 kg
Material		Aluminum
Finish		Black anodize hard cover; Hard coat (62 Rockwell Hardness) tabletop
1. Requires the use of an Aerotech controller. 2. For inverted operation, consult factory. 3. Certified with each stage 4. Measured perpendicular or parallel to wedge direction. 5. Higher maximum loads possible. Contact the factory for details. 6. Specifications are per axis measured 25 mm above the tabletop without a payload. Performance is payload and work-point dependent. Consult factory for multi-axis or non-standard applications.		

1.4. Vacuum Operation

Due to the pneumatic counterbalance design of this stage, it cannot be operated in a vacuum environment.

Chapter 2: Installation



WARNING: WaferMaxZ installation must be in accordance to instructions provided by this manual and any accompanying documentation. Failure to follow these instructions could result in injury or damage to the equipment.

2.1. Unpacking and Handling the Stage



WARNING: It is the customer's responsibility to safely and carefully lift and move the WaferMaxZ.

- Secure all moving parts before lifting or moving the WaferMaxZ to a new location. Unsecured moving parts could shift and cause bodily injury.
- Improper handling could adversely affect the WaferMaxZ's performance. Use care when lifting or moving the WaferMaxZ.

Carefully remove the WaferMaxZ from its protective shipping container. Gently set the WaferMaxZ on a smooth, flat, and clean surface.

Before operating the WaferMaxZ, it is important to let it stabilize at room temperature for at least 12 hours. Allowing it to stabilize to room temperature will ensure that all of the alignments, preloads, and tolerances are the same as they were when tested at Aerotech. Use compressed nitrogen or clean, dry, oil-less air to remove any dust or debris that has collected during shipping.

Each WaferMaxZ has a label listing the system part number and serial number. These numbers contain information necessary for maintaining or updating system hardware and software. Locate this label and record the information for later reference.

2.2. Dimensions

NOTE: Aerotech continually improves its product offerings; listed options may be superseded at any time. All drawings and illustrations are for reference only and were complete and accurate as of this manual's release. Refer to www.aerotech.com for the most up-to-date information.

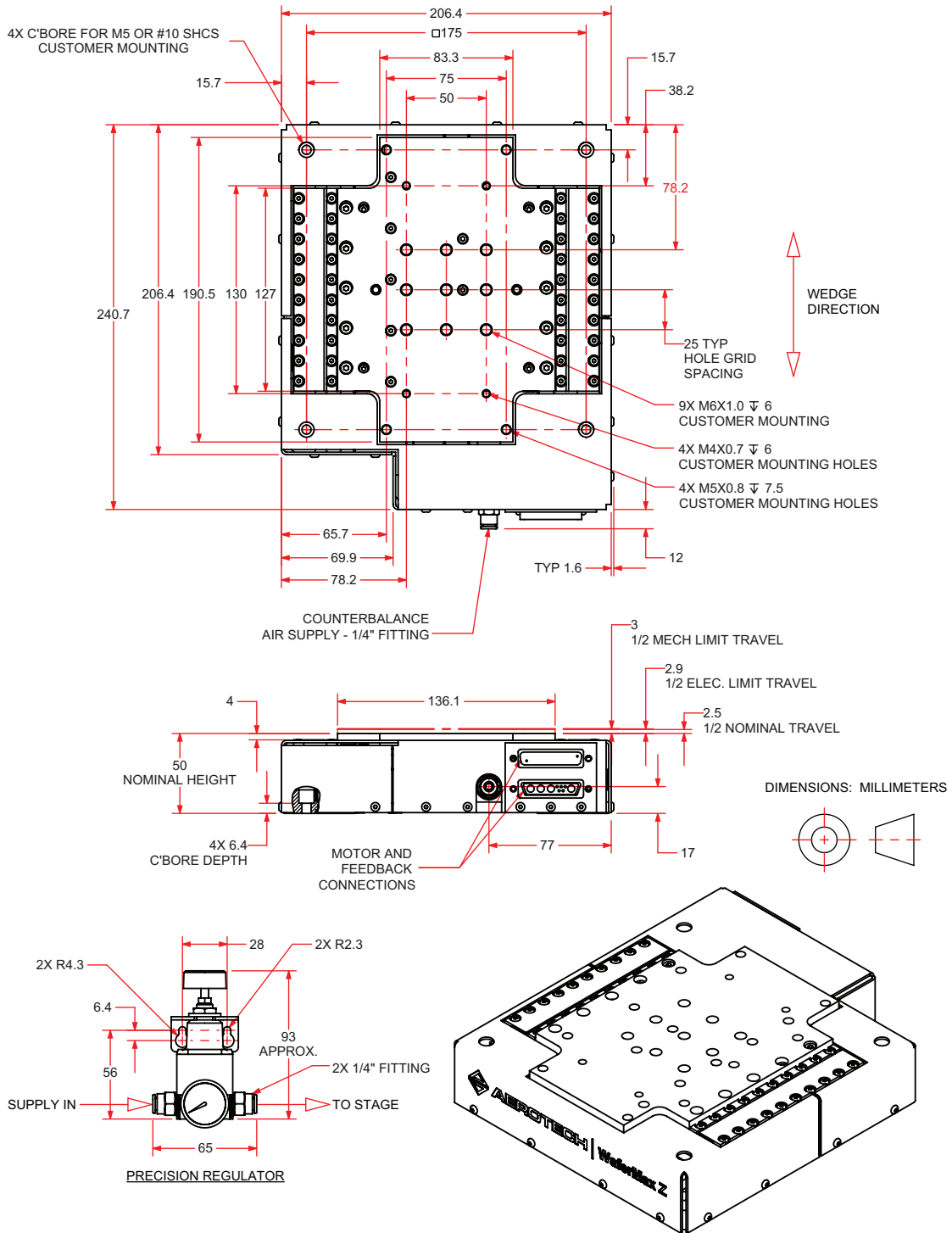

Figure 2-1: WaferMaxZ Dimensions

2.3. Securing the Stage to the Mounting Surface



WARNING: The WaferMaxZ must be mounted securely. Improper mounting can result in injury and damage to the equipment.



WARNING: Make sure that all moving parts are secure before moving the WaferMaxZ. Unsecured moving parts may shift and cause bodily injury.



DANGER: PINCH POINT! Keep Hands Clear while the stage is in motion.

The mounting surface must be flat and have adequate stiffness in order to achieve the maximum performance from the WaferMaxZ stage. When it is mounted to a non-flat surface, the stage can be distorted as the mounting screws are tightened. This distortion will decrease overall accuracy. Adjustments to the mounting surface must be done before the stage is secured.

Inspect the mounting surface for dirt or unwanted residue and clean if necessary. Use precision flatstones on the mounting surface to remove any burrs or high spots. Clean the mounting surface with a lint free cloth and acetone or isopropyl alcohol and allow the cleaning solvent to completely dry. Gently place the stage on the mounting surface.

NOTE: To maintain accuracy, the mounting surface must be flat to within 7.5 μm .

NOTE: The WaferMaxZ is precision machined and verified for flatness prior to product assembly at the factory. If machining is required to achieve the desired flatness, it should be performed on the mounting surface rather than the WaferMaxZ. Shimming should be avoided if possible. If shimming is required, it should be minimized to retain maximum rigidity of the system.

This stage is designed to use socket head cap screws (SHCS) to secure the base to the mounting surface (refer to [Figure 2-2](#)). There is a gap between the clearance holes in the cover and the counter-bores in the base for the mounting screws. It may be necessary to remove the cover of the WaferMaxZ to properly install or remove the mounting hardware. To remove the cover, remove all of the 24 M3 button head screws around the perimeter of the stage using a 2 mm hex wrench. The split-cover design is intended to make it easy to remove and replace the cover even if the payload of the stage is attached.

If it is necessary to remove the cover to mount the stage, make sure that the stage is not connected to its power source. Be careful not to damage any of the sensitive internal components of the stage while the cover is removed. Replace the cover as soon as the mounting screws are secured to protect the stage during additional setup and operation.

Tightening torque values for the mounting hardware are dependent on the properties of the surface to which the stage is being mounted. Values provided in [Table 2-1](#) are typical values and may not be accurate for your mounting surface. Refer to [Section 2.2](#) for specific model mounting locations and dimensions.

Table 2-1: Stage to Mounting Surface Hardware

Mounting Hardware	Typical Screw Torque
M5 by 16 mm [#10-32 x 5/8 in] SHCS	4 N·m

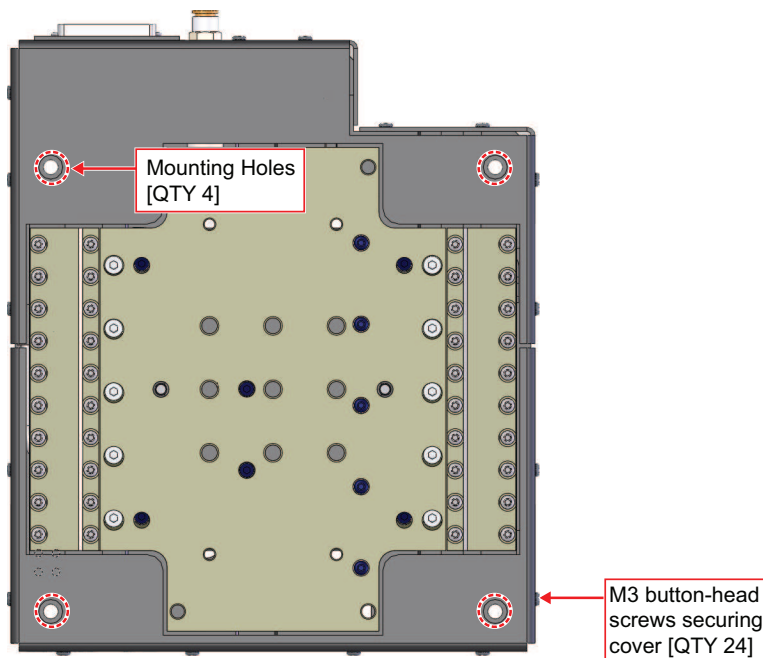

Figure 2-2: Mounting Hole Locations

2.4. Attaching the Payload to the Stage

Inspect the mounting surface for dirt or unwanted residue and clean if necessary. Clean the mounting surface with a lint free cloth and acetone or isopropyl alcohol and allow the cleaning solvent to completely dry.

To prevent damage to the payload or stage, test the operation of the stage before the payload is attached. Aerotech recommends that customers use a representative payload during start-up to prevent accidental damage to the stage and the payload. Proceed with the electrical installation (including setting up the pneumatic counterbalance) and test the motion control system in accordance with the system documentation. Refer to [Section 2.6](#) for counterbalance setup procedure. Document all results for future reference. For information on electrical installation refer to [Chapter 3](#) and the documentation delivered with the stage.

NOTE: If your WaferMaxZ was purchased with Aerotech controls, it might have been tuned with a representative payload based on the information provided at the time of order. If the WaferMaxZ is started up without a payload, the servo gains provided by Aerotech with the shipment may not be appropriate and servo instability can occur. Refer to the controller help file for tuning assistance.

The payload must be flat, rigid, and comparable to the stage in quality to maintain optimum performance.

NOTE: For valid system performance, the mounting interface should be flat within 10 μm .



WARNING: Refer to the dimensions in [Section 2.2](#) for maximum allowable thread engagement. A screw extending through the stage table can affect travel and damage the stage.

Applied loads should be symmetrically distributed whenever possible (i.e., the payload should be centered on the stage table and the entire stage should be centered on the support structure).

Table 2-2: Table: Customer Mounting Features

Mounting Hardware	Quantity
M6X1.0, 6 mm deep	9 places
M4X0.7, 6 mm deep	4 places

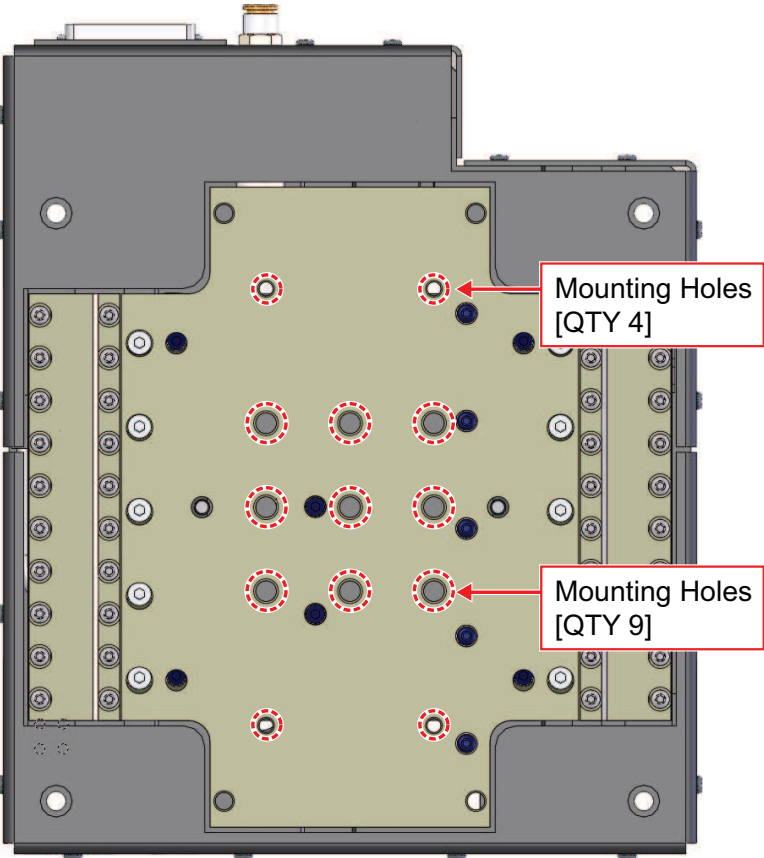

Figure 2-3: Payload Mounting Hole Locations

2.5. Air Requirements



WARNING: Eye protection must be worn when in the proximity of compressed air components.

The WaferMaxZ has a pneumatic counterbalance that counteracts the weight of the payload. It is important to the operation of the WaferMaxZ that the air supply to the counterbalance meets Aerotech specifications. The air must be filtered to 0.25 microns, dry to 0°F dew point, and oil free (nitrogen at 99.99% purity is recommended). Filtration is required to prevent particles from clogging internal components of the WaferMaxZ. If you need assistance with air filtration, contact Aerotech.

The pneumatic counterbalance supply pressure and flow rate is determined by the amount of payload carried by the stage (refer to [Figure 2-4](#) and [Figure 2-5](#)).

2.6. Counterbalance Setup



WARNING: Failure to adjust the counterbalance per the following instructions could result in bodily injury as well as stage and payload damage.



WARNING: Eye protection must be worn when in the proximity of compressed air components.

By default, the WaferMaxZ pneumatic counterbalance is factory set to operate in the as-shipped condition. For stages that are shipped unloaded, the counterbalance is set for the mass of the carriage only. For stages that ship with payloads or other axes attached, the counterbalance is set for the mass of the carriage plus the additional mass. Any adjustment to the mass that is carried by the counterbalance cylinder, either adding or subtracting payload, necessitates an adjustment to the counterbalance pressure supplied to the pneumatic cylinder.

Standard WaferMaxZ stages have one counterbalance cylinder with a piston area of $6.77 \times 10^{-5} \text{ m}^2$. The required counterbalance pressure for a given payload can be estimated using the following formula where Payload Weight is specified in Newtons:

$$\text{Pressure (MPa)} = [(\text{Payload Weight}) / 812.4 \text{ N/MPa}] + 0.008 \text{ MPa}$$

This relationship is shown graphically in [Figure 2-4](#).

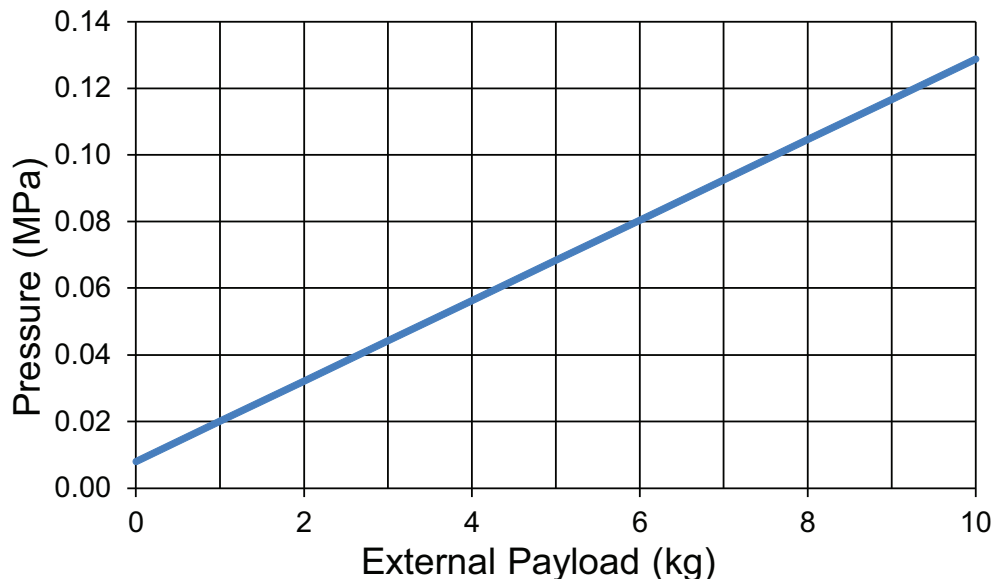

Figure 2-4: Counterbalance Pressure vs. External Payload

The flow required from the air supply is based on counterbalance pressure and can be estimated with [Figure 2-5](#).

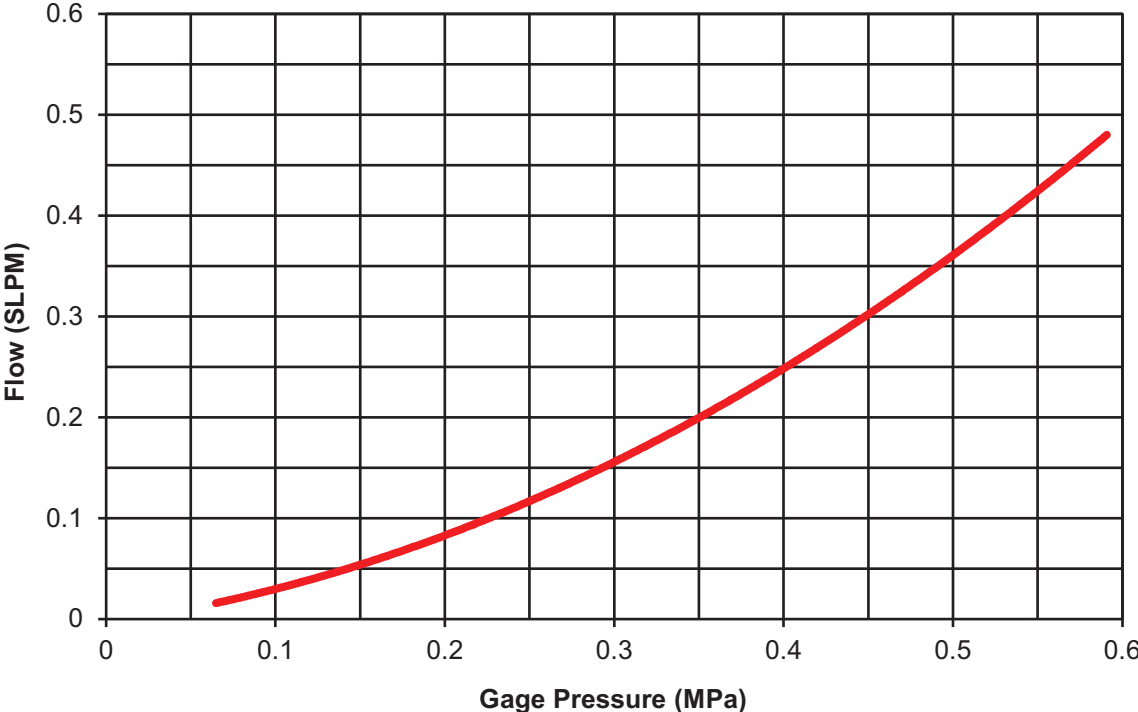

Figure 2-5: Counterbalance Air Flow vs Counterbalance Pressure

Procedure for initial pneumatic counterbalance setup:

1. Connect the air supply and counterbalance regulator to the WaferMaxZ. Refer to [Section 2.2](#) for regulator details.
 - a. Remove the shipping plug from the counterbalance fitting on the back of the stage.
 - b. Attach the regulator outlet to the stage with a 0.25 inch OD, polyurethane air tube.
 - c. With the air supply turned off, connect the supply to the regulator inlet. The inlet accepts a 0.25 inch OD, polyurethane air tube.
2. Turn the regulator knob counterclockwise to close off the air supply to the stage.

NOTE: Refer to [Section 0.1](#) for air requirements. Be sure that the air supply meets specifications prior to continuing.

3. Turn on the air supply to the regulator.
4. Estimate pressure required using the formula provided or by referencing [Figure 2-4](#).
5. Slowly increase regulator pressure by turning the regulator knob clockwise until the carriage begins to move. Adjust the pressure so that the carriage does not rise or drop when it is at the approximate center of travel.

To turn off the air supply to the stage:

1. Make sure the stage is not under servo control.
2. Gently push the carriage down to the bottom of travel until the mechanical stop engages.
3. Turn off the counterbalance pressure. Once the counterbalance pressure has completely bled out, release the hand pressure on the carriage.

To change the payload on the stage (add or remove mass):

1. Follow the steps above for turning off the air to the stage
2. Turn the regulator knob on the back of the angle bracket counterclockwise until it bottoms out (prevents any pressure from reaching the cylinders).
3. Change the payload as required. Refer to [Section 2.4](#) for payload flatness requirements.
4. Estimate the pressure required to lift the payload using the formula provided or by referencing [Figure 2-4](#).
5. Turn on the air supply to the counterbalance input
6. Gradually increase the pressure to the cylinder with the precision regulator. Make fine adjustments when approaching the estimated pressure required for counterbalance. Adjust until the payload does not rise or drop when it is at the approximate center of travel.

Chapter 3: Electrical Installation



WARNING: Electrical installation must be performed by properly qualified personnel.

Electrical installation requirements will vary depending on product options. Installation instructions in this section are for WaferMaxZs equipped with standard Aerotech motors intended for use with an Aerotech motion control system. Contact Aerotech for further information regarding products that are otherwise configured.

Aerotech motion control systems are adjusted at the factory for optimum performance. When the WaferMaxZ is part of a complete Aerotech motion control system, setup usually involves connecting the WaferMaxZ to the appropriate drive chassis with the cables provided. Labels on the system components usually indicate the appropriate connections.

If system level integration was purchased, an electrical drawing showing system interconnects has been supplied with the system (separate from this documentation).

The electrical wiring from the motor and encoder are integrated at the factory. Refer to the following sections for standard motor wiring and connector pin assignments.



WARNING: Applications requiring access to the stage while it is energized will require additional grounding and safeguards. The System Integrator or qualified installer is responsible for determining and meeting all safety and compliance requirements necessary for the integration of this stage into the final application.



DANGER: Remove power before connecting or disconnecting electrical components or cables. Failure to do so may cause electric shock.



WARNING: Operator access to the base and tabletop must be restricted while connected to a power source. Failure to do so may cause electric shock.

3.1. Motor and Feedback Connectors

Stages equipped with standard motors and encoders come from the factory completely wired and assembled.

NOTE: Refer to the other documentation accompanying your Aerotech equipment. Call your Aerotech representative if there are any questions on system configuration.

NOTE: If using standard Aerotech motors and cables, motor and encoder connection adjustments are not required.

The WaferMaxZ's protective ground connection provides motor frame ground protection only. Additional grounding and safety safeguards are required for applications requiring access to the stage while it is energized. The System Integrator or qualified installer is responsible for determining and meeting all safety and compliance requirements necessary for the integration of this stage into the final application.



DANGER: Remove power before connecting or disconnecting electrical components or cables. Failure to do so may cause electric shock.



WARNING: The protective ground connection must be properly installed to minimize the possibility of electric shock.



WARNING: Operator access to the base and tabletop must be restricted while connected to a power source. Failure to do so may cause electric shock.



CAUTION: The stage controller must provide over-current and over-speed protection. Failure to do so may result in permanent damage to the motor and stage components.

Table 3-1: Motor Pin Assignments

Pin	Description	Connector
A1	Motor Phase A	
A2	Motor Phase B	
A3	Motor Phase C	
1	Motor Shield (EMI shield)	
2	Reserved	
3	Reserved	
4	Reserved	
5	Reserved	
A4	Frame ground (motor protective ground)	

Mating Connector	Aerotech P/N	Third Party P/N
Backshell	ECK00656	Amphenol #17E-1726-2
Sockets [QTY. 4]	ECK00659	ITT Cannon #DM53744-6
Connector	ECK00657	ITT Cannon #DBMM9W4SA197

Table 3-2: Feedback Pin Assignments

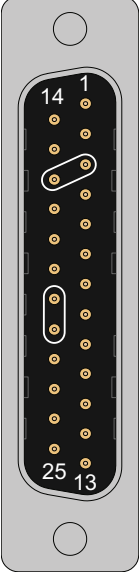
Pin	Description	Connector
1	Signal shield connection	
2	Over-Temperature Thermistor sensor	
3	+5 V power supply	
4	Reserved	
5	Hall Effect sensor, phase B	
6	Marker-N	
7	Marker	
8	Reserved	
9	Reserved	
10	Hall Effect sensor, phase A	
11	Hall Effect sensor, phase C	
12	Signal indicating maximum travel produced by positive/CW stage direction.	
13	Reserved	
14	Cosine	
15	Cosine-N	
16	+5 V power supply	
17	Sine	
18	Sine-N	
19	Reserved	
20	Common ground	
21	Common ground	
22	Reserved	
23	Reserved	
24	Signal indicating maximum travel produced by negative/CCW stage direction.	
25	Reserved	
Case	Signal shield connection (to case)	

Mating Connector	Aerotech P/N	Third Party P/N
Backshell	ECK00656	Amphenol #17E-1726-2
Connector	ECK00300	FCI DB25S064TLF

3.2. Motor and Feedback Wiring

Shielded cables are required for the motor and feedback connections.

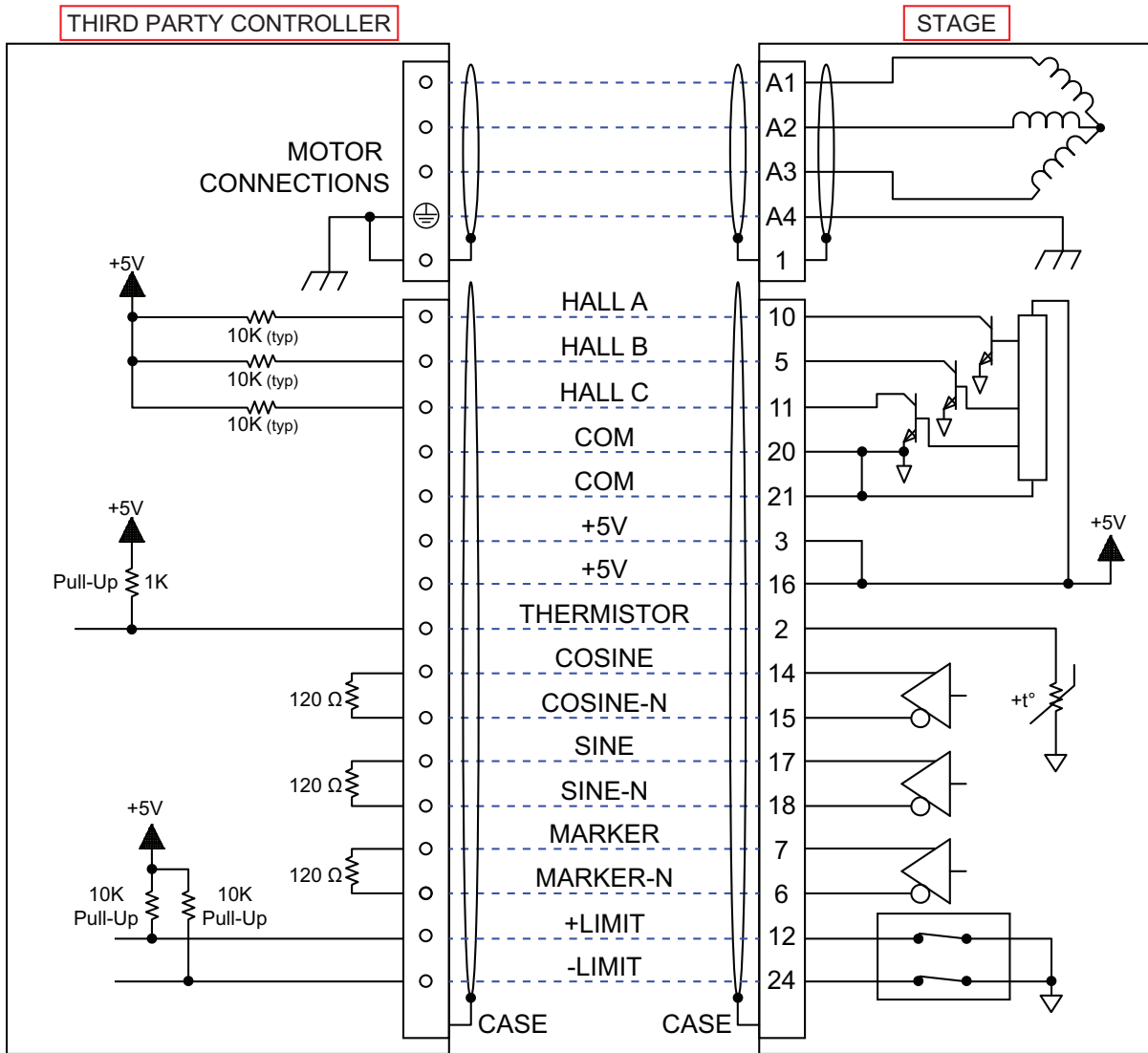

Figure 3-1: Motor and Feedback Wiring

3.3. Motor and Feedback Specifications

Table 3-3: Feedback Specifications

Hall-Effect Sensors Specifications	
Supply Voltage	5 V
Supply Current	50 mA
Output Type	Open Collector
Output Voltage	24 V max (pull up)
Output Current	5 mA (sinking)

Thermistor Specifications	
Polarity	Logic "0" (no fault)
	Logic "1" (over-temperature fault)
Cold Resistance	100 Ω
Hot Resistance	10 K
Note: 1K pull-up to +5V recommended.	

Encoder Specifications	
Supply Voltage	5 V DC \pm 0.25 V
Supply Current	150 mA max
Output Signals	Sinusoidal Type (Incremental Encoder) with Marker <ul style="list-style-type: none"> • Signal-A (COS/COS-): 0.6 - 1.2 V_{ss} • Signal-B (SIN/SIN-): 0.6 - 1.2 V_{ss} • Signal-R (MKR/MKR-): 0.2 - 0.85 V • Signal Period: 20 μm
	NOTES: <ul style="list-style-type: none"> • Sinusoidal encoder signals are optimized at the factory for 1.0 V_{ss}. • Marker encoder signals are optimized at the factory for optimum amplitude and phasing.
	Over-travel Limits <ul style="list-style-type: none"> L1 (-Limit), TTL Output L2 (+Limit), TTL Output
	NOTES: <ul style="list-style-type: none"> • Limit "Not Active" output state = "Active Low" • Limit "Active" output state = "Active High"
NOTE: If the WaferMaxZ is driven beyond the electrical limit, it will encounter a mechanical stop. Impacting the mechanical stop could cause damage to the stage, even at low speeds.	

NOTE: Aerotech continually improves its product offerings; listed options may be superseded at any time. All drawings and illustrations are for reference only and were complete and accurate as of this manual's release. Refer to www.aerotech.com for the most up-to-date information.

Table 3-4: WaferMaxZ Motor Specifications (BLMUC-95 Motor)

		BLMUC-95
Performance Specifications (1)(5)		
Continuous Force, 1.4 bar (20 psi) (2)	N (lb)	40.5 (9.1)
Continuous Force, No Forced Cooling (2)	N (lb)	23.0 (5.2)
Electrical Specifications(5)		
Winding Designation		-A
BEMF Constant (line-line, max)	V/(m/s) (V/(in/s))	9.00 (0.23)
Continuous Current, No Forced Cooling (2)	A_{pk} (A_{rms})	2.94 (2.08)
Peak Current, Stall (3)	A_{pk} (A_{rms})	20.68 (14.62)
Force Constant, Sine Drive (4) (8)	N/A_{pk} (lb/ A_{pk})	7.83 (1.76)
	N/A_{rms} (lb/ A_{rms})	11.07 (2.49)
Motor Constant (2) (4)	N/\sqrt{W} (lb/ \sqrt{W})	3.35 (0.75)
Resistance, 25°C (line-line)	Ω	5.2
Inductance (line-line)	mH	0.70
Thermal Resistance, 1.4 bar (20 psi)	°C/W	0.69
Thermal Resistance, No Forced Cooling	°C/W	2.12
Maximum Bus Voltage	V_{DC}	340
1. Performance is dependent upon heat sink configuration, system cooling conditions, and ambient temperature 2. Values shown @ 100°C rise above a 25°C ambient temperature, with motor mounted to the specified aluminum heat sink. 3. Peak force assumes correct rms current; consult Aerotech. 4. Force constant and motor constant specified at stall 5. All performance and electrical specifications ±10% 6. Maximum winding temperature is 125°C. 7. Ambient operating temperature range 0 °C - 25 °C; consult Aerotech for performance in elevated ambient temperatures 8. All Aerotech amplifiers are rated A_{pk} ; use force constant in $N \cdot m/A_{pk}$ when sizing.		

3.4. Limits, Marker, and Machine Direction

Aerotech stages are configured to have positive and negative "machine" directions. The positive machine direction is also the CW limit direction. The machine direction defines the phasing of the feedback and motor signals and is dictated by the stage wiring (refer to [Section 3.5](#) for Motor and Feedback phasing information). Programming direction of a stage is set by the controller that is used to move the stage. Programming direction is typically selectable in the controller, while machine direction is hardwired in the stage. [Figure 3-2](#) shows the machine direction of WaferMaxZ stages.

The marker for the WaferMaxZ is in the approximate center of travel.

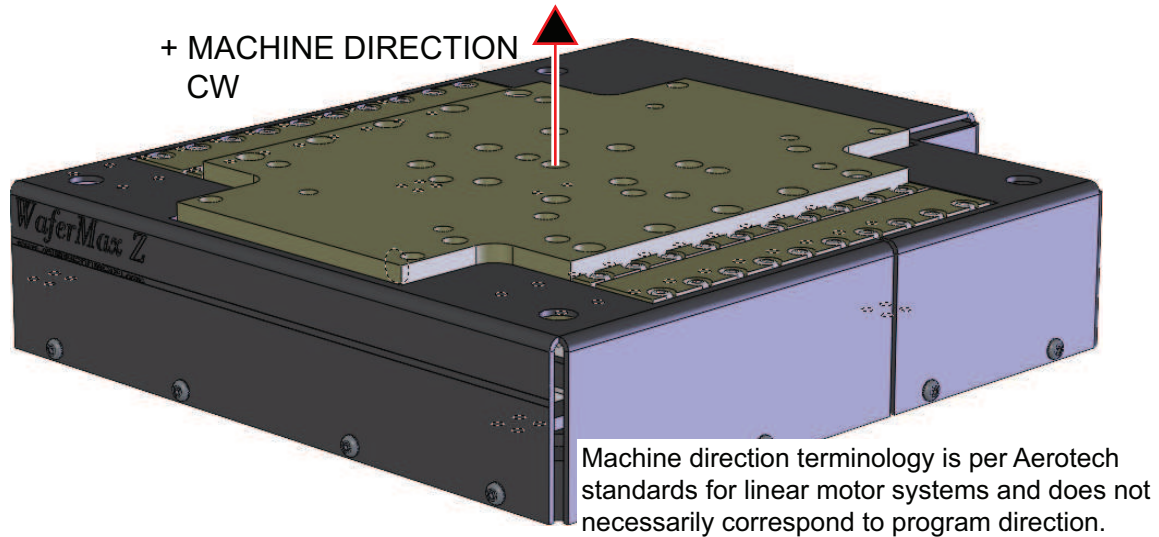

Figure 3-2: Machine Direction

3.5. Motor and Feedback Phasing

Motor phase voltage is measured relative to the virtual wye common point.

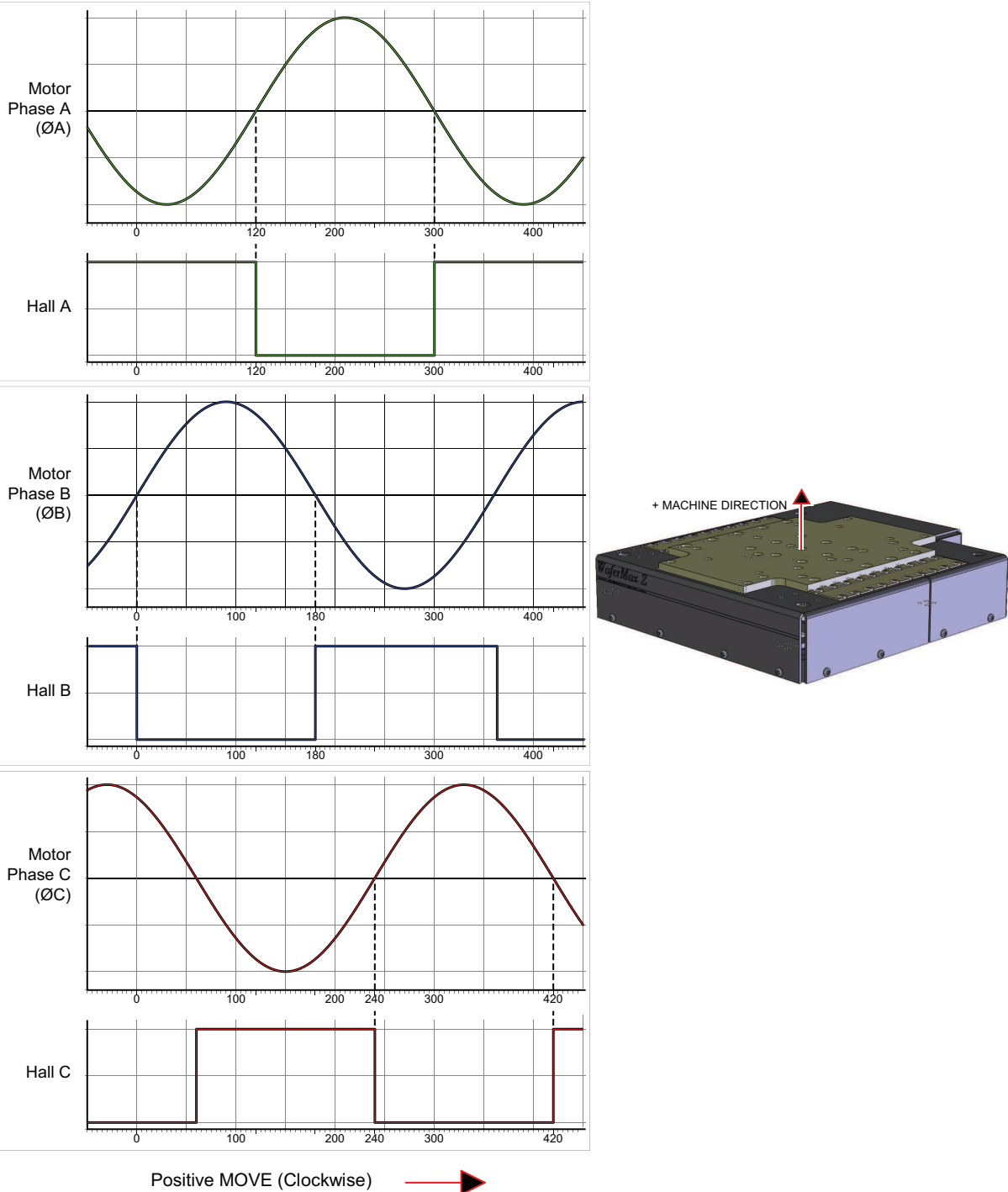

Figure 3-3: Hall Phasing

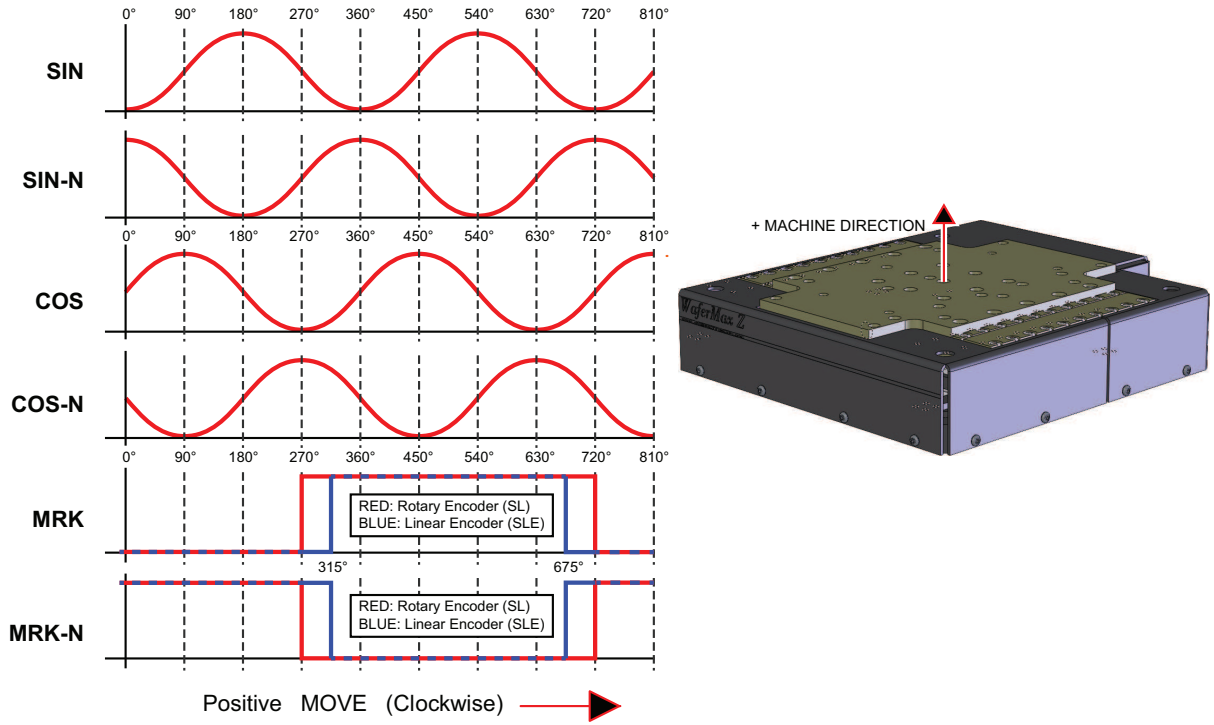

Figure 3-4: Analog Encoder Phasing Reference Diagram

Chapter 4: Maintenance



DANGER: To minimize the possibility of bodily injury or death, disconnect all electrical power prior to performing any maintenance or making adjustments to the equipment.

4.1. Service and Inspection Schedule

Inspect the WaferMaxZ once per month. A longer or shorter inspection interval may be required depending on the specific application, and conditions such as the duty cycle, speed, and environment.

In general, stages operating in a clean environment should be cleaned and lubricated annually or every 500 km (whichever comes first). For stages operating under conditions involving excessive debris, the stage should be cleaned every six months. For high-speed applications (those near max speed at a duty cycle of 50%), frequent maintenance with standard lubricants is required.

Monthly inspections should include but not be limited to:

- Visually inspect the stage and cables
- Re-tighten loose connectors
- Replace or repair damaged cables
- Clean the WaferMaxZ and any components and cables as needed
- Repair any damage before operating the WaferMaxZ
- Inspect and perform an operational check on all safeguards and protective devices

4.2. Cleaning and Lubrication



DANGER: To minimize the possibility of bodily injury or death, disconnect all electrical power prior to performing any maintenance or making adjustments to the equipment.



WARNING: Further disassembly of the stage is not recommended because proper assembly and calibration can only be done at the factory. In addition, a laser interferometer is required for post assembly verification to maintain warranties. Contact Aerotech for more information.

Cleaning

Before using a cleaning solvent on any part of the WaferMaxZ, blow away small particles and dust with nitrogen or, less preferably, clean, dry, compressed air.

Any metal surface on the stage can be cleaned with either acetone or isopropyl alcohol.



WARNING: Make sure that all solvent has completely evaporated before attempting to move the stage.

Lubrication



WARNING: Eye protection must be worn when in the proximity of compressed air components.

NOTE: During the lubrication procedure, inspect the linear motion guides for any damage or signs of wear.

For the cross-roller bearings, use Kluberplex BEM 34-132 grease. Only use the specified grease as other greases may be incompatible.

If the application process uses only a small portion of travel for most of the duty cycle, periodically drive the stage through full travel to redistribute the lubrication in the bearings. The motor is completely non-contact and requires no lubrication.



DANGER: Strong rare-earth magnets are present in the linear motor magnet track. Loose metal objects (tools, watches, keys, etc.) may cause personal injury and/or damage to the equipment.

Lubrication Procedure

1. Disable and then remove power to the stage.
2. Be sure the pressure to the pneumatic counterbalance is still supplied to the stage.
3. Remove the button head screws that attach the outer covers to the stage base and then remove the covers.
4. Remove any accumulated dust or debris from the inside of the assembly.

5. Remove any dirty or dried lubricant from the crossed roller bearing ways. Use a clean, lint-free cloth with a side-to-side motion. Use a swab soaked in Isopropyl Alcohol to remove stubborn debris.
6. Apply a thin, continuous film of lubricant to the linear bearing ways. A good quality, natural bristle artist's brush makes an excellent applicator.
7. Manually move the wedge to the opposite end of travel. This will work the grease into the linear bearings. The stage table should move freely with little resistance.
8. Repeat steps 3 through 5 for any areas covered by the original table position.
9. Refasten the covers
10. Restore power to the stage and drive the stage table back to its original position to redistribute lubricants.

4.3. Flexure Constraints

The WaferMaxZ uses flexures to fix the table top in the X and Y directions. These flexures are vital to the fundamental operation of the stage (refer to [Figure 4-1](#)).

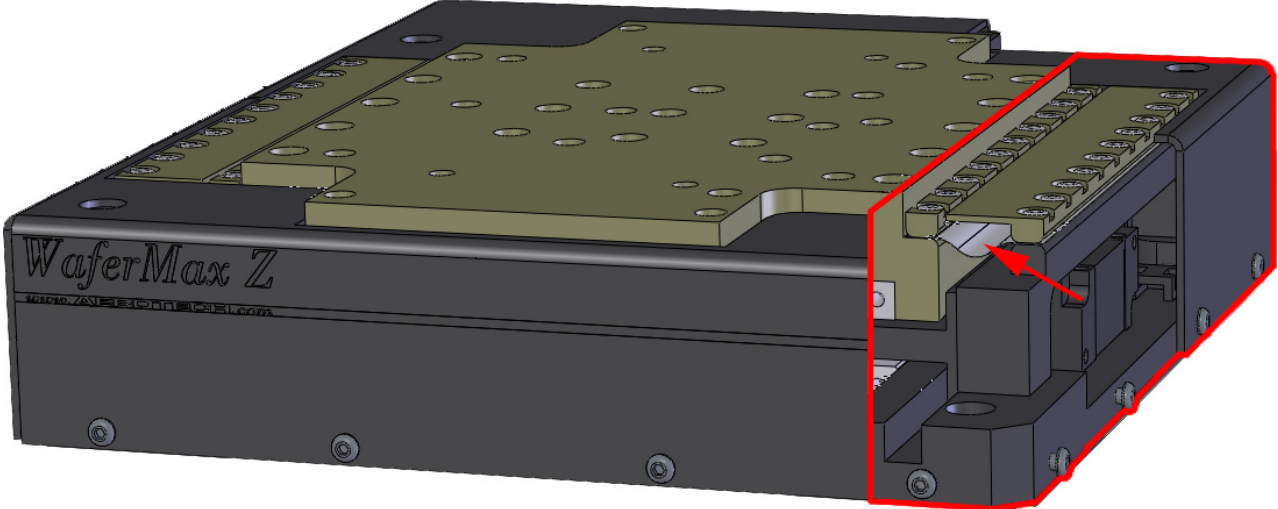

Figure 4-1: Cutaway View of an WaferMaxZ Flexure

The flexures are delicate and must not be tampered with, scratched, or dented. Covers protect the flexures from damage and should be kept in place during normal stage operation.

When the covers are removed during maintenance and servicing, be sure not to damage these flexures. This may cause premature fatigue failure of the flexures due to stress concentration.

4.4. Troubleshooting

Symptom	Possible Cause and Solution
Stage will not move	<ul style="list-style-type: none">• In Limit condition. Check limits (refer to Chapter 3) and refer to controller documentation for polarity and compatibility requirements (Example: voltage requirements).• Controller trap or fault (refer to controller documentation).• Stage cables not connected (or incorrectly connected) to controller (refer to system documentation).
Stage moves uncontrollably	<ul style="list-style-type: none">• Encoder (sine and cosine) signal connections (refer to Chapter 3 and Controller documentation).• Motor Connections (refer to Chapter 3 and Controller documentation).
Stage oscillates or squeals	<ul style="list-style-type: none">• Gains misadjusted (refer to the controller documentation).• Encoder signals (refer to the controller documentation).

This page intentionally left blank.

Appendix A: Warranty and Field Service

Aerotech, Inc. warrants its products to be free from harmful defects caused by faulty materials or poor workmanship for a minimum period of one year from date of shipment from Aerotech. Aerotech's liability is limited to replacing, repairing or issuing credit, at its option, for any products that are returned by the original purchaser during the warranty period. Aerotech makes no warranty that its products are fit for the use or purpose to which they may be put by the buyer, whether or not such use or purpose has been disclosed to Aerotech in specifications or drawings previously or subsequently provided, or whether or not Aerotech's products are specifically designed and/or manufactured for buyer's use or purpose. Aerotech's liability on any claim for loss or damage arising out of the sale, resale, or use of any of its products shall in no event exceed the selling price of the unit.

THE EXPRESS WARRANTY SET FORTH HEREIN IS IN LIEU OF AND EXCLUDES ALL OTHER WARRANTIES, EXPRESSED OR IMPLIED, BY OPERATION OF LAW OR OTHERWISE. IN NO EVENT SHALL AEROTECH BE LIABLE FOR CONSEQUENTIAL OR SPECIAL DAMAGES.

Return Products Procedure

Claims for shipment damage (evident or concealed) must be filed with the carrier by the buyer. Aerotech must be notified within thirty (30) days of shipment of incorrect material. No product may be returned, whether in warranty or out of warranty, without first obtaining approval from Aerotech. No credit will be given nor repairs made for products returned without such approval. A "Return Materials Authorization (RMA)" number must accompany any returned product(s). The RMA number may be obtained by calling an Aerotech service center or by submitting the appropriate request available on our website (www.aerotech.com). Products must be returned, prepaid, to an Aerotech service center (no C.O.D. or Collect Freight accepted). The status of any product returned later than thirty (30) days after the issuance of a return authorization number will be subject to review.

Visit <https://www.aerotech.com/global-technical-support.aspx> for the location of your nearest Aerotech Service center.

Returned Product Warranty Determination

After Aerotech's examination, warranty or out-of-warranty status will be determined. If upon Aerotech's examination a warranted defect exists, then the product(s) will be repaired at no charge and shipped, prepaid, back to the buyer. If the buyer desires an expedited method of return, the product(s) will be shipped collect. Warranty repairs do not extend the original warranty period.

Fixed Fee Repairs - Products having fixed-fee pricing will require a valid purchase order or credit card particulars before any service work can begin.

All Other Repairs - After Aerotech's evaluation, the buyer shall be notified of the repair cost. At such time the buyer must issue a valid purchase order to cover the cost of the repair and freight, or authorize the product(s) to be shipped back as is, at the buyer's expense. Failure to obtain a purchase order number or approval within thirty (30) days of notification will result in the product(s) being returned as is, at the buyer's expense.

Repair work is warranted for ninety (90) days from date of shipment. Replacement components are warranted for one year from date of shipment.

Rush Service

At times, the buyer may desire to expedite a repair. Regardless of warranty or out-of-warranty status, the buyer must issue a valid purchase order to cover the added rush service cost. Rush service is subject to Aerotech's approval.

On-site Warranty Repair

If an Aerotech product cannot be made functional by telephone assistance or by sending and having the customer install replacement parts, and cannot be returned to the Aerotech service center for repair, and if Aerotech determines the problem could be warranty-related, then the following policy applies:

Aerotech will provide an on-site Field Service Representative in a reasonable amount of time, provided that the customer issues a valid purchase order to Aerotech covering all transportation and subsistence costs. For warranty field repairs, the customer will not be charged for the cost of labor and material. If service is rendered at times other than normal work periods, then special rates apply.

If during the on-site repair it is determined the problem is not warranty related, then the terms and conditions stated in the following "On-Site Non-Warranty Repair" section apply.

On-site Non-Warranty Repair

If any Aerotech product cannot be made functional by telephone assistance or purchased replacement parts, and cannot be returned to the Aerotech service center for repair, then the following field service policy applies:

Aerotech will provide an on-site Field Service Representative in a reasonable amount of time, provided that the customer issues a valid purchase order to Aerotech covering all transportation and subsistence costs and the prevailing labor cost, including travel time, necessary to complete the repair.

Service Locations

<http://www.aerotech.com/contact-sales.aspx?mapState=showMap>

USA, CANADA, MEXICO Aerotech, Inc. Global Headquarters Phone: +1-412-967-6440 Fax: +1-412-967-6870	CHINA Aerotech China Full-Service Subsidiary Phone: +86 (21) 3319 7715	GERMANY Aerotech Germany Full-Service Subsidiary Phone: +49 (0)911 967 9370 Fax: +49 (0)911 967 93720
JAPAN Aerotech Japan Full-Service Subsidiary Phone: +81 (0)50 5830 6814 Fax: +81 (0)43 306 3773	TAIWAN Aerotech Taiwan Full-Service Subsidiary Phone: +886 (0)2 8751 6690	UNITED KINGDOM Aerotech United Kingdom Full-Service Subsidiary Phone: +44 (0)1256 855055 Fax: +44 (0)1256 855649

Have your customer order number ready before calling.

Appendix B: Revision History

Revision	Description
1.01.00	<ul style="list-style-type: none">• Product Update• Updated product specifications: Table 1-3• Updated Dimensions: Section 2.2.• Updated Counterbalance Setup: Section 2.6.
1.00.00	New Manual

This page intentionally left blank.

Index

		Humidity	10
	2		
2010		6	
	A		
Accuracy		10-11	
Altitude		10	
Ambient Temperature		10	
Attaching the Payload to the Stage		17	
	B		
Bidirectional		11	
BLMUC-95		29	
Bus Voltage		11	
	C		
Cleaning		34	
cleaning solvent		34	
Continuous Current		11	
	D		
Digital Output Encoder		28	
	E		
Electrical Installation		23	
EN 60204-1		6	
EN ISO 12100		6	
Encoder		11	
Encoder Specifications		28	
	F		
Finish		11	
	G		
Global Technical Support		2	
grease		34	
	H		
Hall-Effect Sensors Specifications		28	
Handling the Stage		13	
			I
		Incremental Encoder	28
		inspect	33
		Inspection Schedule	33
			K
		Kluberplex BEM 34-132	34
			L
		label	13
		Load	11
		Load Capability	17
		Lubrication	34
		Lubrication Procedure	34
			M
		Material	11
		Maximum Load	11
		Motor Specifications	29
		Motor Type	11
		mounting surface	15
		Mounting Surface	15
		Moving Mass	11
			N
		nitrogen	19
			P
		part number	13
		Payload	17
		Pitch	11
		Protection Rating	10
		protective ground connection	24
			R
		Repeatability	11
		Resolution	11

Roll	11
Rotary Encoder	28
S	
Securing the Stage to the Mounting Surface	15
serial number	13
Service and Inspection Schedule	33
Shimming	15
Speed	11
stabilize	13
stage distortion	15
Stage Mass	11
Straightness	11
Support	2
T	
Technical Support	2
Temperature	10
Thermistor Specifications	28
Travel	11
U	
Unpacking and Handling the Stage	13
V	
Vibration	10
W	
Warranty and Field Service	39
Wedge Ratio	11
Y	
Yaw	11