

AVS100/AVSI100 Series

Mechanical-Bearing Screw-Driven Lift Stage

Long-life linear guide bearing system

Submicron closed-loop positioning

Low-cost, high-performance stage

6, 13, and 25 mm travel models

Precision-ground ball screw

Integral or removable motor



Aerotech's AVS100/AVSI100 series stages offer a solution for applications that require very small incremental movements in elevation above a horizontal plane. Low profiles and precise motion capability make these stages ideal for use in semiconductor wafer inspection and testing, fiberoptics assembly and inspection, automated tool alignment, machine vision inspection systems, and laser machining applications.

The AVSI100 series stages provide identical performance to the AVS100 stages, but in an even smaller footprint. The AVSI100 integrates the motor directly with the drive screw with no motor coupling. This makes the stage significantly shorter in length.

Quality Design Provides Superior Performance

The AVS100/AVSI100 series provides precise elevation of a load in a vertical plane. Rotational movement of a precision-ground ballscrew is converted into vertical elevation of the AVS100/AVSI100 series tabletop.

Sealed linear motion guide bearings with integral wipers are incorporated to provide excellent payload capability, long life, and smooth, precision motion. Stable and parallel vertical motion with no rocking or horizontal deviation of the platform is ensured.

Careful mechanical design allows the AVS100/AVSI100 series to achieve submicron resolution and still maintain a compact profile. The optional HALAR factory calibration option is available to further increase standard accuracy and repeatability.

A Better Approach to Vertical Motion

The vertical lift approach offers an alternative to traditional Z-plane oriented stages. Not only do the AVS100/AVSI100 series stages offer a lower profile, but the load can also be accessed easily from any side. And by centering the payload over the bearings, there are no cantilevering effects. The AVS100/AVSI100 series stages provide a space-saving alternative to traditional XYZ systems and are equally suited to laboratory and industrial applications. Optional stage finishes are available for various environments, including vacuum preparation.

Additional Standard Features

All AVS100/AVSI100 series stages are equipped standard with integral limit switches and mechanical hard stops. The stage tabletop is treated with a Teflon®-impregnated hardcoat (Rockwell 62 hardness) that is scratch-resistant and provides outstanding protection in the harshest environments. The stage itself has a black anodize finish.

Motor and Drives

The AVS100/AVSI100 series includes Aerotech's high performance NEMA 23 frame-size BMS series brushless, slotless servomotor. The slotless motor has zero cogging and therefore is optimized for applications requiring very smooth motion.

Aerotech manufactures a wide range of matching drives and controls to provide a fully integrated and optimized motion solution.

AVS100/AVSI100 Series SPECIFICATIONS

Basic Model		AVS100-06/AVSI100-06	AVS100-13/AVSI100-13	AVS100-25/AVSI100-25
Travel		6 mm	13 mm	25 mm
Drive System		Precision Ball Screw/Brushless Servomotor		
Bus Voltage		Up to 160 VDC		
Continuous Current	A _{pk}	2.3 A		
	A _{rms}	1.6 A		
Resolution	with 1000-line TTL encoder	0.53 μm @ 4000 steps/rev motor resolution		
	with 1000-line 1 Vpp encoder	5.3 nm - 0.106 μm		
	with 2500-line TTL encoder	0.2 μm @ 10,000 steps/rev motor resolution		
Maximum Travel Speed		50 mm/s		
Effective Lead		2.12 mm/rev		
Maximum Load ⁽¹⁾		25.0 kg		
Accuracy	Uncalibrated	±1.5 μm	±3.0 μm	±5.0 μm
	Calibrated ⁽²⁾	±1.0 μm		
Repeatability (Bidirectional)	Uncalibrated	±1.0 μm		
	Calibrated ⁽²⁾	±0.75 μm		
Straightness and Flatness (Maximum Deviation)		±1.5 μm	±3.0 μm	±5.0 μm
Pitch and Roll		±5 arc sec	±7.5 arc sec	±10 arc sec
Nominal Stage Weight (With Motor)		4.1 kg	6.1 kg	10.5 kg
Construction		Aluminum/Black Anodize/Hardcoat Table		

Notes:

1. Higher load possible with larger motor on the AVS series stage.
2. Requires Aerotech controller.
3. Specifications are for single-axis systems, measured 50 mm above the tabletop. Performance of multi-axis systems is payload and workpoint dependent. Consult factory for multi-axis or non-standard applications.
4. For inverted operation, consult factory.

AVS100-06/AVSI100-06 DIMENSIONS

AVS100-06

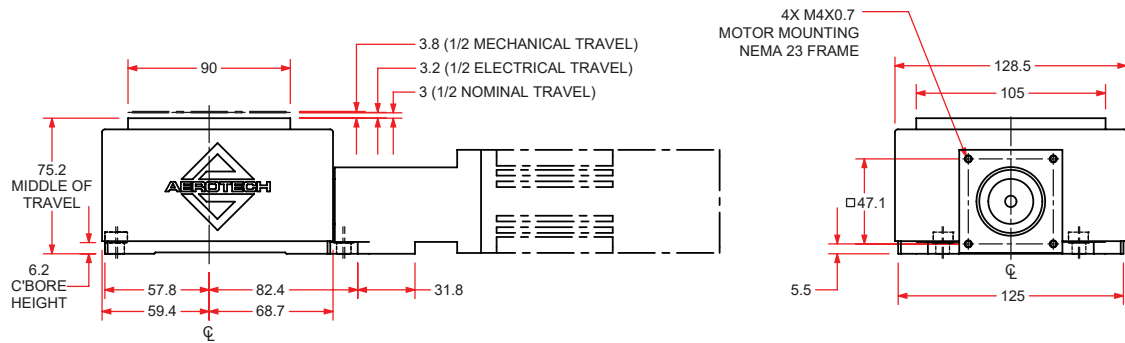
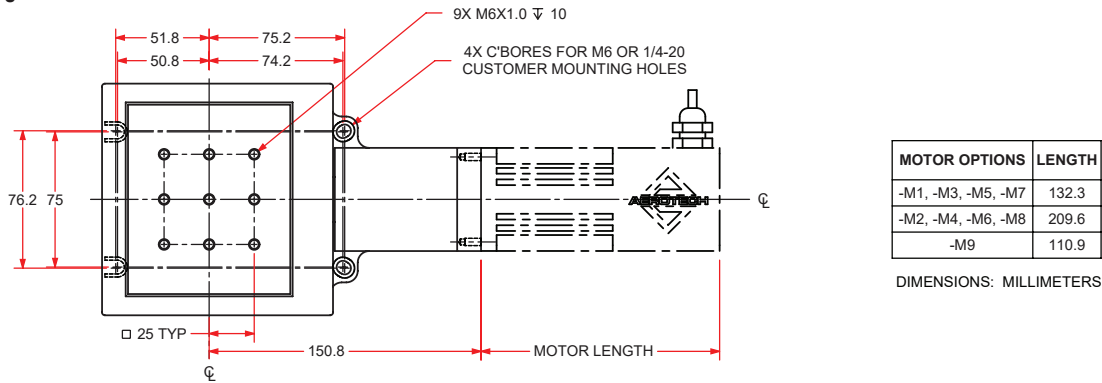

AVSI100-06

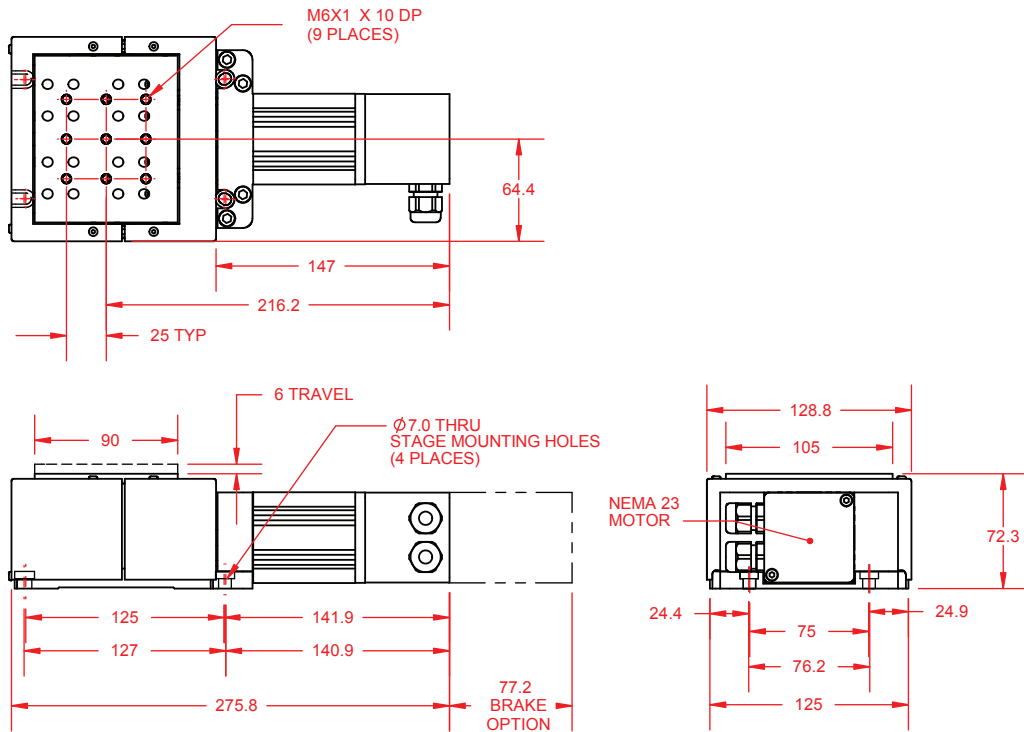

AVS100-13/AVSI100-13 DIMENSIONS

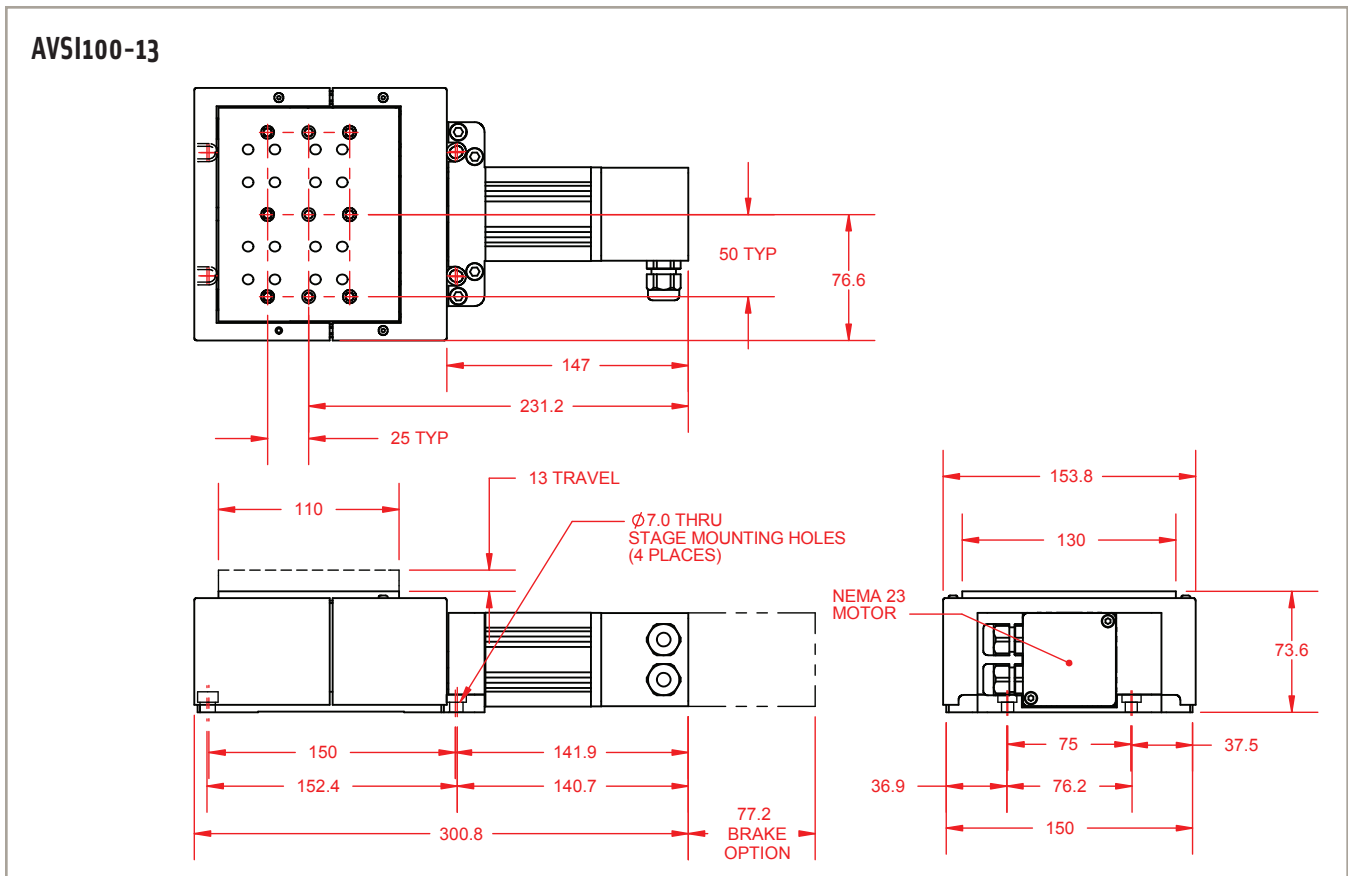
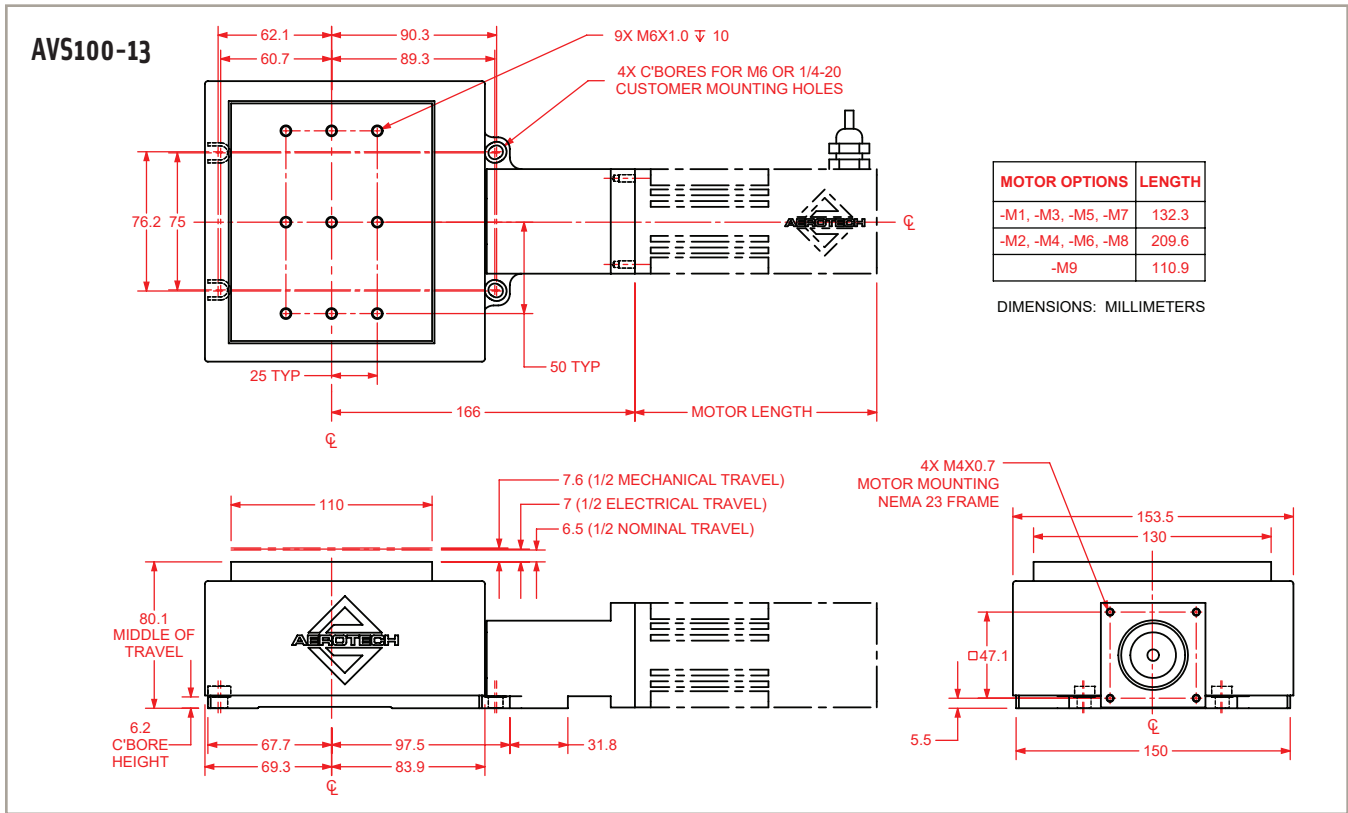

AVS100-25/AVSI100-25 DIMENSIONS

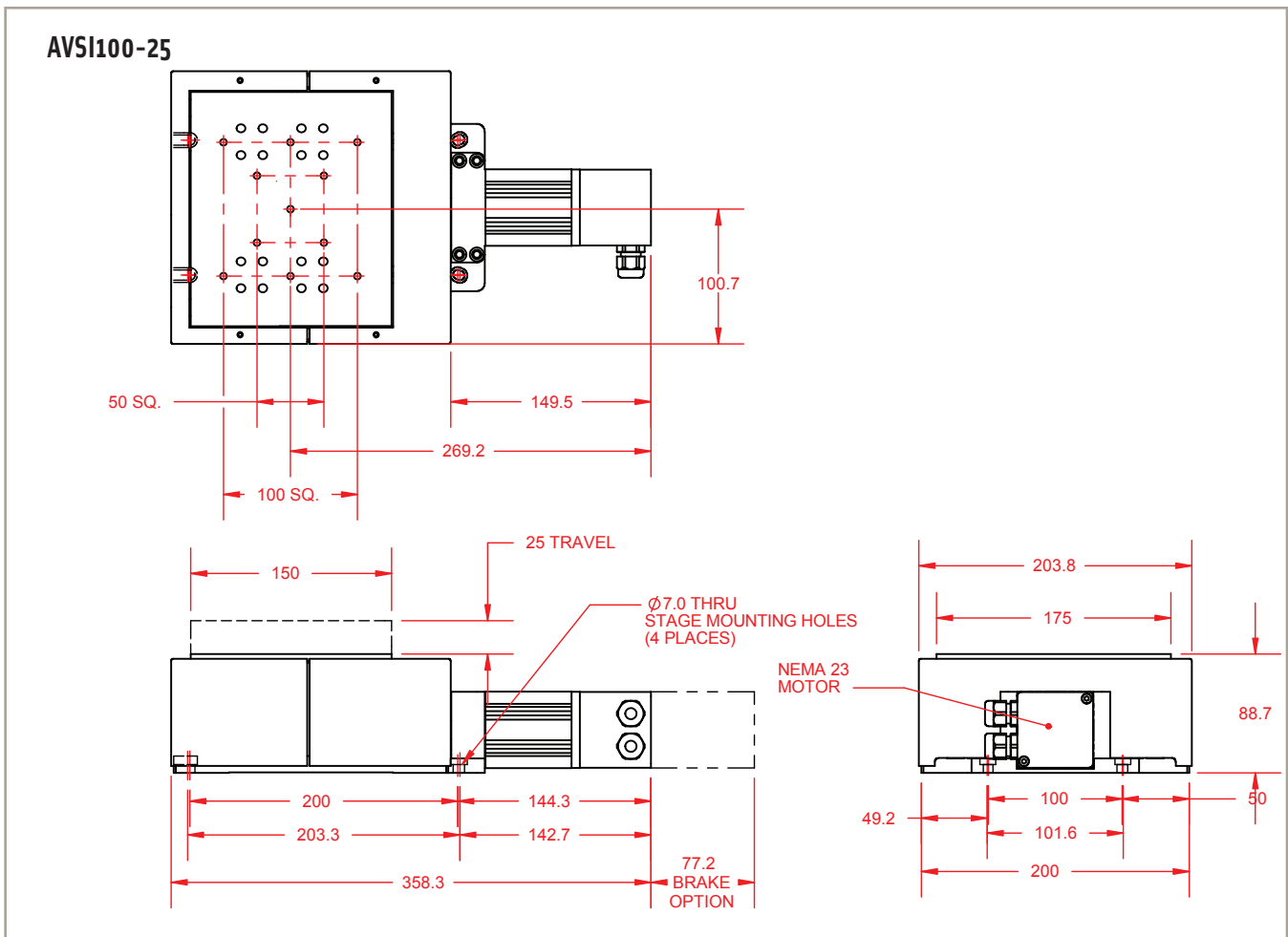
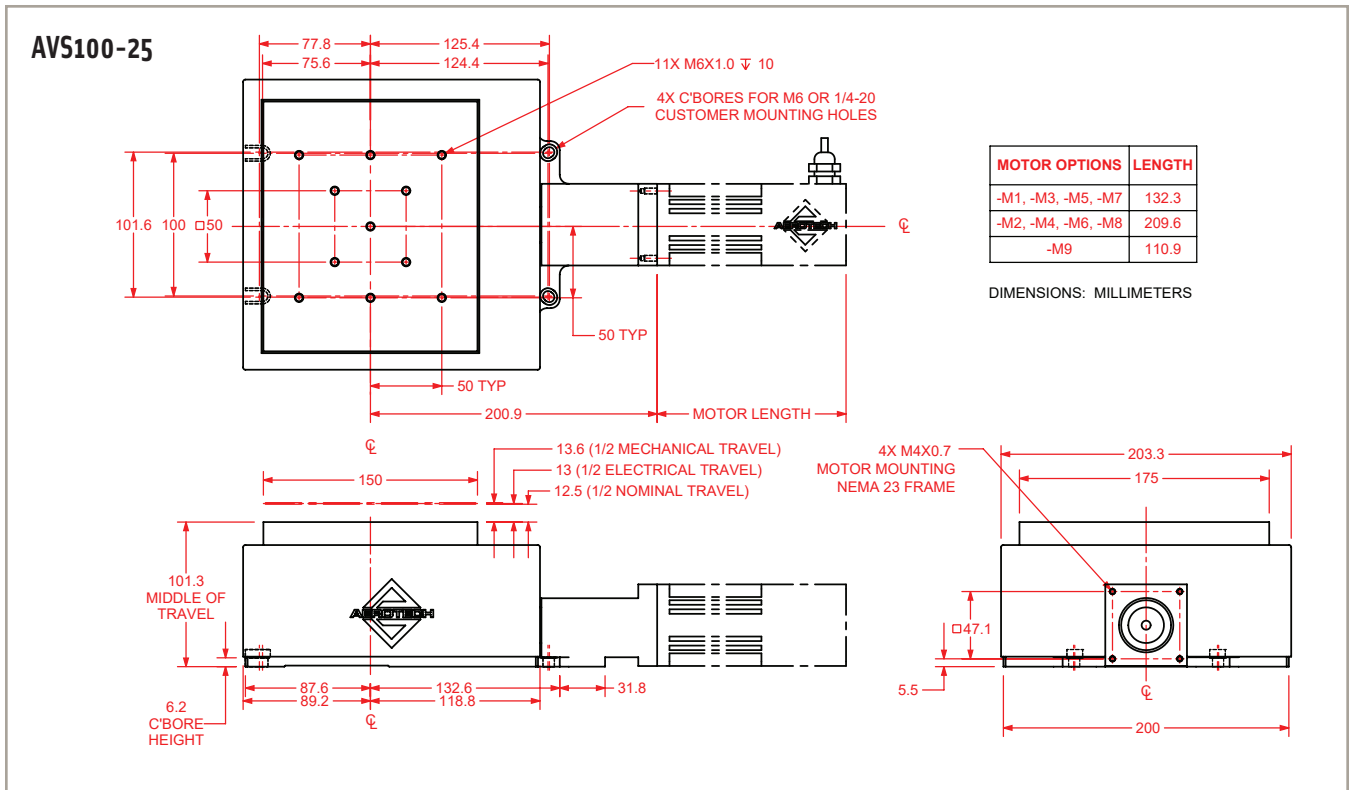

AVS100 Series ORDERING INFORMATION

Travel (Required)

-06	6 mm Travel
-13	13 mm Travel
-25	25 mm Travel

Motor (Optional)

-M1	BMS60 Servo Motor with 2500-Line TTL Encoder
-M2	BMS60 Servo Motor with 2500-Line TTL Encoder and Holding Brake
-M3	BMS60 Servo Motor with 1000-Line 1 Vpp Encoder
-M4	BMS60 Servo Motor with 1000-Line 1 Vpp Encoder and Holding Brake
-M5	BM75 Servo Motor with 2500-Line TTL Encoder
-M6	BM75 Servo Motor with 2500-Line TTL Encoder and Holding Brake
-M7	BM75 Servo Motor with 1000-Line 1 Vpp Encoder
-M8	BM75 Servo Motor with 1000-Line 1 Vpp Encoder and Holding Brake
-M9	SM60 High-Voltage Stepper Motor

Foldback (Optional)

-FB1	Motor Foldback Kit for .250 Inch Diameter Shaft
-FB2	Motor Foldback Kit with Brake for .250 Inch Diameter Shaft

Motor Orientation (Optional)

-2	Bottom Cable Exit
-3	Left-Side Cable Exit (Standard)
-4	Top Cable Exit
-5	Right-Side Cable Exit
-8	Right-Side Foldback
-12	Left-Side Foldback

Limits (Required)

-LI1	Normally-Closed Limit Switches, 9-Pin D Connector
-LI2	Normally-Closed Limit Switches, Flying Leads
-LI3	Normally-Open Limit Switches, 9-Pin D Connector
-LI4	Normally-Open Limit Switches, Flying Leads

Coupling (Optional)

-CP1	Coupling for 0.250 Inch Diameter Shaft
-CP2	Coupling for 0.375 Inch Diameter Shaft

Metrology (Required)

-PL1	Metrology, Uncalibrated with Performance Plots
-PL2	Metrology, Calibrated (HALAR) with Performance Plots

Integration (Required)

Aerotech offers both standard and custom integration services to help you get your system fully operational as quickly as possible. The following standard integration options are available for this system. Please consult Aerotech if you are unsure what level of integration is required, or if you desire custom integration support with your system.

-TAS	<p>Integration - Test as system</p> <p>Testing, integration, and documentation of a group of components as a complete system that will be used together (ex: drive, controller, and stage). This includes parameter file generation, system tuning, and documentation of the system configuration.</p>
-TAC	<p>Integration - Test as components</p> <p>Testing and integration of individual items as discrete components. This is typically used for spare parts, replacement parts, or items that will not be used or shipped together (ex: stage only). These components may or may not be part of a larger system.</p>

AVS100 Series ORDERING INFORMATION

Travel (Required)

-06	6 mm Travel
-13	13 mm Travel
-25	25 mm Travel

Motor (Optional)

-M1	BMS60 Servo Motor with 2500-Line TTL Encoder
-M2	BMS60 Servo Motor with 2500-Line TTL Encoder and Holding Brake
-M3	BMS60 Servo Motor with 1000-Line 1 Vpp Encoder
-M4	BMS60 Servo Motor with 1000-Line 1 Vpp Encoder and Holding Brake

Motor Orientation (Optional)

-3	Left-Side Cable Exit (Standard)
-5	Right-Side Cable Exit

Limits (Required)

-LI1	Normally-Closed Limit Switches, 9-Pin D Connector
-LI3	Normally-Open Limit Switches, 9-Pin D Connector

Metrology (Required)

-PL1	Metrology, Uncalibrated with Performance Plots
-PL2	Metrology, Calibrated (HALAR) with Performance Plots

Integration (Required)

Aerotech offers both standard and custom integration services to help you get your system fully operational as quickly as possible. The following standard integration options are available for this system. Please consult Aerotech if you are unsure what level of integration is required, or if you desire custom integration support with your system.

-TAS	<p>Integration - Test as system</p> <p>Testing, integration, and documentation of a group of components as a complete system that will be used together (ex: drive, controller, and stage). This includes parameter file generation, system tuning, and documentation of the system configuration.</p>
-TAC	<p>Integration - Test as components</p> <p>Testing and integration of individual items as discrete components. This is typically used for spare parts, replacement parts, or items that will not be used or shipped together (ex: stage only). These components may or may not be part of a larger system.</p>