

# ROTARY STAGES **CCS SERIES**



*CCS features a unique collet-chuck design that allows workpiece advance without manual realignment.*

Aerotech's CCS series rotary stages (patent pending) with integrated captured collet chucks provide automated material handling capability for a wide range of materials and applications.

#### **High Precision C/D Collets**

The collet chucks on the CCS family of stages accept C (for CCS190DR) or D-style/Levin (for CCS130DR) collets. These collets are readily available from machine-tool component suppliers in sizes that support tube diameters from 0.1 mm to 27 mm and provide outstanding run-out characteristics for applications requiring high-precision gripping of tubular material.

#### **Captured Collet Design**

CCS features a unique collet-chuck design that allows workpiece advance without manual realignment to compensate for axial tube motion during clamp/unclamp cycles. By moving the taper around the collet instead of drawing the collet into the taper, axial motion of the workpiece is significantly reduced, eliminating the need for part re-registration after tube advancement.

#### **Wet-Cut Features**

The CCS family is designed with mounting features on the

housing to support customer supplied wet-cutting accessories. In addition, the stage is designed to tolerate moderate fluid leakage into the aperture, which is inevitable during wet-cutting operations, to prevent encoder contamination and collet-chuck failure.

#### **Brushless Direct-Drive**

To maximize positioning performance the CCS series uses direct-drive brushless motor technology. Direct-drive technology is optimized for 24/7 production environments, with no brushes to replace and no gear trains or belts to maintain. Direct-drive also provides quicker acceleration and higher top speeds than gear- or belt-driven mechanisms, yielding higher total overall throughput.

The low maintenance, high throughput characteristics of the CCS coupled with the integral material handling capability provide the lowest total cost of ownership when compared to component-level solutions.

## — PRODUCT HIGHLIGHTS —

Integral pneumatic collet chuck

Captive collet design minimizes axial tube motion during clamp/unclamp cycles

Clear aperture for product feed-through

Integral mounting features support customer-supplied wet-cutting accessories

Direct-drive brushless motor and encoder

## CCS Series Specifications

Mechanical Specifications		CCS130DR-160	CCS190DR-240	CCS190DR-260
Travel		±360° continuous		
Accuracy <sup>1</sup>		5 arc sec		
Bidirectional Repeatability		2 arc sec		
Maximum Speed <sup>2</sup>		1000 rpm	600 rpm	
Aperture <sup>3</sup>		7.9 mm (Dry); 3 mm (Wet)	13 mm	26.5 mm
Maximum Torque (Continuous)		0.48 N·m	2.85 N·m	5.06 N·m
Load Capacity <sup>4</sup>	Radial	2 kg	10 kg	15 kg
	Axial	0.50 kg	5 kg	10 kg
	Moment	0.75 N·m	6 N·m	12 N·m
Rotary Inertia (Unloaded)		0.0004 kg·m <sup>2</sup>	0.0039 kg·m <sup>2</sup>	0.0051 kg·m <sup>2</sup>
Stage Mass		3.1 kg	12 kg	14.1 kg
Material		Hardcoat/Anodized Aluminum; Hardened Stainless Steel (Collet Chuck)		
MTBF (Mean Time Between Failure)		10,000 hours		
Collet Type		Type D (Louis Levin & Sons™) Normally-Open	3C	5C
Collet Runout <sup>5</sup>		<30 μm	<25 μm	<20 μm
System Air Pressure <sup>6,7,8</sup>		100 psig	20-100 psig	0-80 psig

1 Calibrated accuracy; requires the use of Aerotech controls and angular programming units.

2 Maximum speed listed is stage and motor dependent (assuming a 340 V bus). Actual speed may be lower due to motor back emf. Consult Aerotech for more details.

3 Dry-Cutting (no ring seal installed) on a system with the -WCUT option limits tube size to 6.7 mm. Wet-cutting (ring-seal required and installed) on a system with the -WCUT option limits tube size to 3.0 mm

4 Maximum loads are mutually exclusive. Loading limits are due to the collet chuck mechanism. Contact Aerotech directly if part load requirement exceeds specifications.

5 TIR of precision gage pin in an ultra-precision collet. Measured 3 mm away from collet face at 80 psig applied air pressure for CCS130DR. Measured 6 mm away from collet face at 40 psig applied air pressure for CCS190DR.

6 The CCS190DR-260 and CCS190DR-240 contain a double-acting collet mechanism that requires air to open and close the collet chuck. Aerotech recommends compressed air filtered to 1 micron particle size or better.

7 The CCS130DR-160 contains a collet chuck mechanism that is normally-open. Collet mechanism requires air to close collet chuck. Air supply must be dry (0° F dew point), oil-less air or 99.99% pure nitrogen. Air or nitrogen must be filtered to 1 micron particle size or better.

8 Exceeding the maximum system air pressure on the CCS190 stages is not recommended and could cause damage and/or performance degradation.

# CCS Series Dimensions

CCS130DR-160

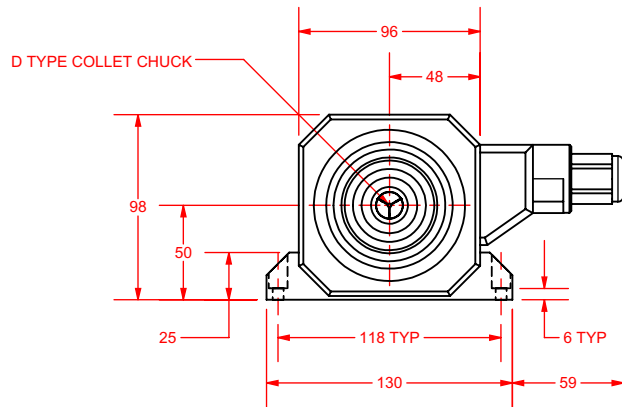
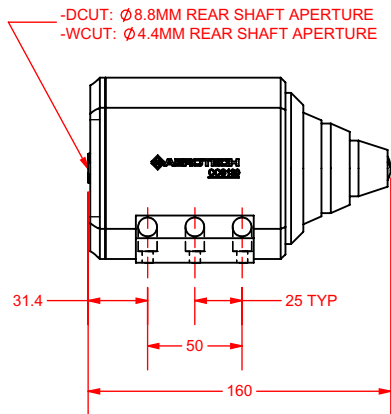
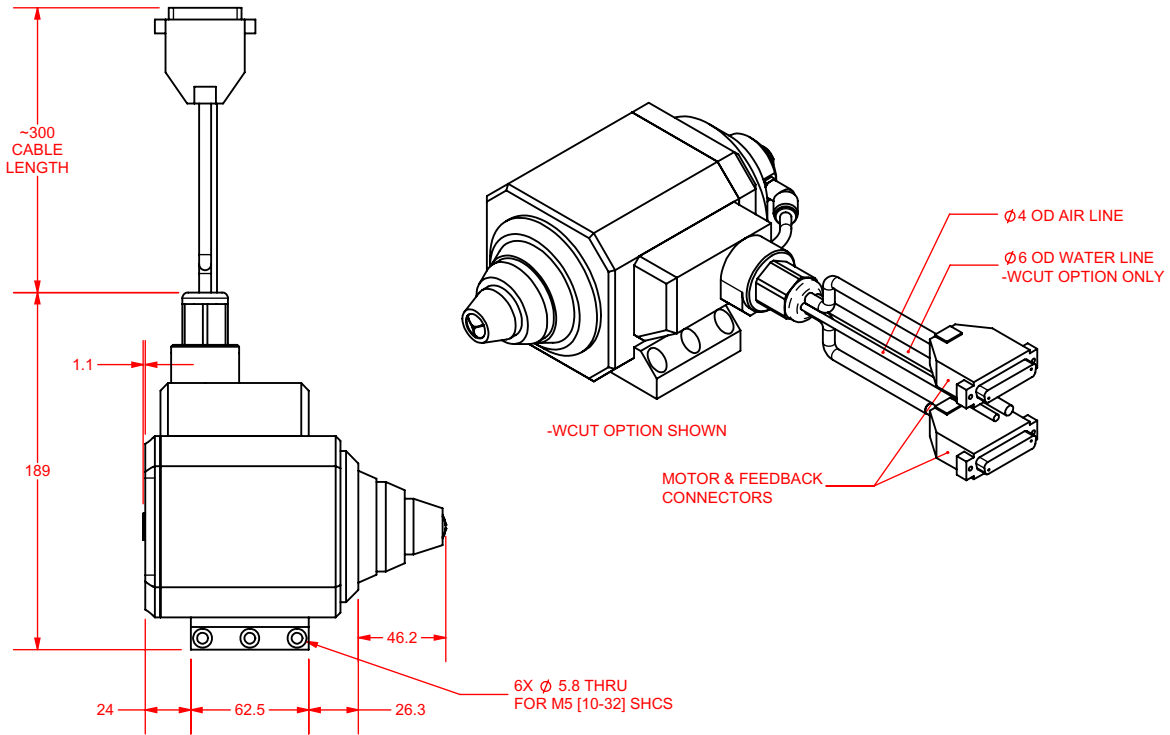

-WCUT (WET CUT OPTION)

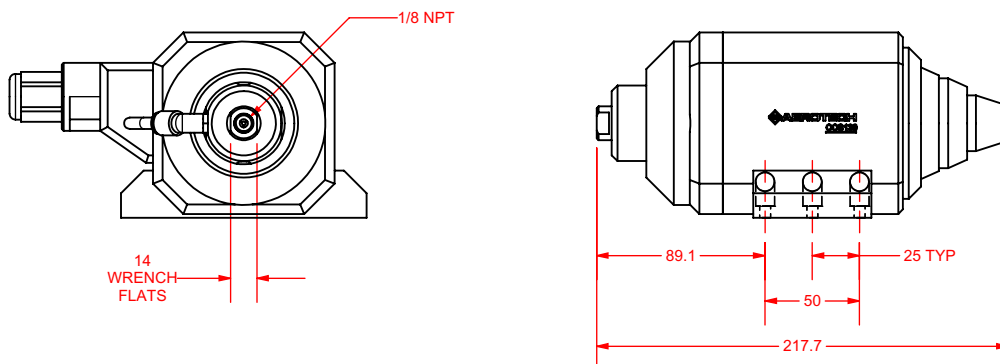

DIMENSIONS: MILLIMETERS

# CCS Series Dimensions

CCS190DR-240

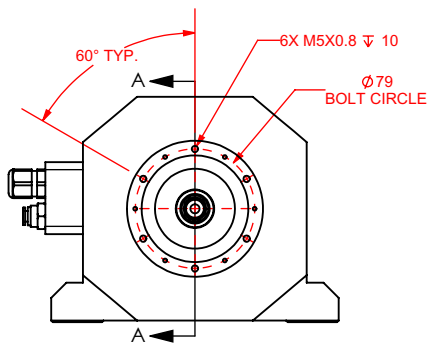
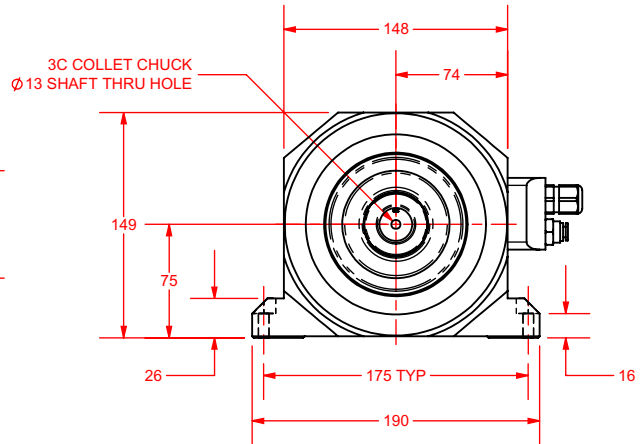
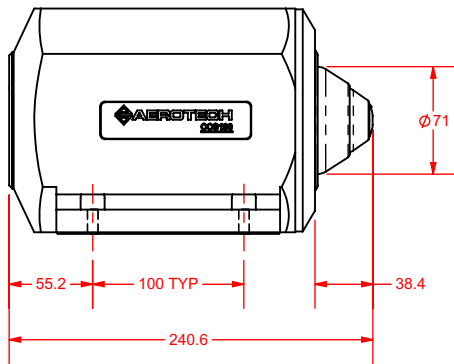
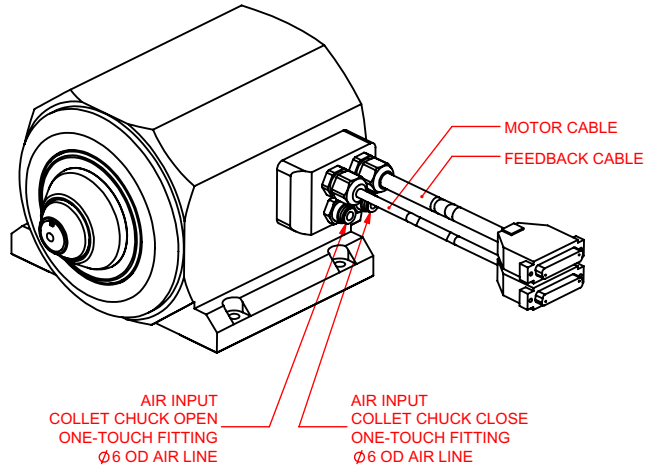
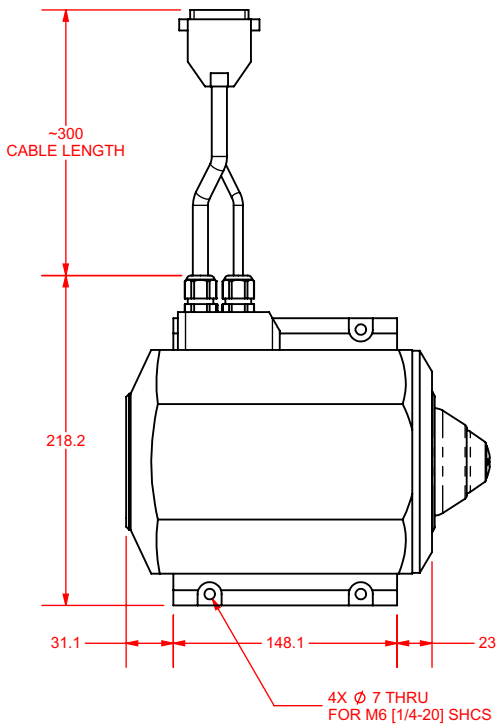

STAGE REAR, REAR COVER REMOVED  
BOLT PATTERN FOR  
WET-CUT ACCESSORY MOUNTING

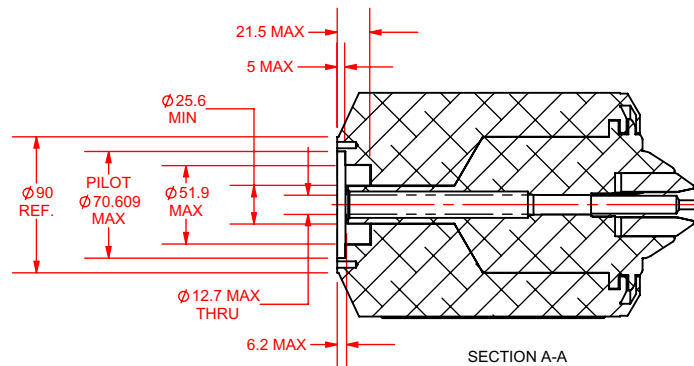

SECTION A-A  
ENVELOPE LIMITS FOR  
WET-CUT ACCESSORY

DIMENSIONS: MILLIMETERS

# CCS Series Dimensions

CCS190DR-260

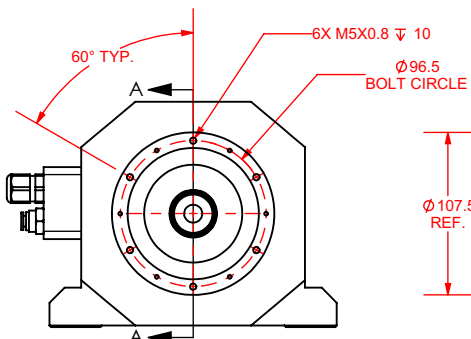
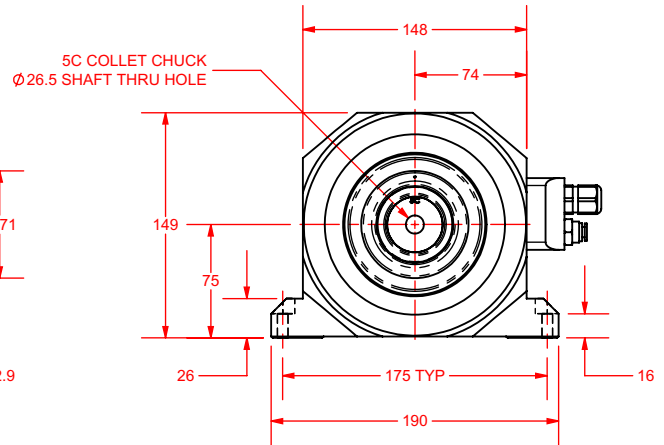
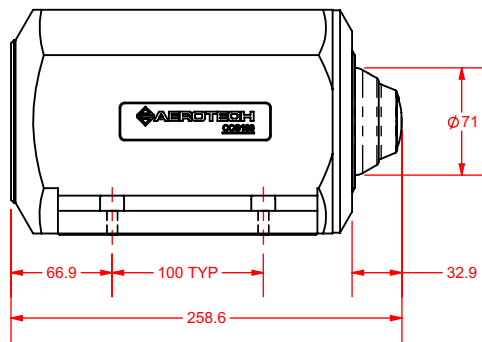
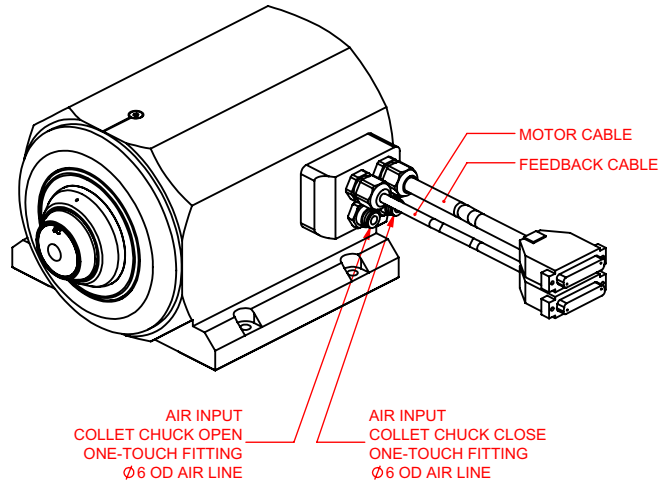
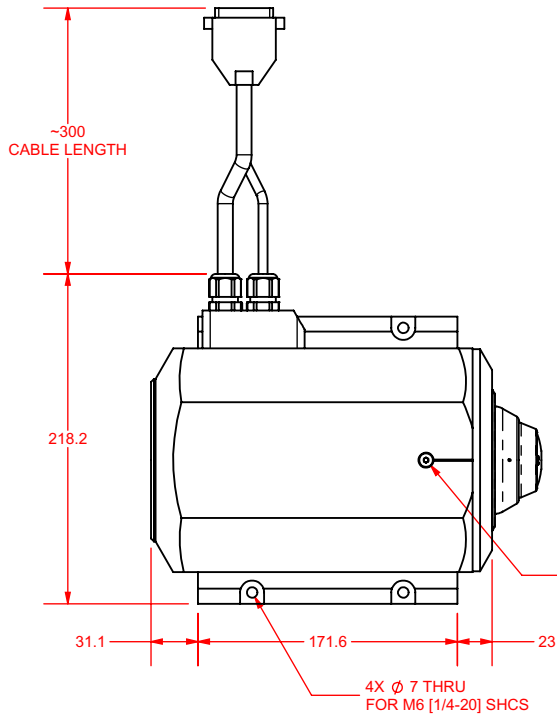

STAGE REAR, REAR COVER REMOVED  
BOLT PATTERN FOR  
WET-CUT ACCESSORY MOUNTING

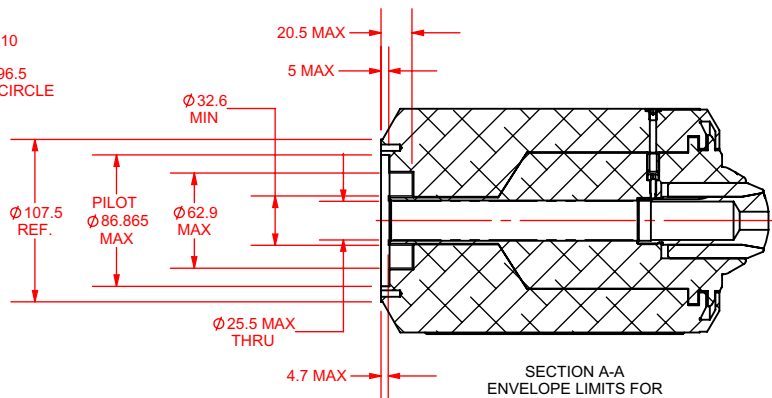

SECTION A-A  
ENVELOPE LIMITS FOR  
WET-CUT ACCESSORY

DIMENSIONS: MILLIMETERS

## CCS Series **Ordering Information**

### CCS130DR Mechanical-Bearing Direct-Drive Rotary Collet Stage

#### Stage Size (Required)

-160 160 mm stage height

#### Cutting Configuration (Required)

-DCUT Dry cutting configuration  
 -WCUT Wet cutting configuration with fluid rotary union

Note: -WCUT option requires a wet-cut seal with O-ring matched to a specific tube diameter (see Ring Seals)

#### Integration (Required)

Aerotech offers both standard and custom integration services to help you get your system fully operational as quickly as possible. The following standard integration options are available for this system. Please consult Aerotech if you are unsure what level of integration is required, or if you desire custom integration support with your system.

-TAS Integration - Test as system  
 Testing, integration, and documentation of a group of components as a complete system that will be used together (ex: drive, controller, and stage). This includes parameter file generation, system tuning, and documentation of the system configuration.

-TAC Integration - Test as components  
 Testing and integration of individual items as discrete components. This is typically used for spare parts, replacement parts, or items that will not be used or shipped together (ex: stage only). These components may or may not be part of a larger system.

### CCS190DR Mechanical-Bearing Direct-Drive Rotary Collet Stage

#### Stage Size and Collet Chuck (Required)

-240-3C 240 mm stage height with 3c collet  
 -260-5C 260 mm stage height with 5c collet

#### Wrench (Optional)

-WR Wrench for changing collet

#### Integration (Required)

Aerotech offers both standard and custom integration services to help you get your system fully operational as quickly as possible. The following standard integration options are available for this system. Please consult Aerotech if you are unsure what level of integration is required, or if you desire custom integration support with your system.

-TAS Integration - Test as system  
 Testing, integration, and documentation of a group of components as a complete system that will be used together (ex: drive, controller, and stage). This includes parameter file generation, system tuning, and documentation of the system configuration.

-TAC Integration - Test as components  
 Testing and integration of individual items as discrete components. This is typically used for spare parts, replacement parts, or items that will not be used or shipped together (ex: stage only). These components may or may not be part of a larger system.

#### Accessories (to be ordered as separate line item)

Collet-3C-CLTxxx Collet, 3C; consult Aerotech for available sizes  
 Collet-5C-CLTxxx Collet, 5C; consult Aerotech for available sizes  
 CGF [Collet and Gripper Filtration Kit](#)