



INTEGRATED GRANITE MOTION SYSTEMS

WHAT IS IGM?

- Integrated Granite Motion (IGM) refers to a type of motion platform, in which the core linear-motion components, including bearings, encoders, and drive mechanisms, are designed and assembled directly onto a granite structure.
- IGM systems can be engineered with mechanical or air bearings, linear-motor or ball-screw drives, and a diverse range of feedback devices from optical position encoders to laser interferometers.

Motion components, such as bearing rails, motors, and feedback devices, are mounted directly to the main granite structure.



IGM OR STAGE COMPONENT SOLUTION?

Aerotech offers extensive experience designing and manufacturing both IGM and stage-on-granite motion platform solutions. As a high-performance motion supplier, we can help you understand the similarities and differences between these two solution types, and help you select the most ideal solution to fit your application requirements.

IGM ADVANTAGES

- Lower axis heights reduce Abbe offsets
- Greater design flexibility
- Higher stiffness due to lower part count



STAGE-ON-GRANITE ADVANTAGES

- Faster design cycle
- Component stages offer drop-in compatibility for easier maintenance and service
- Easier protection from contamination and debris

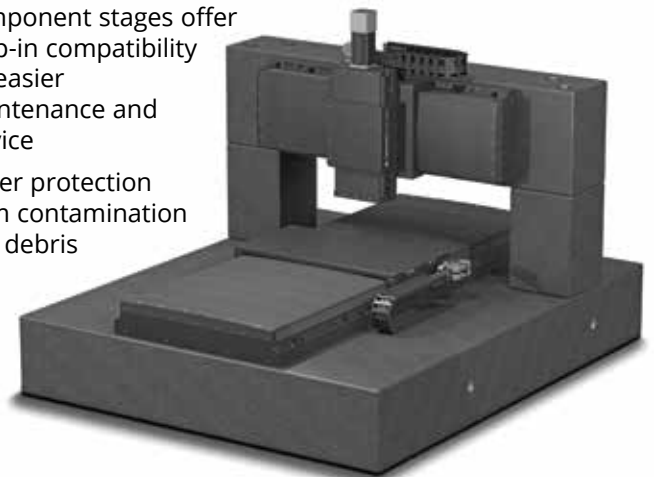

ANATOMY OF AN IGM SOLUTION

IGM solutions offer distinct benefits in terms of design flexibility and motion performance. From the selection of drive and bearing types to system layout and arrangement, IGM systems are custom-tailored to achieve your motion requirements, with offerings spanning from single-axis solutions to fully-integrated motion platforms. Several IGM features and options are illustrated below.

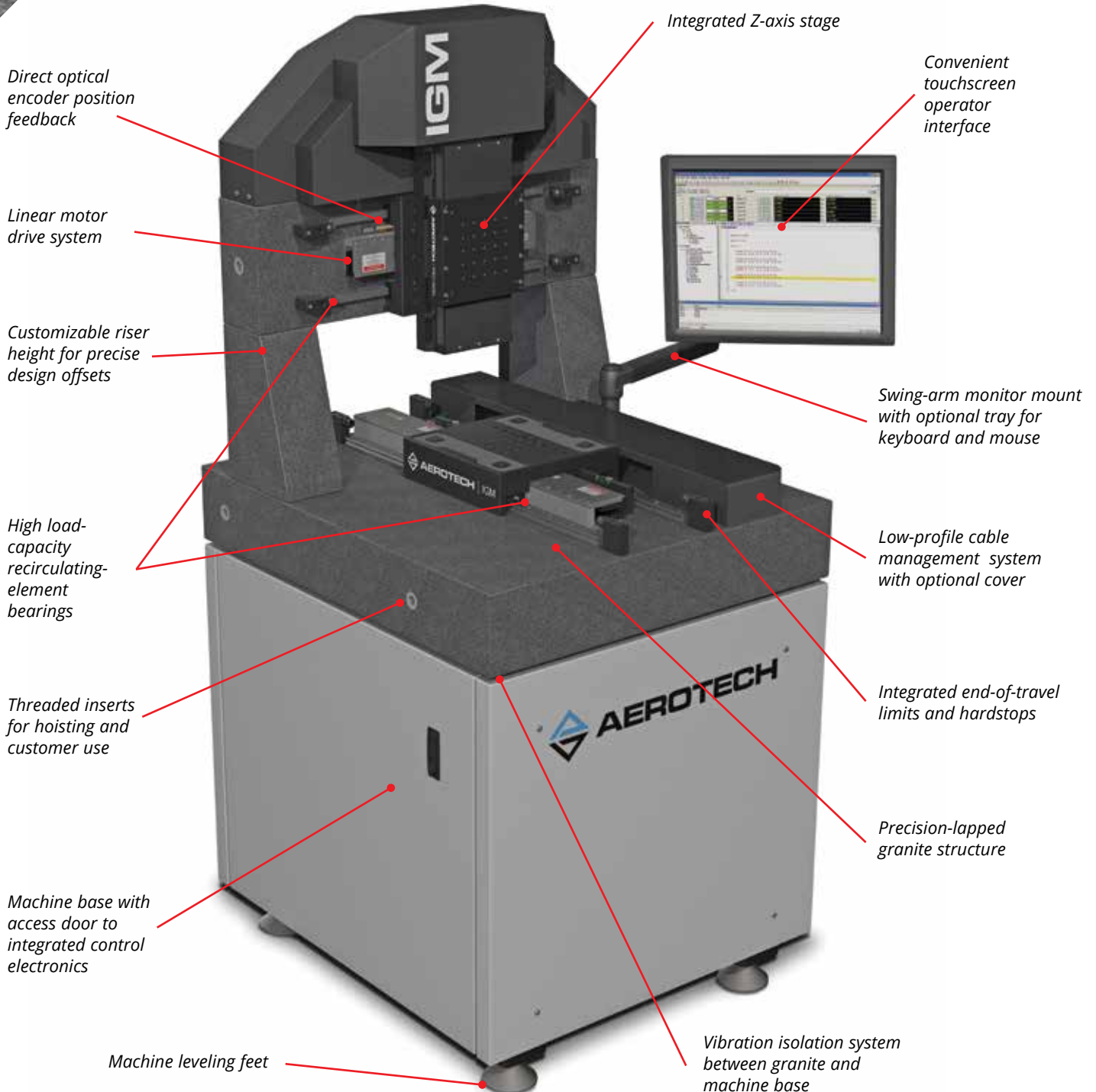

IGM PLATFORM EXAMPLES

Aerotech IGM systems are specially designed around application-specific performance and commercial requirements. While each design is fundamentally unique, several more common IGM variants are represented below.

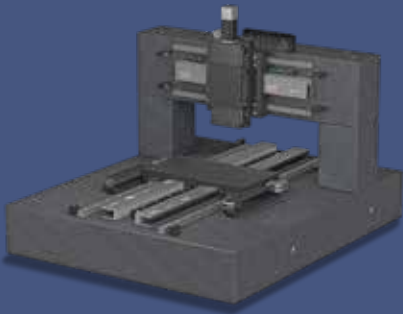

MECHANICAL-BEARING

- Recirculating-element bearings offer robust motion performance
- Linear-motor or ball-screw drive options available

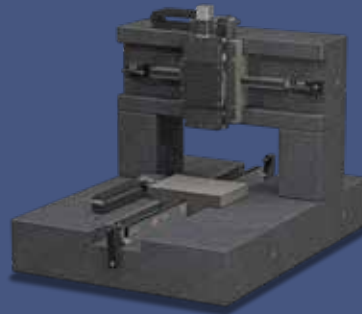

AIR-BEARING

- Granite air-bearing surfaces offer ultra-precise, repeatable motion
- Direct-drive linear motors support smooth motion profiles



HYBRID-BEARING

- Combination of air- and mechanical-bearing axes to balance performance and cost
- Air-bearing axis optimized for high-accuracy scanning



SINGLE-AXIS SOLUTIONS

- Versatile design can be integrated as part of a larger machine, or can exist as a stand-alone axis
- Air-bearing and mechanical-bearing variants available as single-axis



UNIVERSAL MACHINE PLATFORM

- IGM platform plus machine base with integrated control electronics
- Isolation system minimizes the effects of external vibrations and disturbances



VERTICAL SCREW-DRIVE

- Dual vertical ball-screw drive system for precise positioning of heavy payloads
- Direct linear encoders for enhanced position feedback



Dedicated to the Science of Motion

Since 1970, Aerotech has designed and manufactured the highest performance motion control, positioning tables/stages, and positioning systems for our customers in industry, government, science, and research institutions around the world.