

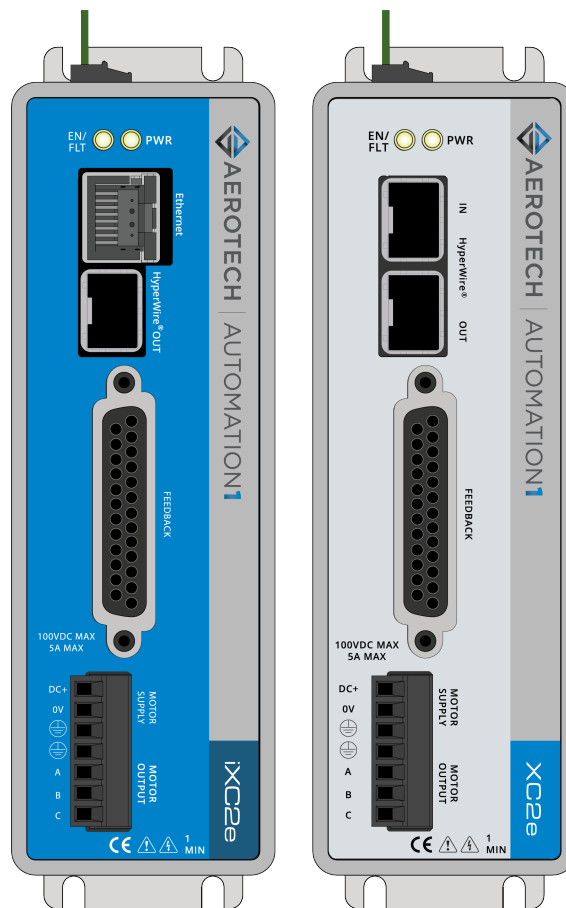

Automation1 iXC2e and XC2e High-Performance PWM Digital Drives

HARDWARE MANUAL

Revision 2.05



GLOBAL TECHNICAL SUPPORT

Go to the [Global Technical Support Portal](#) for information and support about your Aerotech, Inc. products. The website supplies software, product manuals, Help files, training schedules, and PC-to-PC remote technical support. If necessary, you can complete Product Return (RMA) forms and get information about repairs and spare or replacement parts. To get help immediately, contact a service office or your sales representative. Include your customer order number in your email or have it available before you call.

This manual contains proprietary information and may not be reproduced, disclosed, or used in whole or in part without the express written permission of Aerotech, Inc. Product names mentioned herein are used for identification purposes only and may be trademarks of their respective companies.

Copyright © 2019-2022, Aerotech, Inc., All rights reserved.



Table of Contents

Automation1 iXC2e and XC2e High-Performance PWM Digital Drives	1
Table of Contents	3
List of Figures	5
List of Tables	7
EU Declaration of Conformity	9
Agency Approvals	10
Safety Procedures and Warnings	11
Handling and Storage	13
Installation Overview	14
Chapter 1: iXC2e/XC2e Overview	17
1.1. Electrical Specifications	21
1.1.1. System Power Requirements	21
1.2. Mechanical Specifications	22
1.2.1. Mounting and Cooling	22
1.2.2. Dimensions	23
1.3. Environmental Specifications	25
1.4. Drive and Software Compatibility	25
Chapter 2: Installation and Configuration	27
2.1. Input Power Connections	27
2.1.1. Control Supply Connector	27
2.1.2. Motor Supply Connector	28
2.1.3. Minimizing Noise for EMC/CE Compliance	29
2.2. Motor Power Output Connector	30
2.2.1. Brushless Motor Connections	31
2.2.1.1. Brushless Motor Powered Motor and Feedback Phasing	32
2.2.1.2. Brushless Motor Unpowered Motor and Feedback Phasing	33
2.2.2. DC Brush Motor Connections	34
2.2.2.1. DC Brush Motor Phasing	34
2.2.3. Stepper Motor Connections	35
2.2.3.1. Stepper Motor Phasing	35
2.2.4. Three Phase Stepper Motor Connections	36
2.2.4.1. Stepper Motor Phasing	36
2.3. Feedback Connector	37
2.3.1. Primary Encoder Inputs	38
2.3.1.1. Square Wave Encoder (Primary)	39
2.3.1.2. Absolute Encoder (Primary)	40
2.3.1.3. Sine Wave Encoder (Primary) [-MX2/-MX3 Option]	41
2.3.1.4. Encoder Phasing	43
2.3.2. Hall-Effect Inputs	44
2.3.3. Thermistor Input	45
2.3.4. Encoder Fault Input	46
2.3.5. End of Travel and Home Limit Inputs	47
2.3.5.1. End of Travel and Home Limit Phasing	49
2.3.6. Brake Outputs	50
2.4. Safe Torque Off Input (STO)	51
2.4.1. STO Standards	53
2.4.2. STO Functional Description	54
2.4.3. STO Startup Validation Testing	55
2.4.4. STO Diagnostics	56
2.5. HyperWire Interface	57
2.6. System Interconnection	58
2.7. PC Configuration and Operation Information	61
Chapter 3: -EB1/-EB2 Option Expansion Board	63
3.1. PSO Interface [-EB1/-EB2]	64
3.2. Auxiliary Encoder Interface [-EB1/-EB2]	66
3.2.1. Square Wave Encoder (Auxiliary)	67

3.2.2. Absolute Encoder (Auxiliary)	68
3.2.3. Sine Wave Encoder (Auxiliary) [-MX3 Option]	69
3.3. Analog I/O [-EB1]	71
3.3.1. Analog Output 0 [-EB1]	71
3.3.2. Analog Input (Differential) [-EB1]	72
3.4. Digital Outputs [-EB1]	73
3.5. Digital Inputs [-EB1]	76
3.6. Industrial Ethernet (iXC2e -EB2 Option Only)	79
Chapter 4: Cables and Accessories	81
4.1. DIN Rail Mounting	82
4.2. Joystick Interface	83
4.3. Handwheel Interface	84
4.4. Dual-PSO Adapter Cable	85
Chapter 5: Maintenance	87
5.1. Preventative Maintenance	88
5.2. Fuse Specifications	88
Appendix A: Warranty and Field Service	89
Appendix B: Revision History	91
Index	93

List of Figures

Figure 1-1:	iXC2e High Performance PWM Amplifier	17
Figure 1-2:	XC2e High Performance PWM Amplifier	18
Figure 1-3:	Functional Diagram	20
Figure 1-4:	Dimensions [-EB0]	23
Figure 1-5:	Dimensions [-EB1/-EB2]	24
Figure 2-1:	Control Supply Connections	27
Figure 2-2:	Motor Supply Connections	28
Figure 2-3:	Brushless Motor Configuration	31
Figure 2-4:	Positive Motor Direction	32
Figure 2-5:	Encoder and Hall Signal Diagnostics	32
Figure 2-6:	Brushless Motor Phasing Oscilloscope Example	33
Figure 2-7:	Brushless Motor Phasing Goal	33
Figure 2-8:	DC Brush Motor Configuration	34
Figure 2-9:	Positive Motor Direction	34
Figure 2-10:	Stepper Motor Configuration	35
Figure 2-11:	Positive Motor Direction	35
Figure 2-12:	Stepper Motor Configuration	36
Figure 2-13:	Positive Motor Direction	36
Figure 2-14:	Square Wave Encoder Schematic (Feedback Connector)	39
Figure 2-15:	Absolute Encoder Schematic (Feedback Connector)	40
Figure 2-16:	Sine Wave Encoder Phasing Reference Diagram	41
Figure 2-17:	Sine Wave Encoder Schematic (Feedback Connector)	42
Figure 2-18:	Encoder Phasing Reference Diagram (Standard)	43
Figure 2-19:	Position Feedback in the Diagnostic Display	43
Figure 2-20:	Hall-Effect Inputs Schematic (Feedback Connector)	44
Figure 2-21:	Thermistor Input Schematic (Feedback Connector)	45
Figure 2-22:	Encoder Fault Input Schematic (Feedback Connector)	46
Figure 2-23:	End of Travel and Home Limit Input Connections	48
Figure 2-24:	End of Travel and Home Limit Input Schematic (Feedback Connector)	48
Figure 2-25:	End of Travel and Home Limit Input Diagnostic Display	49
Figure 2-26:	Brake Connected to the 25-Pin Feedback Connector (Typical)	50
Figure 2-27:	Typical STO Configuration	52
Figure 2-28:	STO Timing	56
Figure 2-29:	Drive-Based System Wiring Drawing (Best Practice)	58
Figure 2-30:	PC-Based System Wiring Drawing (Best Practice)	58
Figure 2-31:	Drive-Based Controller System Interconnection (Best Practice)	59
Figure 2-32:	PC-Based Controller System Interconnection (Best Practice)	60
Figure 3-1:	Expansion Option Board Connectors (iXC2e shown)	63
Figure 3-2:	PSO Output Sources Current	65
Figure 3-3:	PSO Output Sinks Current	65
Figure 3-4:	PSO TTL Outputs Schematic	65
Figure 3-5:	Square Wave Encoder Interface (Aux Connector)	67
Figure 3-6:	Absolute Encoder Schematic (Auxiliary Encoder Connector)	68
Figure 3-7:	Sine Wave Encoder Phasing Reference Diagram	69
Figure 3-8:	Sine Wave Encoder Schematic (Aux Connector)	70
Figure 3-9:	Analog Output Schematic [-EB1]	71
Figure 3-10:	Analog Input Schematic [-EB1]	72
Figure 3-11:	Digital Outputs Schematic [-EB1]	74

Figure 3-12: Digital Outputs Connected in Current Sourcing Mode [-EB1]	75
Figure 3-13: Digital Outputs Connected in Current Sinking Mode [-EB1]	75
Figure 3-14: Digital Inputs Schematic [-EB1]	77
Figure 3-15: Digital Inputs Connected to Current Sourcing (PNP) Devices [-EB1]	78
Figure 3-16: Digital Inputs Connected to Current Sinking (NPN) Devices [-EB1]	78
Figure 4-1: Din Rail Clip Dimensions	82
Figure 4-2: Two Axis Joystick Interface	83
Figure 4-3: Handwheel Interconnection to the Aux Connector	84
Figure 4-4: Dual-Axis PSO Cable Connection	85

List of Tables

Table 1-1:	Feature Summary	19
Table 1-2:	Electrical Specifications	21
Table 1-3:	Mounting Specifications	22
Table 1-4:	Environmental Specifications	25
Table 1-5:	Drive and Software Compatibility	25
Table 2-1:	Control Supply Connector Pinout	27
Table 2-2:	Control Supply Mating Connector Ratings	27
Table 2-3:	Motor Supply Connector Pinout	28
Table 2-4:	Motor Supply Mating Connector Ratings	28
Table 2-5:	Motor Power Output Connector Pinout	30
Table 2-6:	Motor Power Output Mating Connector Ratings	30
Table 2-7:	Wire Colors for Aerotech-Supplied Brushless Motor Cables	31
Table 2-8:	Hall Signal Diagnostics	32
Table 2-9:	Wire Colors for Aerotech-Supplied DC Brush Motor Cables	34
Table 2-10:	Wire Colors for Aerotech-Supplied Stepper Motor Cables	35
Table 2-11:	Feedback Connector Pinout	37
Table 2-12:	Feedback Mating Connector Ratings	37
Table 2-13:	Multiplier Options	38
Table 2-14:	Primary Encoder Pins on the Feedback Connector	38
Table 2-15:	Square Wave Encoder Specifications	39
Table 2-16:	Sine Wave Encoder Specifications	41
Table 2-17:	Hall-Effect Feedback Pins on the Feedback Connector	44
Table 2-18:	Thermistor Input Pin on the Feedback Connector	45
Table 2-19:	Encoder Fault Input Pin on the Feedback Connector	46
Table 2-20:	End of Travel and Home Limit Pins on the Feedback Connector	47
Table 2-21:	Brake Output Pins on the Feedback Connector	50
Table 2-22:	Brake Control Specifications	50
Table 2-23:	STO Connector Pinout	51
Table 2-24:	STO Mating Connector Ratings	51
Table 2-25:	STO Electrical Specifications	52
Table 2-26:	STO Standards	53
Table 2-27:	STO Standards Data	53
Table 2-28:	STO Signal Delay	55
Table 2-29:	Motor Function Relative to STO Input State	55
Table 2-30:	STO Timing	56
Table 2-31:	HyperWire Card Part Number	57
Table 2-32:	HyperWire Cable Part Numbers	57
Table 3-1:	PSO Specifications [-EB1/-EB2]	64
Table 3-2:	PSO Interface Connector Pinout [-EB1/-EB2]	64
Table 3-3:	PSO Interface Mating Connector Ratings [-EB1/-EB2]	64
Table 3-4:	Auxiliary Encoder Connector Pinout	66
Table 3-5:	AUX Mating Connector Ratings	66
Table 3-6:	Square Wave Encoder Specifications	67
Table 3-7:	Sine Wave Encoder Specifications	69
Table 3-8:	Analog I/O Connector Pinout [-EB1]	71
Table 3-9:	Analog I/O Mating Connector Ratings [-EB1]	71
Table 3-10:	Analog Output Specifications [-EB1]	71
Table 3-11:	Analog Output Pins on the Analog I/O Connector [-EB1]	71

Table 3-12: Differential Analog Input Specifications [-EB1]	72
Table 3-13: Analog Input Pins on the Analog I/O Connector [-EB1]	72
Table 3-14: Digital Output Specifications [-EB1]	73
Table 3-15: Digital Output Connector Pinout [-EB1]	73
Table 3-16: Digital Output Mating Connector Ratings [-EB1]	73
Table 3-17: Digital Input Specifications [-EB1]	76
Table 3-18: Digital Input Connector Pinout [-EB1]	76
Table 3-19: Digital Input Mating Connector Ratings [-EB1]	76
Table 4-1: Standard Interconnection Cables	81
Table 4-2: Mounting Parts	82
Table 5-1: LED Description	87
Table 5-2: Troubleshooting	87
Table 5-3: Preventative Maintenance	88
Table 5-4: Control Board Fuse Specifications	88

EU Declaration of Conformity

Manufacturer Aerotech, Inc.
Address 101 Zeta Drive
 Pittsburgh, PA 15238-2811
 USA
Product iXC2e/XC2e
Model/Types All

This is to certify that the aforementioned product is in accordance with the applicable requirements of the following directive(s):

2014/30/EU	Electromagnetic Compatibility (EMC)
2014/35/EU	Low Voltage Directive
2006/42/EC	Machinery Directive
2011/65/EU	RoHS 2 Directive
EU 2015/863	Amendment RoHS 3 Directive

and has been designed to be in conformity with the applicable requirements of the following standard(s) when installed and used in accordance with the manufacturer's supplied installation instructions.

EN 61010-1:2010/AMD1:2016	Safety Requirements for Electrical Equipment
EN 61800-3:2004/A1:2011	EMC Requirements for Power Drives
IEC 61800-5-1:2016	Electrical Safety for Power Drive Systems
IEC 61800-5-2:2016	Functional Safety for Power Drive Systems
EN 55011:2000/A2:2003	Conducted and Radiated Emissions
EN 55022:1998	Conducted and Radiated Emissions

Authorized Representative



/ Simon Smith, European Director

Aerotech Ltd
 The Old Brick Kiln, Ramsdell, Tadley
 Hampshire RG26 5PR
 UK

Engineer Verifying Compliance



/ Alex Weibel

Aerotech, Inc.
 101 Zeta Drive
 Pittsburgh, PA 15238-2811
 USA
 7/19/2022

Date



Agency Approvals

Aerotech tested its XC2e drives and found that they obey the standards that follow:

Approval: CUS NRTL
Approving Agency: TÜV SÜD America Inc.
Certificate #: U10 068995 0033 Rev. 00
Standards: CSA C22.2 No. 61010-1:2012/A1:2018-11,
 UL 61010-1:2012/R2019-07



Certificate #: N8AUS 068995 0032 Rev. 01
Standards: CE Attestation of Conformity,
 Low Voltage Directive 2014/35/EU,
 EN 61010-1:2010/AMD1:2019



IMPORTANT: The safety components (STO) certification is pending for the iXC2e.

Approval: Safety Components (STO)
Approving Agency: TÜV SÜD
Certificate #: Z10 068995 0030 Rev. 00
Standards: EN ISO 13849-1:2015 (up to PL e),
 IEC 61508-1:2010 (up to SIL3),
 IEC 61508-2:2010 (up to SIL3),
 IEC 61800-5-2:2016,
 IEC 62061:2005 (up to SILCL3),
 IEC 62061:2005/AMD1:2012 (up to SILCL3),
 IEC 62061:2005/AMD2:2015 (up to SILCL3)



Visit <https://www.tuev-sued.de/product-testing/certificates> to view Aerotech's TÜV SÜD certificates. Type the certificate number listed above in the search bar or type "Aerotech" for a list of all Aerotech certificates.

Safety Procedures and Warnings

IMPORTANT: This manual tells you how to carefully and correctly use and operate the drive.



- Read all parts of this manual before you install or operate the drive or before you do maintenance to your system.
- To prevent injury to you and damage to the equipment, obey the precautions in this manual.
- All specifications and illustrations are for reference only and were complete and accurate as of the release of this manual. To find the newest information about this product, refer to www.aerotech.com.

If you do not understand the information in this manual, contact Aerotech Global Technical Support.

IMPORTANT: This product has been designed for light industrial manufacturing or laboratory environments. If the product is used in a manner not specified by the manufacturer:



- The protection provided by the equipment could be impaired.
- The life expectancy of the product could be decreased.

Safety notes and symbols are placed throughout this manual to warn you of the potential risks at the moment of the safety note or if you fail to obey the safety note.



The voltage can cause shock, burn, or death.



You are at risk of physical injury.
You could damage the drive.



A surface can be hot enough to burn you.



Your actions, the temperature of the system, or the condition of the atmosphere that surround the system could start a fire.



Components are sensitive to electrostatic discharge.



Unsecured cables could cause you to:

- trip and fall
- drag the product off of its mounting location
- damage the cable connections.



A blue circle symbol is an action or tip that you should obey. Some examples include:



- General tip
- Read the manual/section
- Wear protective safety equipment (eye protection, ear protection, gloves)
- If applicable, do not lift unassisted

DANGER: To decrease the risk of electrical shock, injury, death, and damage to the equipment, obey the precautions that follow.



1. Before you do maintenance to the equipment, disconnect the electrical power.
2. Restrict access to the drive when it is connected to a power source.
3. Do not connect or disconnect electrical components, wires, and cables while this product is connected to a power source.
4. Wait at least one (1) minute after removing the power supply before doing maintenance or an inspection. Otherwise, there is the danger of electric shock.
5. Supply each operator with the necessary protection from live electrical circuits.
6. Make sure that all components are grounded correctly and that they obey the local electrical safety requirements.
7. Install the necessary precautions to supply safety and protection to the operator.



DANGER: System travel can cause crush, shear, or pinch injuries. Restrict access to all motor and stage parts while your system is connected to a power source.



WARNING: To prevent damage to the equipment and decrease the risk of electrical shock and injury, obey the precautions that follow.

1. Make sure that all system cables are correctly attached and positioned.
2. Do not use the cables or the connectors to lift or move this product.
3. Use this product only in environments and operating conditions that are approved in this manual.
4. Only trained operators should operate this equipment.

Handling and Storage

Unpacking the drive



IMPORTANT: All electronic equipment and instrumentation is wrapped in antistatic material and packaged with desiccant. Ensure that the antistatic material is not damaged during unpacking.

Inspect the shipping container for any evidence of shipping damage. If any damage exists, notify the shipping carrier immediately.

Remove the packing list from the shipping container. Make sure that all the items specified on the packing list are contained within the package.

The documentation for the drive is on the included installation device. The documents include manuals, interconnection drawings, and other documentation pertaining to the system. Save this information for future reference. Additional information about the system is provided on the Serial and Power labels that are placed on the chassis.

The system serial number label contains important information such as the:

- Customer order number (please provide this number when requesting product support)
- Drawing number
- System part number

Handling



IMPORTANT: It is the responsibility of the customer to safely and carefully lift and move the drive.

- Be careful when you move or transport the drive.
- Refer to [Section 1.2. Mechanical Specifications](#) for dimensions and weight specifications.
- Retain the shipping materials for future use.
- Transport or store the drive in its protective packaging.



WARNING: Electrostatic Discharge (ESD) Sensitive Components!

You could damage the power supply or drives if you fail to observe the correct ESD practices.

Wear an ESD wrist strap when you handle, install, or do service to the system assembly.

Storage

Store the drive in the original shipping container. If the original packaging included ESD protective packaging, make sure to store the drive in it. The storage location must be dry, free of dust, free of vibrations, and flat.

Refer to [Section 1.3. Environmental Specifications](#).

Installation Overview

The images that follow show the order in which to make connections and settings that are typical to the iXC2e/XC2e. If a custom interconnect drawing was supplied with your system, that drawing is on your Storage Device and shows as a line item on your Sales Order in the Integration section.

Figure 1: Installation Connection Overview for the iXC2e

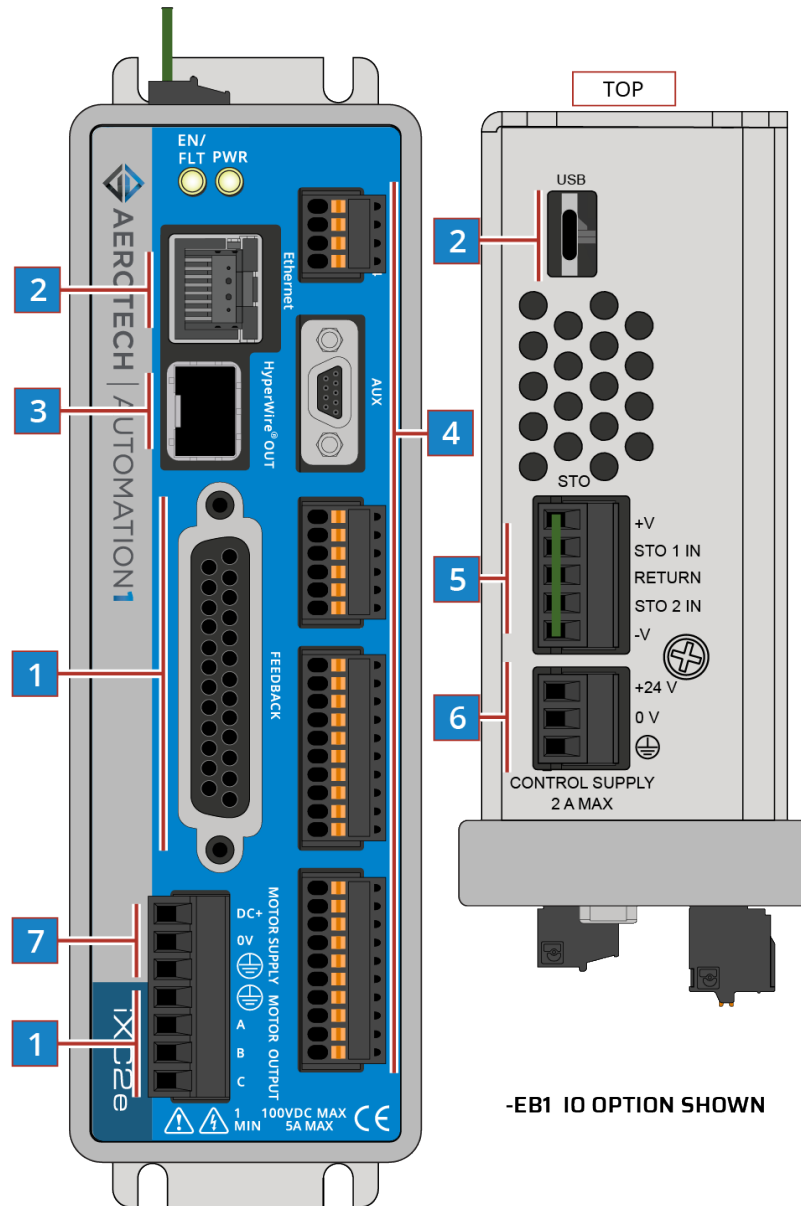

1	Connect the motor to the amplifier Motor Output connector.	Section 2.2.
	Connect the motor to the amplifier Feedback connector.	Section 2.3.
2	Connect the PC to the USB or Ethernet port.	N/A
3	Connect the next drive in the system to the HyperWire Out port.	Section 2.5.
4	Connect additional I/O as required by your application (if you purchased the I/O option).	Chapter 3
5	Connect the Safe Torque Off (STO).	Section 2.4.
6	Connect the power supply to the Control Supply connector.	Section 2.1.1.
7	Connect the motor power to the Motor Supply connector.	Section 2.1.2.

Figure 2: Installation Connection Overview for the XC2e

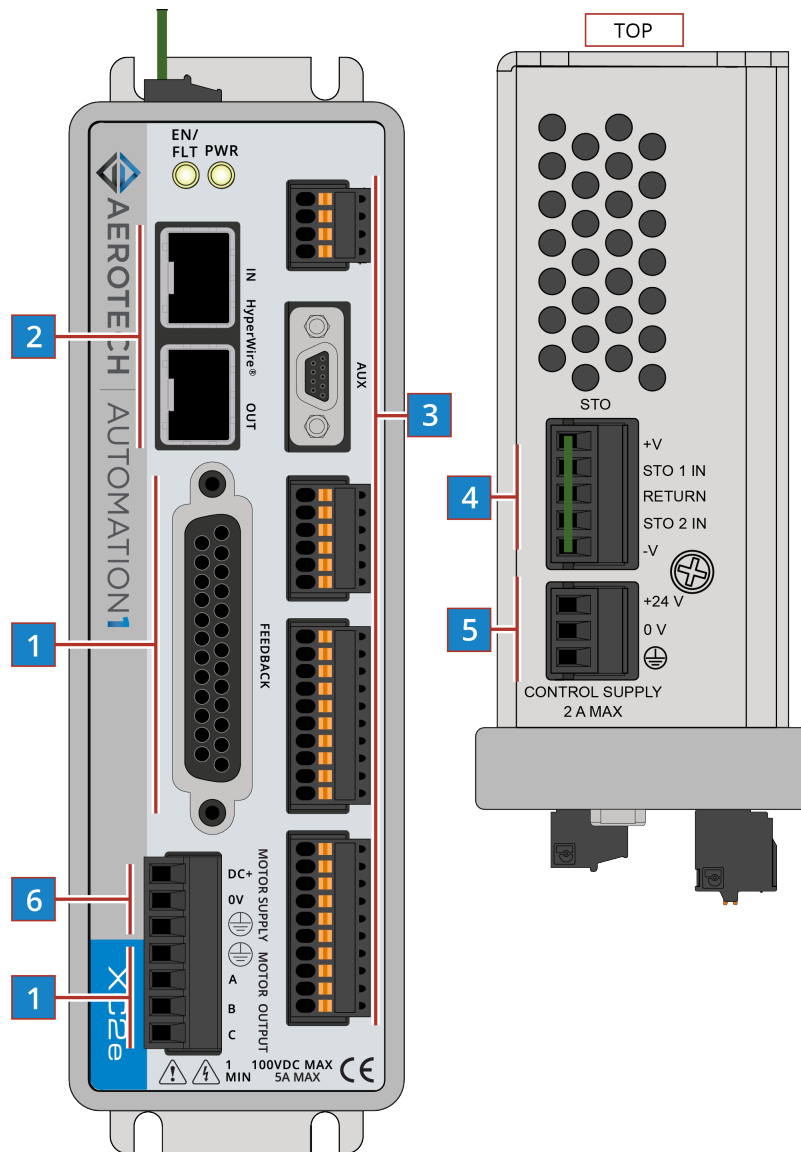

1	Connect the motor to the amplifier Motor Output connector.	Section 2.2.
	Connect the motor to the amplifier Feedback connector.	Section 2.3.
2	Connect a PC or drive-based controller HyperWire port to the HyperWire In port.	Section 2.5.
3	Connect additional I/O as required by your application (if you purchased the I/O option).	Chapter 3
4	Connect the Safe Torque Off (STO).	Section 2.4.
5	Connect the power supply to the Control Supply connector.	Section 2.1.1.
6	Connect the motor power to the Motor Supply connector.	Section 2.1.2.

This page intentionally left blank.

Chapter 1: iXC2e/XC2e Overview

The iXC2e is a high-performance digital drive-based controller. It runs the Automation1-iSMC controller to generate commands for itself as well as for additional drives on the chain.

The XC2e is a high performance digital drive. The XC2e is based on the HyperWire communication protocol and receives commands from a PC or drive-based controller.

Both drives provide deterministic behavior and auto-identification and are fully software configurable. A double precision floating point DSP controls the digital PID and current loops in the drive.

Figure 1-1: iXC2e High Performance PWM Amplifier

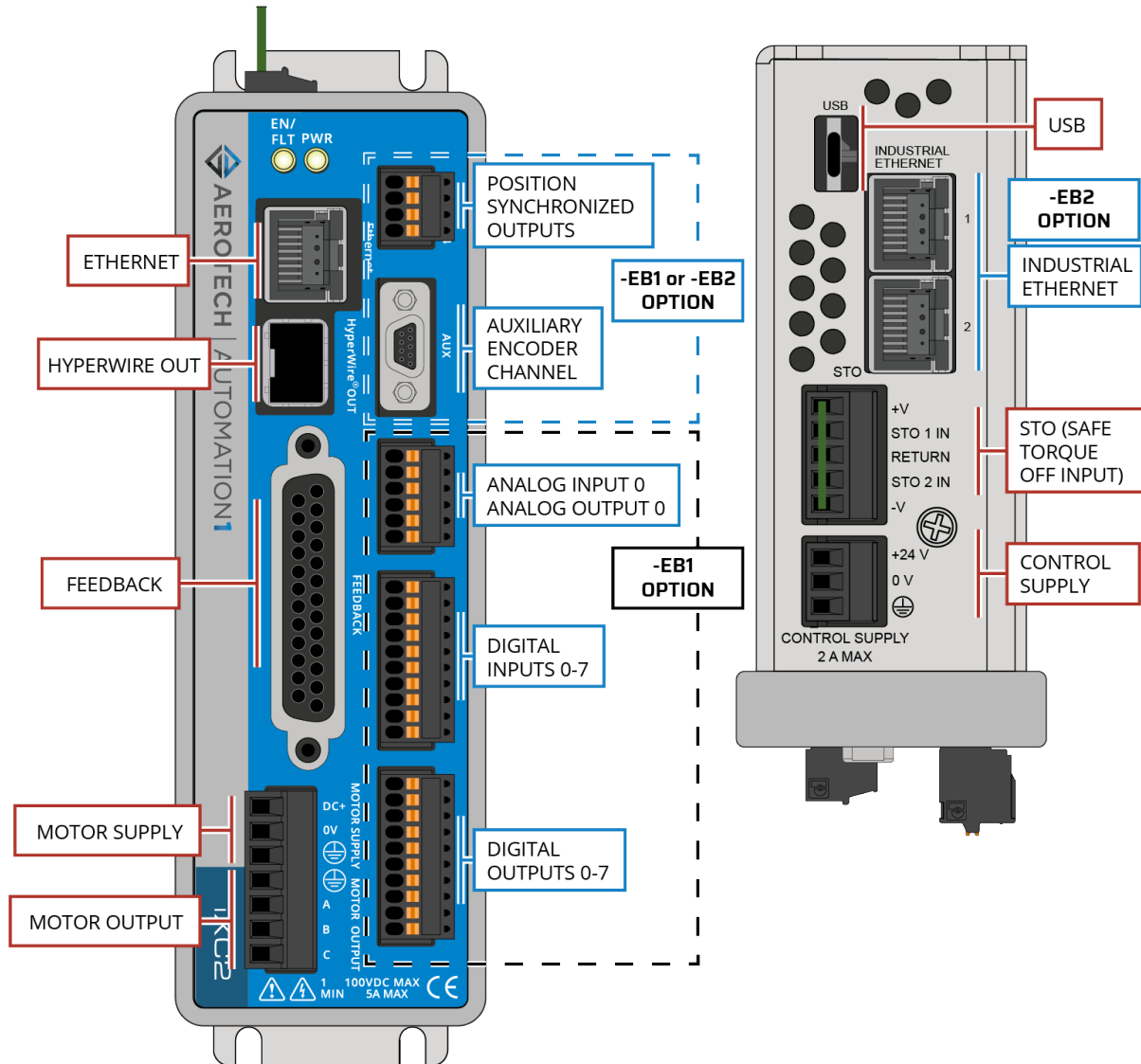

Figure 1-2: XC2e High Performance PWM Amplifier

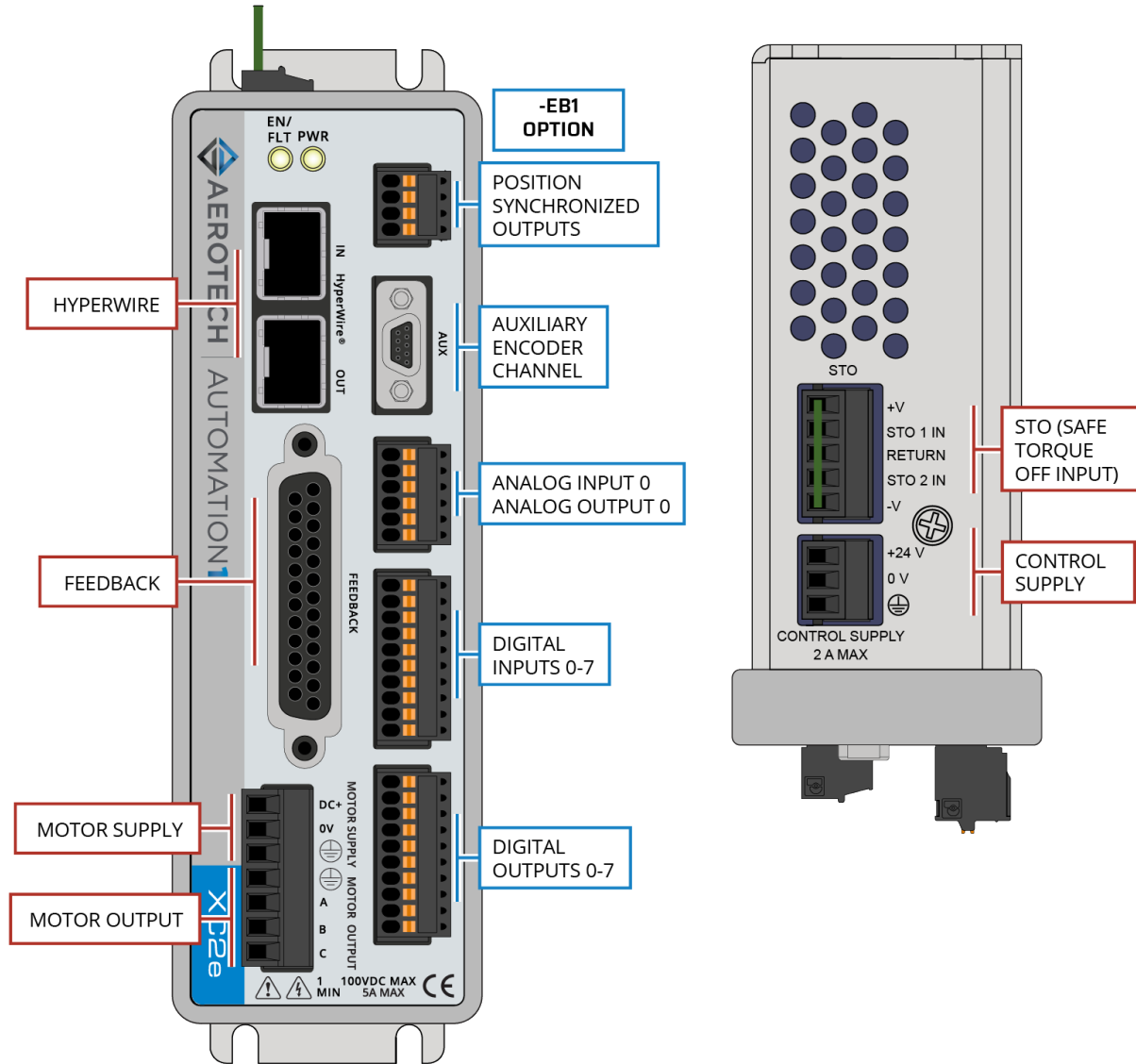
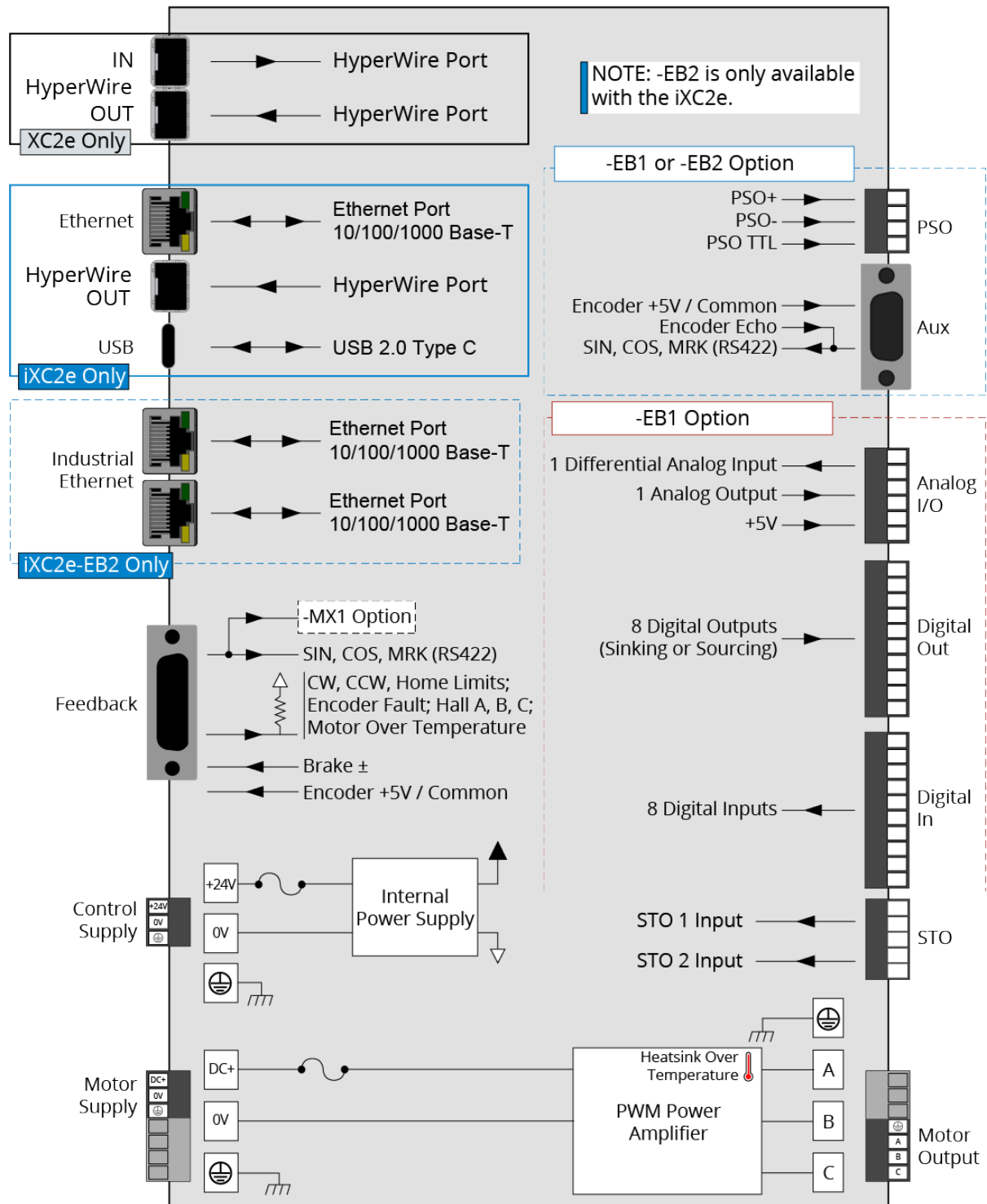

Table 1-1: Feature Summary

Standard Features	
<ul style="list-style-type: none"> • 24 VDC control supply input (Section 2.1.1.) • 15-100 VDC motor supply inputs (Section 2.1.2.) • Line driver square wave quadrature encoder input for position and velocity feedback (Section 2.3.1.) • Absolute Encoder support (Section 2.3.1.2.) • One fail-safe brake output (Section 2.3.6.) • Two STO sense inputs (Section 2.4.) • One 10/100/1000 BASE-T Ethernet Port (iXC2e Only) • One USB 2.0 Type C Port (iXC2e Only) 	
Options	
Peak Current (Section 1.1.)	
-10	10 A Peak, 5 A Continuous Current
Expansion Board (Chapter 3)	
-EB0	No expansion board
-EB1	I/O expansion board <ul style="list-style-type: none"> • Digital logic laser firing (PSO) output • Auxiliary encoder input channel • 16-bit analog output (± 10 V) • 16-bit differential analog input (± 10 V) • 8 digital logic inputs (5 - 24 VDC), can be connected to current sourcing or sinking devices • 8 digital logic outputs (5 - 24 VDC), can be connected as current sourcing or sinking
-EB2	Industrial Ethernet Expansion board (iXC2e only) <ul style="list-style-type: none"> • Digital logic laser firing (PSO) output • Auxiliary encoder input channel • Two 10/100/1000 BASE-T Industrial Ethernet Ports
PSO (Section 3.1.)	
-PSO1	One-axis PSO firing (includes One-axis Part-Speed PSO)
-PSO2	Two-axis PSO firing (includes Three-axis Part-Speed PSO)
-PSO5	Two-axis Part-Speed PSO firing, which uses the PSO firing circuit based off of the commanded vector velocity of up to 2 axes (includes One-Axis PSO).
-PSO6	Three-axis Part-Speed PSO firing, which uses the PSO firing circuit based off of the commanded vector velocity of 3 or more axes (includes One-Axis PSO).
NOTE: Requires -EB1 or -EB2 option to generate a PSO output pulse	
Multiplier (Section 2.3.1.3.)	
-MX0	No encoder multiplier
-MX2	Interpolation circuit allowing for analog sine wave input on the primary encoder channel with an interpolation factor of 65,536.
-MX3	Interpolation circuit allowing for analog sine wave input on the primary encoder channel with an interpolation factor of 65,536 and an auxiliary encoder channel with an interpolation factor of 16,384.
Version	
-DEFAULT	Firmware Matches Software Line
-LEGACY	Legacy Firmware Version X.XX.XXX

The block diagram that follows shows a summary of the connector signals.

Figure 1-3: Functional Diagram



1.1. Electrical Specifications

Table 1-2: Electrical Specifications

Description		iXC2e/XC2e-10
Motor Supply	Input Voltage	15-100 VDC max
	Input Current (Continuous)	5 A _{rms}
	Input Current	Refer to Section 1.1.1. System Power Requirements
Control Supply	Input Voltage	24 VDC
	Input Current	2 A max, 0.4 A typical without brake
Output Voltage ⁽¹⁾		15-100 VDC
Peak Output Current (1 second)		10 A
Continuous Output Current		5 A
Power Amplifier Bandwidth		2500 Hz maximum (software selectable)
Power Amplifier Efficiency		85% - 95% ⁽²⁾
PWM Switching Frequency		20 kHz
Minimum Load Inductance		0.1 mH @ 100 VDC
User Power Supply Output		5 VDC (@ 500 mA)
Modes of Operation		Brushless; Brush; Stepper
Protective Features		Output short circuit; Peak over current; RMS over current; Over temperature; Control power supply under voltage; Power stage bias supply under voltage
<small>(1) DC input voltage and load dependent.</small>		
<small>(2) Dependent on total output power: efficiency increases with increasing output power.</small>		

1.1.1. System Power Requirements

The following equations can be used to determine total system power requirements. The actual power required from the mains supply will be the combination of actual motor power (work), motor resistance losses, and efficiency losses in the power electronics or power transformer.

Use an EfficiencyFactor of approximately 90% in the following equations.

Brushless Motor

$$\begin{aligned}
 \text{Power Output} &= \text{Torque} \cdot \text{Angular Velocity} && ; \text{ Rotary} \\
 &= \text{Force} \cdot \text{Linear Velocity} && ; \text{ Linear} \\
 &= B_{\text{emf}} \cdot I_{\text{rms}} \cdot 3 && ; \text{ Rotary or Linear} \\
 \text{Power Loss} &= 3 \cdot I_{\text{rms}}^2 \cdot R(\text{line-line})/2 \\
 \text{Power Input} &= (\text{Power Output} + \text{Power Loss}) / \text{EfficiencyFactor}
 \end{aligned}$$

DC Brush Motor

$$\begin{aligned}
 \text{Power Output} &= \text{Torque} \cdot \text{Angular Velocity} \\
 \text{Power Loss} &= I_{\text{rms}}^2 \cdot R \\
 \text{Power Input} &= (\text{Power Output} + \text{Power Loss}) / \text{EfficiencyFactor}
 \end{aligned}$$

1.2. Mechanical Specifications

1.2.1. Mounting and Cooling

The drive must be installed in an enclosed control cabinet suitable for installation of power equipment. A minimum enclosure rating of IP54 is required to comply with safety standards. Make sure that there is sufficient clearance surrounding the drive for free airflow and for the routing of cables and connections. Consideration for items such as line reactors, line filters, and motor chokes or inductance should be made during the initial cabinet design phase.



IMPORTANT: The amount of airflow required to keep the drive temperature within a sufficient range is dependent on the operating conditions. You could be required to supply additional airflow to the drive.

Table 1-3: Mounting Specifications

		iXC2e/XC2e
Customer-Supplied Enclosure		IP54 Compliant
		For DIN Rail Mounting, refer to Section 4.1. DIN Rail Mounting
Weight		0.55 kg
Mounting Hardware		M3.5 [#6] screws (four locations, not included)
Mounting Orientation		Vertical (typical)
Dimensions		Refer to Section 1.2.2. Dimensions
Minimum Clearance	Airflow	~25 mm
	Connectors	~100 mm
Operating Temperature		Refer to Section 1.3. Environmental Specifications
Drive IP Rating		IP20

1.2.2. Dimensions



IMPORTANT: iXC2e and XC2e dimensions are the same. iXC2e is shown.

Figure 1-4: Dimensions [-EB0]

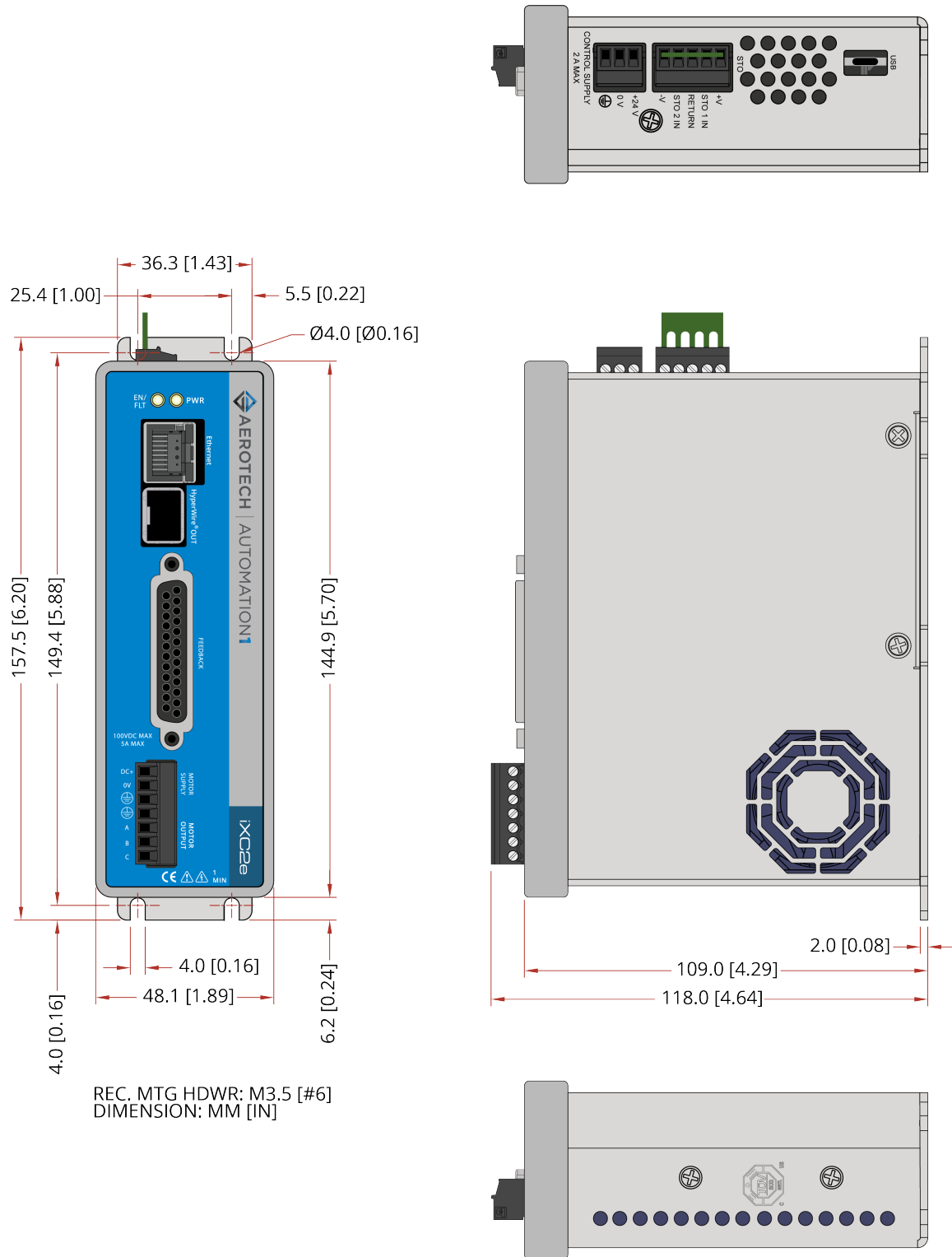



IMPORTANT: iXC2e-EB1/-EB2 and XC2e-EB1 dimensions are the same. iXC2e-EB1 is shown.

Figure 1-5: Dimensions [-EB1/-EB2]

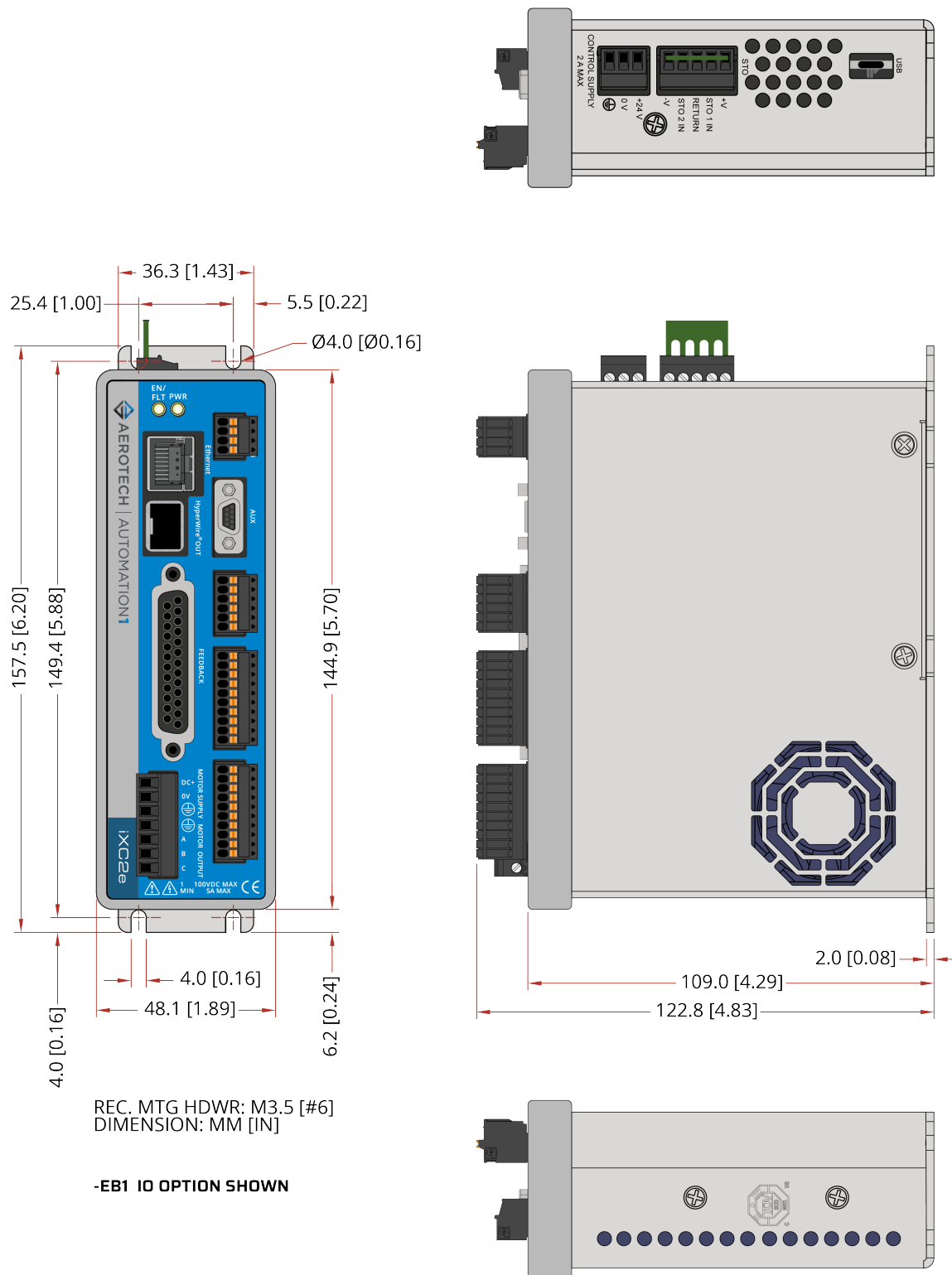

1.3. Environmental Specifications

The environmental specifications are listed below.

Table 1-4: Environmental Specifications

Ambient Temperature	Operating: 0° to 40°C (32° to 104° F)
	Storage: -30° to 85°C (-22° to 185° F)
Humidity Non-condensing	The maximum relative humidity is 80% for temperatures that are less than 31°C and decreases linearly to 50% relative humidity at 40°C.
Operating Altitude	0 m to 2,000 m (0 ft to 6,562 ft) above sea level. If you must operate this product above 2,000 m or below sea level, contact Aerotech, Inc.
Pollution	Pollution Degree 2 Typically only nonconductive pollution occurs.
Operation	Use only indoors

1.4. Drive and Software Compatibility

This table shows the available drives and which version of the software first supported each drive. In the **Last Software Version** column, drives that show a specific version number are not supported after that version.

Table 1-5: Drive and Software Compatibility

Drive Type	First Software Version	Last Software Version
iXC2e	2.2.0	Current
XC2e	2.0.0	Current

This page intentionally left blank.

Chapter 2: Installation and Configuration

The sections in this chapter include details on how to set up the electrical and safety components of your system. Obey all safety warnings, including those in [Safety Procedures and Warnings](#).

2.1. Input Power Connections

The drive has two DC input power connectors. One connector is for control power and the other connector is for motor power. For a full list of electrical specifications, refer to [Section 1.1](#). Refer to [Section 2.6](#) for a System Interconnection Drawing.

2.1.1. Control Supply Connector



DANGER: Shock and Fire Hazard

Electrical wiring must be designed and installed in accordance with local electrical safety regulations to prevent the risk of fire and electrical shock.

The Control Supply input supplies power to the communications and logic circuitry of the drive. The **+24V** input is connected to an internal fuse. Refer to [Table 5-4](#) for the internal fuse value and part number. For an isolated DC supply, connect **0V** to protective ground at the supply. Use twisted pair wiring to minimize radiated noise emissions (refer to [Figure 2-1](#)).

Figure 2-1: Control Supply Connections

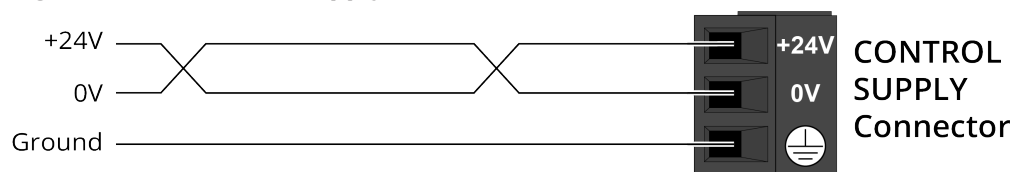

Table 2-1: Control Supply Connector Pinout

Pin	Description
+24 V	24 VDC ($\pm 10\%$) Control Power Input (2 A max, 0.4 A typical without brake)
0 V	Control Power Common Input
	Protective Ground

Table 2-2: Control Supply Mating Connector Ratings

Specification		Description
Type		3-Pin Terminal Block
Part Numbers		Aerotech: ECK02456 Phoenix: 1839610
Conductor Cross Section	One conductor, stranded with ferrule and plastic sleeve	18...22 AWG (0.25...0.75 mm ²)
	Two conductors (same cross-section), stranded, twin ferrule with plastic sleeve	20 AWG (0.5 mm ²)
Tightening Torque		0.22...0.25 N·m
Conductor Insulation Strip Length		7 mm (0.25 in)
(1) Refer to the manufacturer website for additional information.		

2.1.2. Motor Supply Connector



DANGER: Shock and Fire Hazard

Electrical wiring must be designed and installed in accordance with local electrical safety regulations to prevent the risk of fire and electrical shock.

Motor power is applied to the **DC+** and **0V** terminals of the Motor Supply connector. The **DC+** input is connected to an internal fuse. Refer to [Table 5-4](#) for the internal fuse value and part number. For an isolated DC supply, connect **0V** to protective ground at the supply. Use twisted pair wiring to minimize radiated noise emissions (refer to [Figure 2-2](#)).

Figure 2-2: Motor Supply Connections

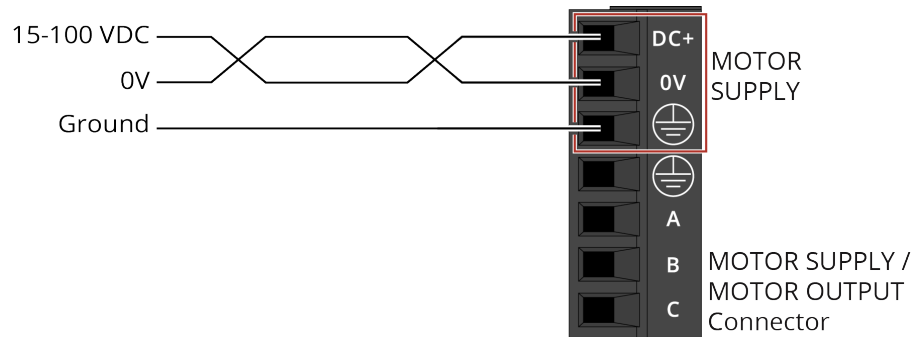

Table 2-3: Motor Supply Connector Pinout

Pin	Description
DC+	Motor Power Input (15-100 VDC)
0 V	Motor Power Input Common
	Protective Ground - 0.75 mm ² / 18 AWG min conductor size

Table 2-4: Motor Supply Mating Connector Ratings

Specification		Description
Type		7-Pin Terminal Block
Part Numbers		Aerotech: ECK02457 Phoenix: 1839678
Conductor Cross Section	One conductor, stranded with ferrule and plastic sleeve	18...22 AWG (0.25...0.75 mm ²)
	Two conductors (same cross-section), stranded, twin ferrule with plastic sleeve	20 AWG (0.5 mm ²)
Tightening Torque		0.22...0.25 N·m
Conductor Insulation Strip Length		7 mm (0.25 in)
(1) Refer to the manufacturer website for additional information.		

2.1.3. Minimizing Noise for EMC/CE Compliance



IMPORTANT: The iXC2e/XC2e is a component designed to be integrated with other electronics. EMC testing must be conducted on the final product configuration.

To reduce electrical noise, observe the following motor feedback and input power wiring techniques.

1. Use shielded cable for motor and feedback connectors. Connect the shield to the backshell at each end of the cable.
2. Separate motor and power wiring from encoder and I/O wiring.
3. Mount drives, power supplies, and filter components on a conductive panel. Keep wire-run lengths to a minimum. For the AC power lines feeding the VDC Motor supply and VDC Control supply, place a line filter, such as Schaffner FN2070-10-06 (Aerotech# ECZ00284) between the VDC power supply's AC inputs and the AC power source.
4. Use the lowest motor voltage required by the application to reduce radiated emission.
5. Use a separate wire for each ground connection to the drive. Use the shortest possible wire length.

For additional iXC2e/XC2e system interconnection information, refer to [Section 2.6. System Interconnection](#).

2.2. Motor Power Output Connector



DANGER: Before you do maintenance to the equipment, disconnect the electrical power. Wait at least one (1) minute after removing the power supply before doing maintenance or an inspection. Otherwise, there is the danger of electric shock.

The drive can be used to drive the following motor types:

- Brushless (refer to [Section 2.2.1.](#))
- DC Brush (refer to [Section 2.2.2.](#))
- Stepper (refer to [Section 2.2.3.](#))

For a complete list of electrical specifications, refer to [Section 1.1.](#)



DANGER: Shock and Fire Hazard



Electrical wiring must be designed and installed in accordance with local electrical safety regulations to prevent the risk of fire and electrical shock.

The 7-pin terminal block style motor output connector is located on the front panel.

Table 2-5: Motor Power Output Connector Pinout

Pin	Description	Connector
	Earth Ground to Motor	
A	Brushless Phase A Motor Lead DC Brush + Stepper	
B	Brushless Phase B Motor Lead Stepper	
C	Brushless Phase C Motor Lead DC Brush - Stepper Return	

Table 2-6: Motor Power Output Mating Connector Ratings

Specification		Description
Type		7-Pin Terminal Block
Part Numbers		Aerotech: ECK02457
		Phoenix: 1839678
Conductor Cross Section	One conductor, stranded with ferrule and plastic sleeve	18...22 AWG (0.25...0.75 mm ²)
	Two conductors (same cross-section), stranded, twin ferrule with plastic sleeve	20 AWG (0.5 mm ²)
Tightening Torque		0.22...0.25 N·m
Conductor Insulation Strip Length		7 mm (0.25 in)
(1) Refer to the manufacturer website for additional information.		

2.2.1. Brushless Motor Connections

The configuration in [Figure 2-3](#) shows a typical brushless motor connection.

Figure 2-3: Brushless Motor Configuration

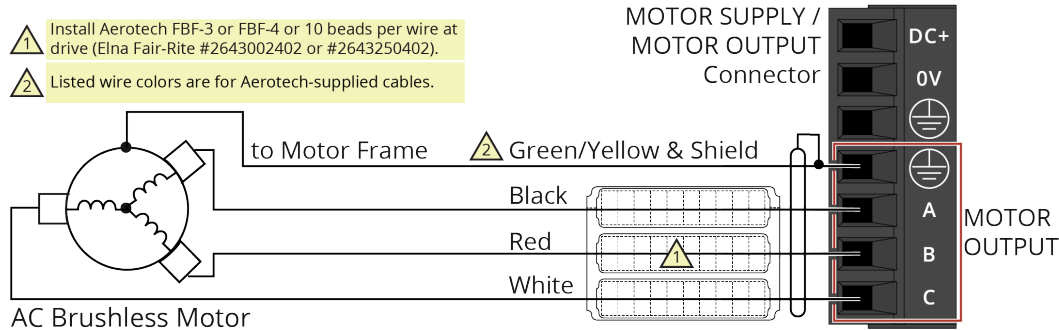

Table 2-7: Wire Colors for Aerotech-Supplied Brushless Motor Cables

Pin	Wire Color Set 1 ⁽¹⁾	Wire Color Set 2	Wire Color Set 3	Wire Color Set 4
⊕	Green/Yellow & Shield ⁽²⁾	Green/Yellow & Shield	Green/Yellow & Shield	Green/Yellow & Shield
A	Black	Blue & Yellow	Black #1	Black & Brown
B	Red	Red & Orange	Black #2	Red & Orange
C	White	White & Brown	Black #3	Violet & Blue

(1) Wire Color Set #1 is the wire set typically used by Aerotech.
 (2) "&" indicates two wires (Red & Orange); "/" indicates a single wire (Green/White).

Brushless motors are commutated electronically by the controller. The use of Hall effect devices for commutation is recommended.

The controller requires that the Back-EMF of each motor phase be aligned with the corresponding Hall-effect signal. To ensure proper alignment, motor, Hall, and encoder connections should be verified using one of the following methods: *powered*, through the use of a test program; or *unpowered* using an oscilloscope. Both methods will identify the A, B, and C Hall/motor lead sets and indicate the correct connections to the controller. Refer to [Section 2.2.1.1.](#) for powered motor phasing or [Section 2.2.1.2.](#) for unpowered motor and feedback phasing.

For Aerotech-supplied systems, the motor, encoder and Hall sensors are correctly configured and connection adjustments are not necessary.

A motor filter module such as the MFM10 can be installed between the drive and the motor, which will reduce the level of PWM amplifier related current spikes in the system.

2.2.1.1. Brushless Motor Powered Motor and Feedback Phasing

Observe the state of the encoder and Hall-effect device signals in the Diagnostics section of the Status Utility.

Table 2-8: Hall Signal Diagnostics

Hall-Signal Status	Definition
--	0 V or logic low
ON	5 V or logic high

Figure 2-4: Positive Motor Direction

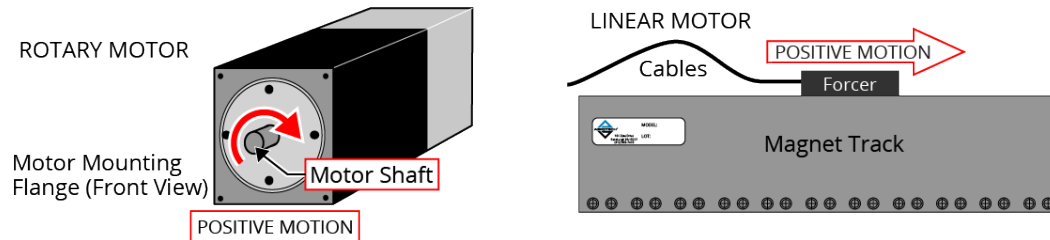
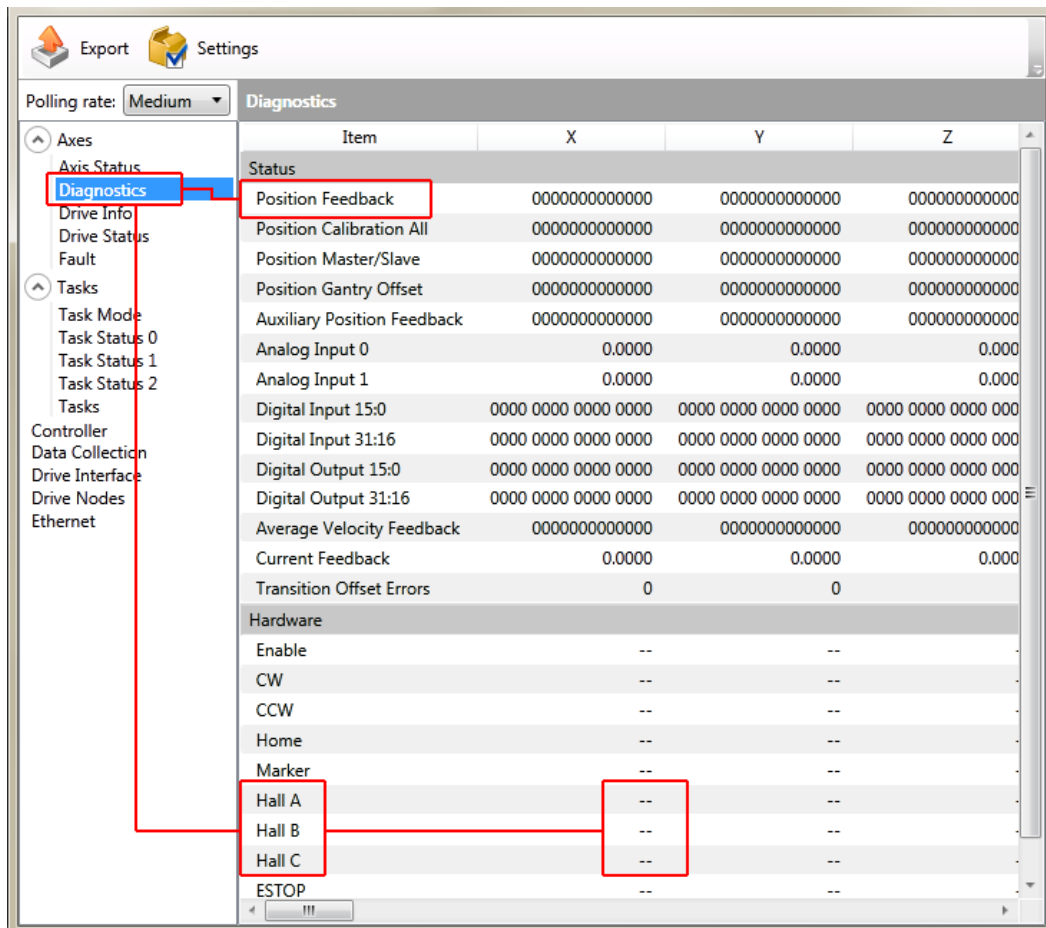

Figure 2-5: Encoder and Hall Signal Diagnostics



2.2.1.2. Brushless Motor Unpowered Motor and Feedback Phasing

Disconnect the motor from the controller and connect the motor in the test configuration shown in Figure 2-6. This method will require a two-channel oscilloscope, a 5V power supply, and six resistors (10,000 ohm, 1/4 watt). All measurements should be made with the probe common of each channel of the oscilloscope connected to a neutral reference test point (TP4, shown in Figure 2-6). Wave forms are shown while moving the motor in the positive direction.

Figure 2-6: Brushless Motor Phasing Oscilloscope Example

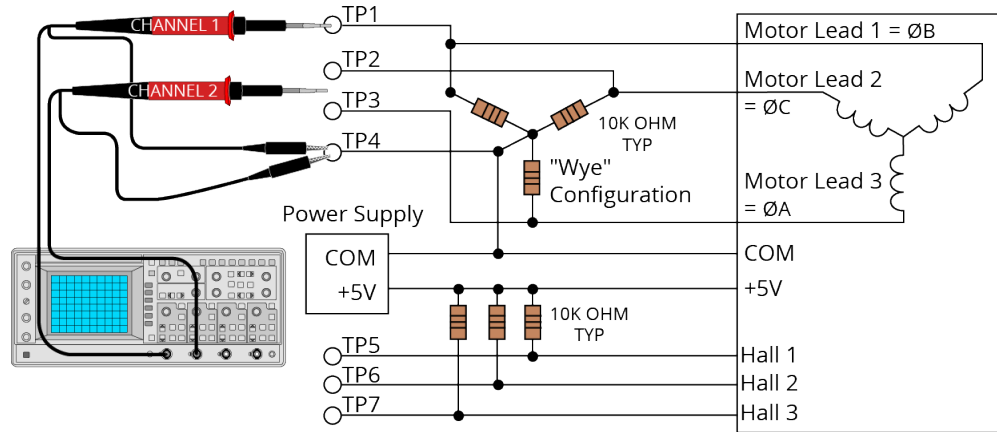

With the designations of the motor and Hall leads of a third party motor determined, the motor can now be connected to an Aerotech system. Connect motor lead A to motor connector A, motor lead B to motor connector B, and motor lead C to motor connector C. Hall leads should also be connected to their respective feedback connector pins (Hall A lead to the Hall A feedback pin, Hall B to Hall B, and Hall C to Hall C). The motor is correctly phased when the Hall states align with the Back EMF as shown in Figure 2-7. Use the CommutationOffset parameter to correct for Hall signal misalignment.

Figure 2-7: Brushless Motor Phasing Goal

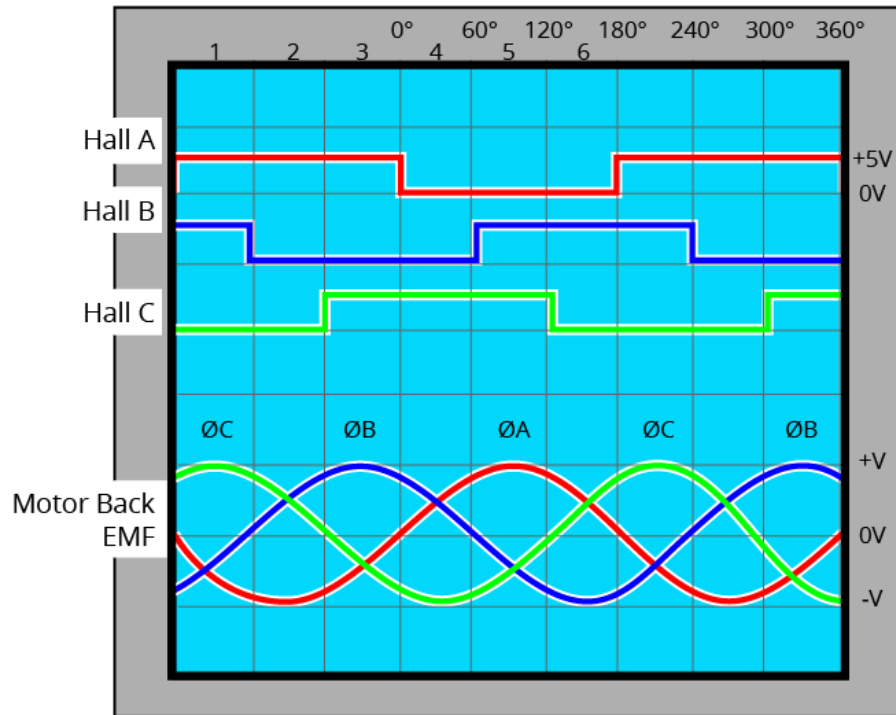

2.2.2. DC Brush Motor Connections

The configuration shown in Figure 2-8 is an example of a typical DC brush motor connection. Refer to Section 2.2.2.1. for information on motor phasing.

Figure 2-8: DC Brush Motor Configuration

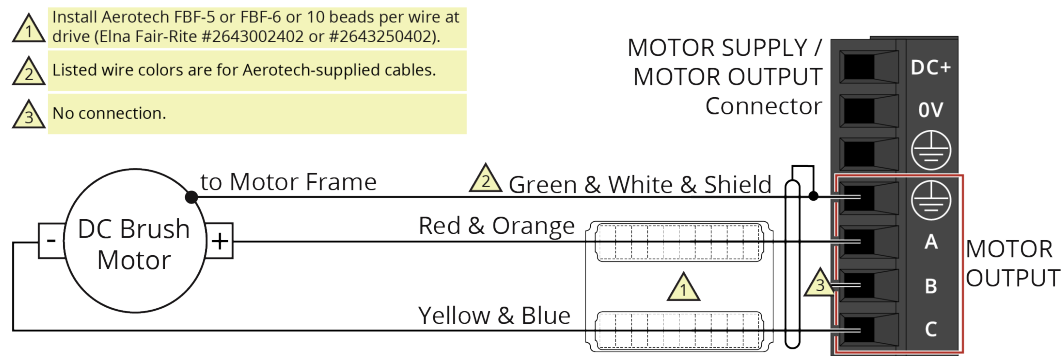

Table 2-9: Wire Colors for Aerotech-Supplied DC Brush Motor Cables

Pin	Wire Color Set 1 ⁽¹⁾	Wire Color Set 2	Wire Color Set 3
⊕	Green & White & Shield ⁽²⁾	Green/Yellow & Shield	Green/Yellow & Shield
A	Red & Orange	Red	Red & Orange
C	Yellow & Blue	Black	Yellow & Blue

(1) Wire Color Set #1 is the typical wire set used by Aerotech.
 (2) "&" (Red & Orange) indicates two wires; "/" (Green/White) indicates a single wire.

2.2.2.1. DC Brush Motor Phasing

A properly phased motor means that the positive motor lead should be connected to the ØA motor terminal and the negative motor lead should be connected to the ØC motor terminal. To determine if the motor is properly phased, connect a voltmeter to the motor leads of an un-powered motor:

1. Connect the positive lead of the voltmeter to the one of the motor terminals.
2. Connect the negative lead of the voltmeter to the other motor terminal.
3. Move or rotate the motor in the positive or clockwise (CW) direction by hand.

Figure 2-9: Positive Motor Direction

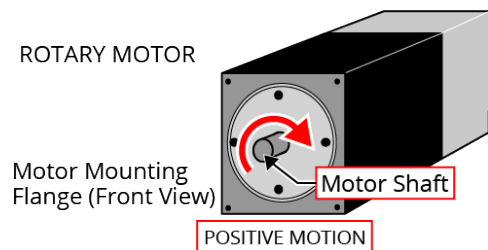

4. If the voltmeter indicates a negative value, swap the motor leads and move the motor by hand in the positive direction, again. When the voltmeter indicates a positive value, the motor leads have been identified.
5. Connect the motor lead from the positive lead of the voltmeter to the ØA motor terminal on the drive. Connect the motor lead from the negative lead of the voltmeter to the ØC motor terminal on the drive.

For Aerotech-supplied systems, the motor, encoder and Hall sensors are correctly configured and connection adjustments are not necessary.

2.2.3. Stepper Motor Connections

The configuration shown in Figure 2-10 is an example of a typical stepper motor connection. Refer to Section 2.2.3.1. for information on motor phasing.

In this case, the effective motor voltage is half of the applied bus voltage. For example, an 80 V motor bus supply is needed to get 40 V across the motor.

Figure 2-10: Stepper Motor Configuration

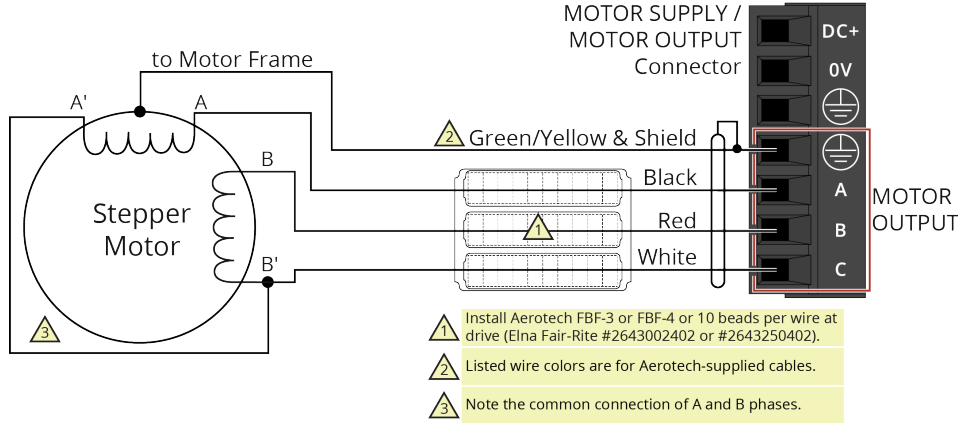

Table 2-10: Wire Colors for Aerotech-Supplied Stepper Motor Cables

Pin	Wire Color Set 1 ⁽¹⁾	Wire Color Set 2
⊕	Green/Yellow & Shield ⁽²⁾	Green/Yellow & Shield
A	Black	Brown
B	Red	Yellow
C	White	White & Red

(1) Wire Color Set #1 is the typical wire set used by Aerotech.
 (2) "&" (Red & Orange) indicates two wires; "/" (Green/White) indicates a single wire.

2.2.3.1. Stepper Motor Phasing

A stepper motor can be run with or without an encoder.

Without an Encoder: You do not need to phase the motor.

With an Encoder: Because the end of travel (EOT) limit inputs are relative to motor rotation, it is important to phase the motor.

Run a positive motion command. The motor is phased correctly if there is a positive scaling factor (determined by the ServoLoopSetup parameter) and the motor moves in a clockwise direction when you view the motor from the front mounting flange (Figure 2-11). If the motor moves in a counterclockwise direction, reverse the motor leads and re-run the command. After the motor has been phased, if you want to change the direction of positive motion, use the ReverseMotionDirection parameter.

Figure 2-11: Positive Motor Direction

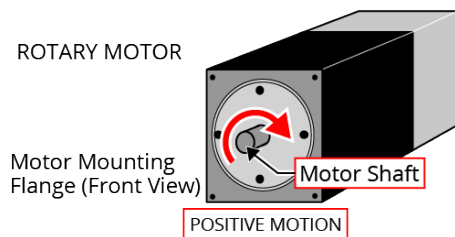

For Aerotech-supplied systems, the motor, encoder and Hall sensors are correctly configured and connection adjustments are not necessary.

2.2.4. Three Phase Stepper Motor Connections



IMPORTANT: This feature is only supported in Automation1 software version 2.2.0. or later.

The configuration shown in Figure 2-12 is an example of a typical three phase stepper motor connection. Refer to Section 2.2.4.1. for information on motor phasing.

Figure 2-12: Stepper Motor Configuration

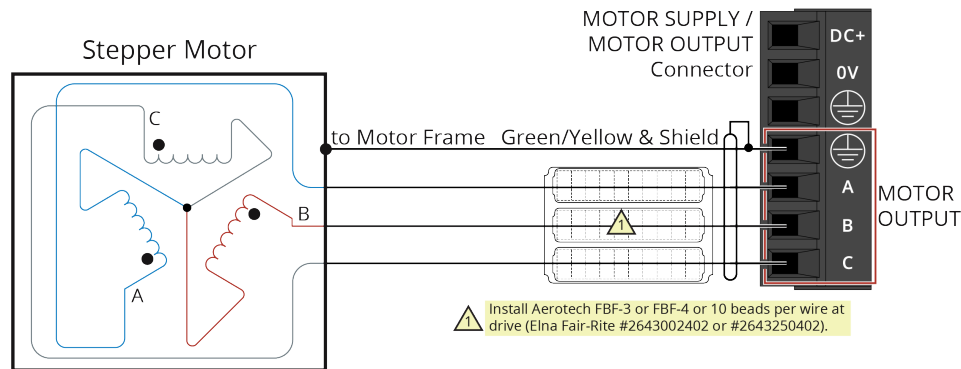

2.2.4.1. Stepper Motor Phasing

A three phase stepper motor can be run with or without an encoder.

Without an Encoder: You do not need to phase the motor.

With an Encoder: Because the end of travel (EOT) limit inputs are relative to motor rotation, it is important to phase the motor.

Run a positive motion command. The motor is phased correctly if there is a positive scaling factor (determined by the ServoLoopSetup parameter) and the motor moves in a clockwise direction when you view the motor from the front mounting flange (Figure 2-13). If the motor moves in a counterclockwise direction, reverse the motor leads and re-run the command. After the motor has been phased, if you want to change the direction of positive motion, use the ReverseMotionDirection parameter.

Figure 2-13: Positive Motor Direction

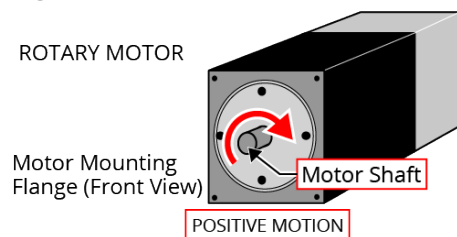

2.3. Feedback Connector

The connector pin assignment is shown in [Table 2-11](#) with detailed connection information in the following sections.

Table 2-11: Feedback Connector Pinout

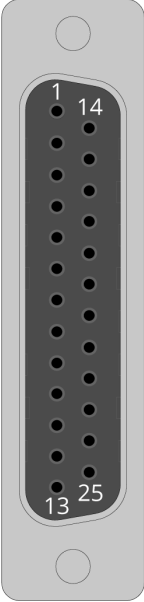
Pin #	Description	In/Out/Bi	Connector
1	Reserved	N/A	
2	Motor Over Temperature Thermistor	Input	
3	+5V Power ⁽¹⁾	Output	
4	Plug and Play Serial Data (for Aerotech stages only)	Bidirectional	
5	Hall-Effect Sensor B (brushless motors only)	Input	
6	Encoder Marker Reference Pulse -	Input	
	Absolute Encoder Clock -	Output	
7	Encoder Marker Reference Pulse +	Input	
	Absolute Encoder Clock +	Output	
8	Absolute Encoder Data -	Bidirectional	
9	Reserved	N/A	
10	Hall-Effect Sensor A (brushless motors only)	Input	
11	Hall-Effect Sensor C (brushless motors only)	Input	
12	Clockwise End of Travel Limit	Input	
13	Brake Output -	Output	
14	Encoder Cosine +	Input	
15	Encoder Cosine -	Input	
16	+5V Power ⁽¹⁾	Output	
17	Encoder Sine +	Input	
18	Encoder Sine -	Input	
19	Absolute Encoder Data+	Bidirectional	
20	Signal Common	Output	
21	Signal Common	Output	
22	Home Switch Input	Input	
23	Encoder Fault Input	Input	
24	Counterclockwise End of Travel Limit	Input	
25	Brake Output +	Output	

(1) The maximum combined current output is 500 mA.

Table 2-12: Feedback Mating Connector Ratings

Specification	25-Pin Solder Cup	Backshell
Aerotech Part Number	ECK00101	ECK00656
Amphenol Part Number ⁽¹⁾	DB25P064TXLF	17E-1726-2
Maximum Wire Size	20 AWG (0.5 mm ²)	N/A

(1) Refer to the manufacturer website for additional information.

2.3.1. Primary Encoder Inputs

The primary encoder inputs are accessible through the Feedback connector. Use the PrimaryFeedbackType parameter to configure the drive to accept an encoder signal type.

Square Wave encoder signals: [Section 2.3.1.1.](#)

Absolute encoder signals: [Section 2.3.1.2.](#)

Sine Wave encoder signals (as permitted by the multiplier option): [Section 2.3.1.3.](#)

Refer to [Section 2.3.1.4.](#) for encoder feedback phasing.

Refer to [Section 3.2.](#) for the auxiliary encoder on the AUX connector.

Table 2-13: Multiplier Options

Option	Primary Encoder Accepts...	Auxiliary Encoder Accepts...
-MX0	Square Wave or Absolute encoders	Square Wave encoders
-MX2	Sine Wave (high performance), Square Wave, or Absolute encoders	Square Wave encoders
-MX3	Sine Wave (high performance), Square Wave, or Absolute encoders	Sine Wave (standard performance) or Square Wave encoders



IMPORTANT: Physically isolate the encoder wiring from motor, AC power, and all other power wiring

Table 2-14: Primary Encoder Pins on the Feedback Connector

Pin #	Description	In/Out/Bi
3	+5V Power ⁽¹⁾	Output
6	Encoder Marker Reference Pulse -	Input
	Absolute Encoder Clock -	Output
7	Encoder Marker Reference Pulse +	Input
	Absolute Encoder Clock +	Output
8	Absolute Encoder Data -	Bidirectional
14	Encoder Cosine +	Input
15	Encoder Cosine -	Input
16	+5V Power ⁽¹⁾	Output
17	Encoder Sine +	Input
18	Encoder Sine -	Input
19	Absolute Encoder Data+	Bidirectional
20	Signal Common	Output
21	Signal Common	Output

(1) The maximum combined current output is 500 mA.

2.3.1.1. Square Wave Encoder (Primary)

The drive accepts RS-422 square wave encoder signals. The drive will generate a feedback fault if it detects an invalid signal state caused by an open or shorted signal connection. Use twisted-pair wiring for the highest performance and noise immunity.

Table 2-15: Square Wave Encoder Specifications

Specification	Value
Encoder Frequency	10 MHz maximum (25 ns minimum edge separation)
x4 Quadrature Decoding	40 million counts/sec

Figure 2-14: Square Wave Encoder Schematic (Feedback Connector)

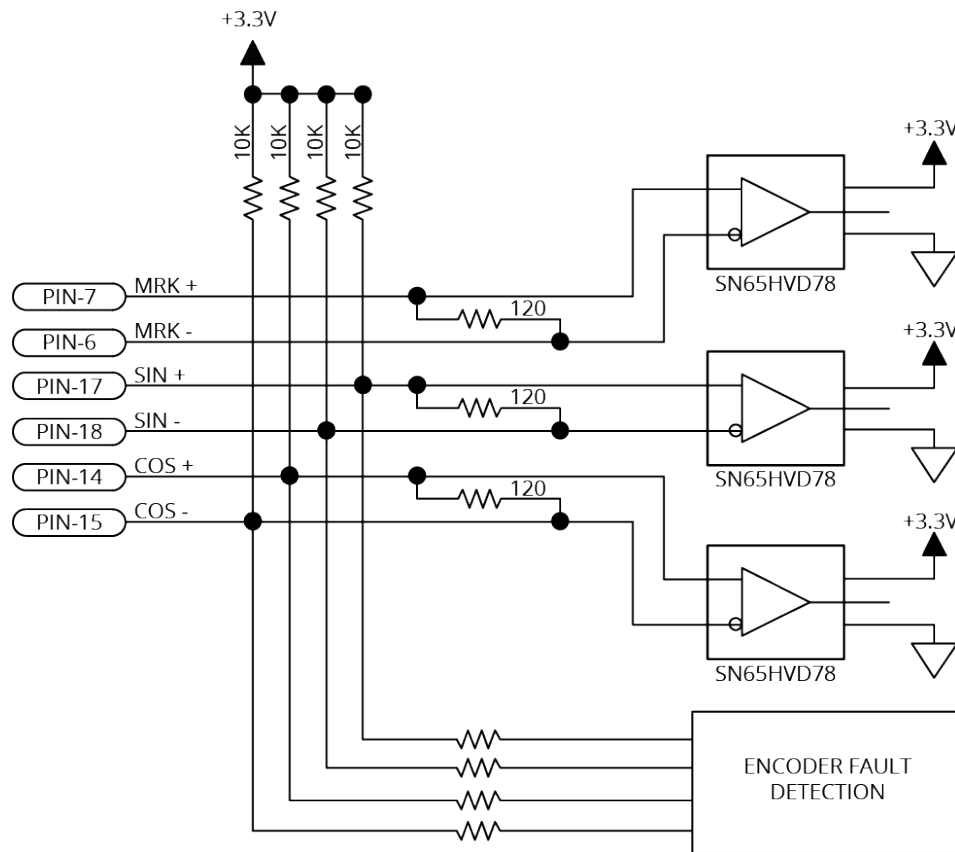

2.3.1.2. Absolute Encoder (Primary)

The drive retrieves absolute position data along with encoder fault information through a serial data stream from the absolute encoder. Use twisted-pair wiring for the highest performance and noise immunity. You cannot echo an absolute encoder signal.

Refer to [Figure 2-15](#) for the serial data stream interface.

Refer to the [Help file](#) for information on how to set up your EnDat or BiSS absolute encoder parameters.

Figure 2-15: Absolute Encoder Schematic (Feedback Connector)

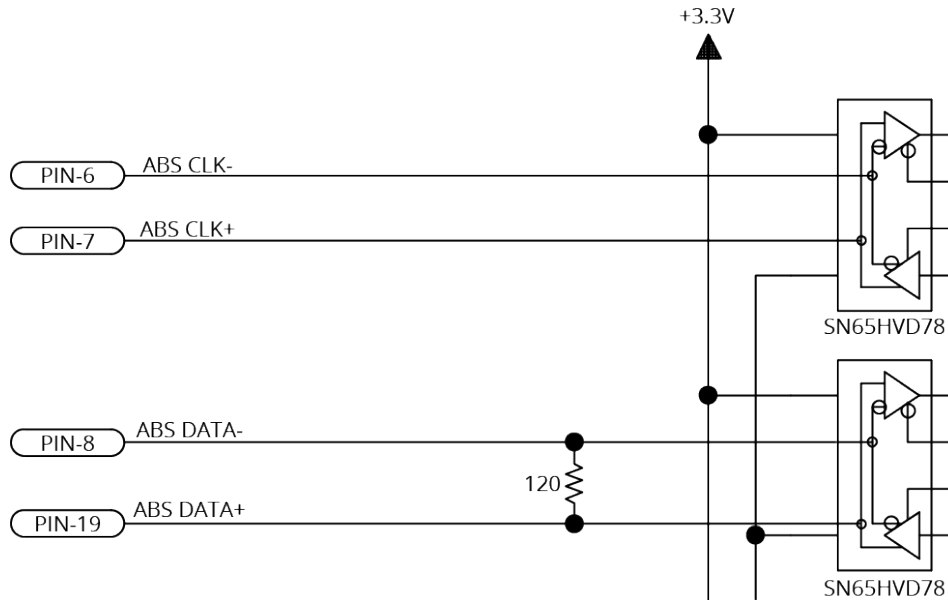

2.3.1.3. Sine Wave Encoder (Primary) [-MX2/-MX3 Option]

The Sine Wave Encoder option provides higher positioning resolution by subdividing the fundamental output period of the encoder into smaller increments. The amount of subdivision is specified by the PrimaryEncoderMultiplicationFactor parameter. Use Encoder Tuning to adjust the value of the gain, offset, and phase balance controller parameters to get the best performance. For more information, refer to the [Help file](#).

High resolution or high-speed encoders can require increased bandwidth for correct operation. Use the High Speed Mode of the PrimaryEncoderMultiplierSetup parameter to enable the high bandwidth mode. Because this mode increases sensitivity to system noise, use it only if necessary. This option is only available on the Primary encoder input.

The drive can generate emulated encoder signals. These signals can be output on the Auxiliary Encoder (AUX) connector or used internally by the PSO. Refer to the EncoderDivider and PrimaryEmulatedQuadratureDivider parameters and the encoder output functions in the Help file for more information.

For the highest performance, use twisted pair double-shielded cable with the inner shield connected to signal common and the outer shield connected to frame ground. Do not join the inner and outer shields in the cable.

Table 2-16: Sine Wave Encoder Specifications

Specification	Value	
	Primary	Auxiliary
Input Frequency (max)	200 kHz, 2 MHz	200 kHz
Input Amplitude ⁽¹⁾	0.6 to 1.75 Vpk-pk	
Interpolation Factor (max)	-MX2	65,536
	-MX3	65,536
-MX2/-MX3 Primary Encoder Channel Interpolation Latency	800 nsec (analog input to quadrature output)	
Input Common Mode	1.5 to 3.5 VDC	
<small>(1) Measured as SIN(+) - SIN(-) or COS(+) - COS(-)</small>		

Figure 2-16: Sine Wave Encoder Phasing Reference Diagram

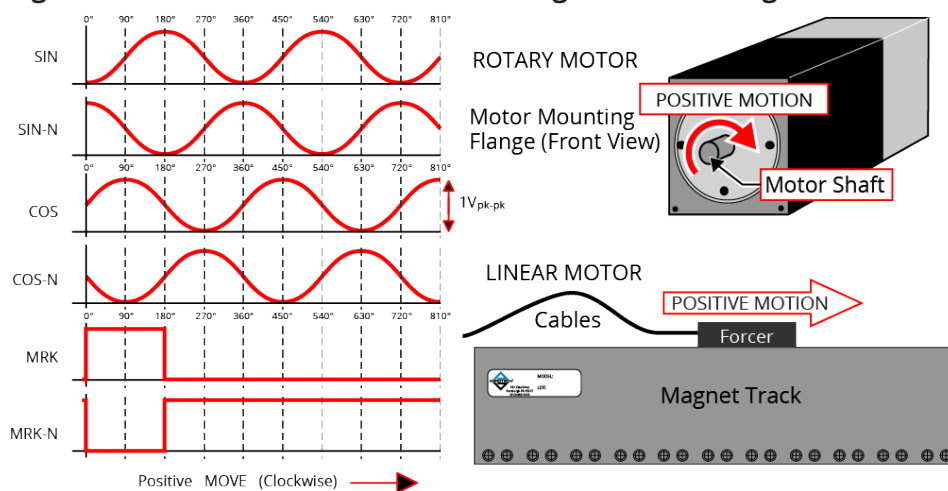
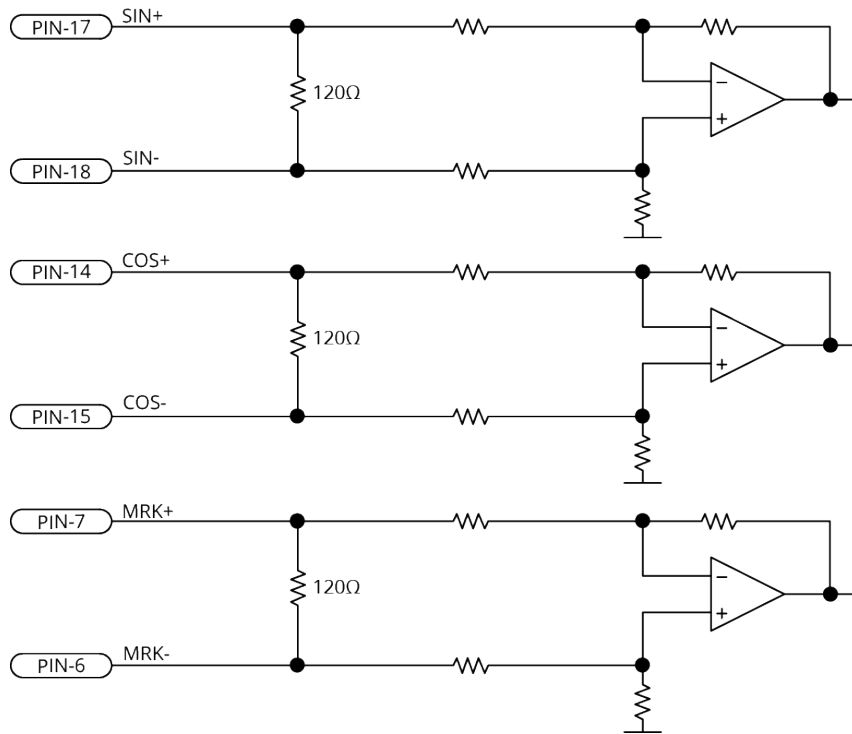

Figure 2-17: Sine Wave Encoder Schematic (Feedback Connector)

2.3.1.4. Encoder Phasing

Incorrect encoder polarity will cause the system to fault when enabled or when a move command is issued. [Figure 2-18](#) illustrates the proper encoder phasing for clockwise motor rotation (or positive forcer movement for linear motors). To verify, move the motor by hand in the CW (positive) direction while observing the position of the encoder in the diagnostics display (see [Figure 2-19](#)).

For dual loop systems, the velocity feedback encoder is displayed in the diagnostic display ([Figure 2-19](#)).

Figure 2-18: Encoder Phasing Reference Diagram (Standard)

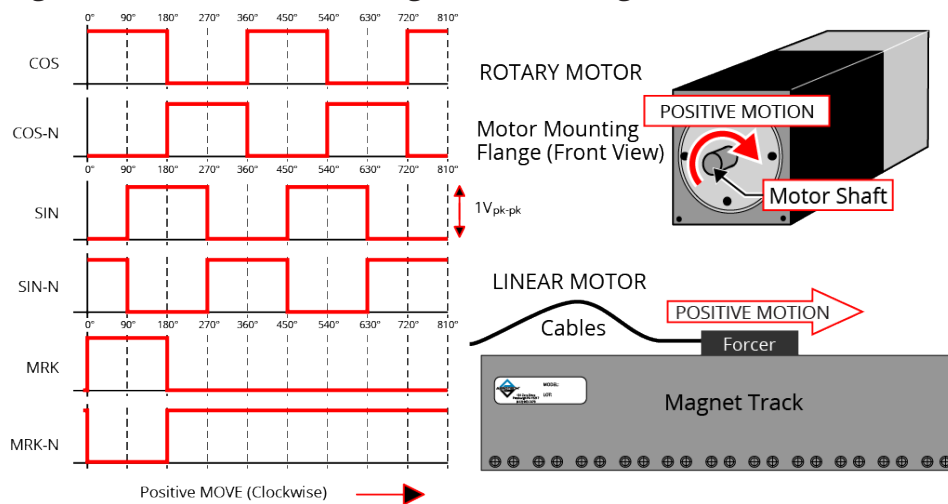

IMPORTANT: Encoder manufacturers may refer to the encoder signals as A, B, and Z. The proper phase relationship between signals is shown in [Figure 2-18](#).

Figure 2-19: Position Feedback in the Diagnostic Display

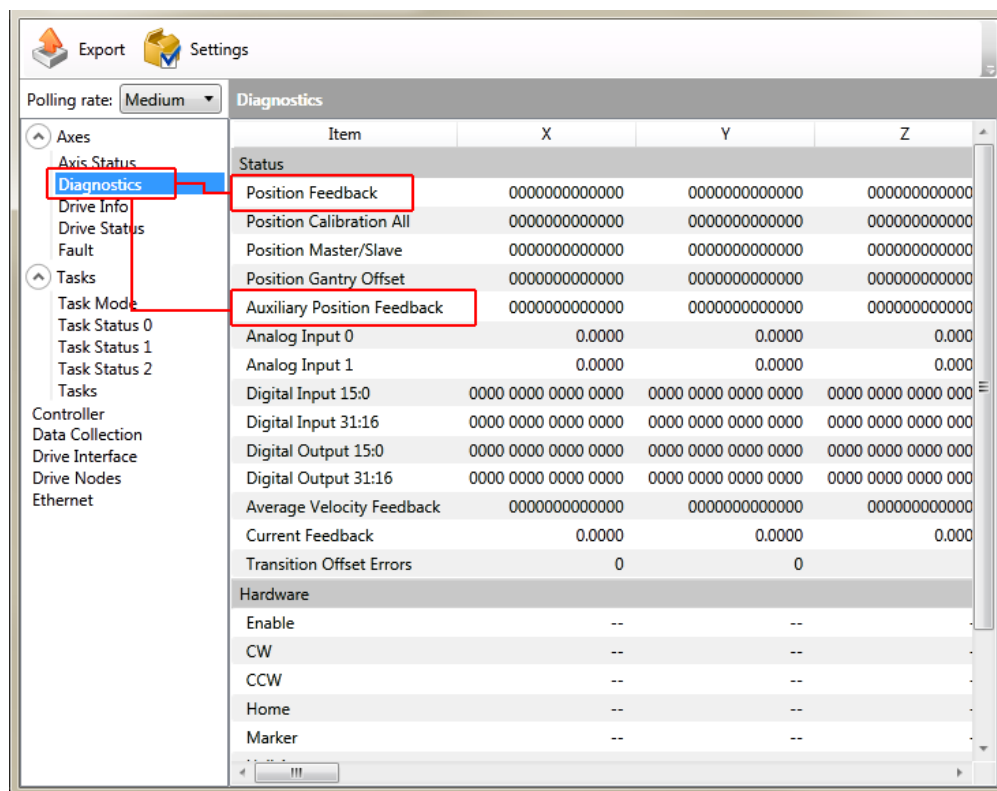

2.3.2. Hall-Effect Inputs

The Hall-effect switch inputs are recommended for AC brushless motor commutation but not absolutely required. The Hall-effect inputs accept 5 VDC level signals. Hall states (0,0,0) or (1,1,1) are invalid and will generate a "Hall Fault" axis fault.

Refer to [Section 2.2.1.1](#), for Hall-effect device phasing.

Table 2-17: Hall-Effect Feedback Pins on the Feedback Connector

Pin #	Description	In/Out/Bi
3	+5V Power ⁽¹⁾	Output
5	Hall-Effect Sensor B (brushless motors only)	Input
10	Hall-Effect Sensor A (brushless motors only)	Input
11	Hall-Effect Sensor C (brushless motors only)	Input
16	+5V Power ⁽¹⁾	Output
20	Signal Common	Output
21	Signal Common	Output

(1) The maximum combined current output is 500 mA.

Figure 2-20: Hall-Effect Inputs Schematic (Feedback Connector)

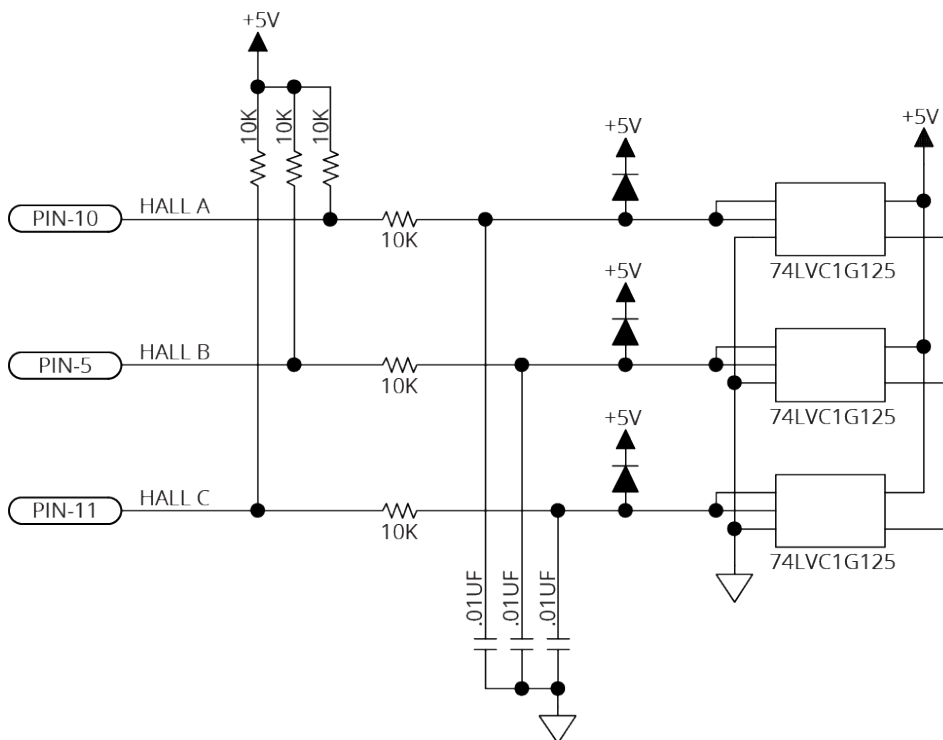

2.3.3. Thermistor Input

The thermistor input is used to detect a motor over temperature condition by using a positive temperature coefficient sensor. As the temperature of the sensor increases, so does the resistance. Under normal operating conditions, the resistance of the thermistor is low which will result in a low input signal. As the increasing temperature causes the resistance of the thermistor to increase, the sensor will trigger an over temperature fault.

The thermistor is connected between Pin 2 and Signal Common. The nominal trip value of the sensor is 1.385 k Ω . The circuit includes a 12 k Ω internal pull-up resistor which corresponds to a trip voltage of +0.52 V.

Table 2-18: Thermistor Input Pin on the Feedback Connector

Pin #	Description	In/Out/Bi
2	Motor Over Temperature Thermistor	Input

Figure 2-21: Thermistor Input Schematic (Feedback Connector)

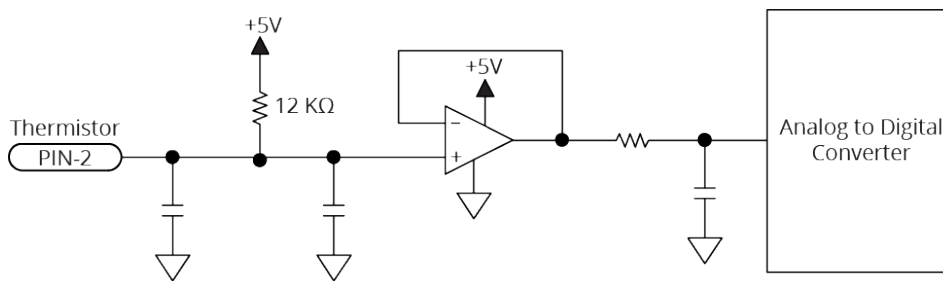

2.3.4. Encoder Fault Input

The encoder fault input is for use with encoders that have a fault output. This is provided by some manufacturers and indicates a loss of encoder function. The active state of this input is parameter configurable and the controller should be configured to disable the axis when the fault level is active. The nominal trip voltage of the encoder fault input is +2.5 V.

Table 2-19: Encoder Fault Input Pin on the Feedback Connector

Pin #	Description	In/Out/Bi
23	Encoder Fault Input	Input

Figure 2-22: Encoder Fault Input Schematic (Feedback Connector)

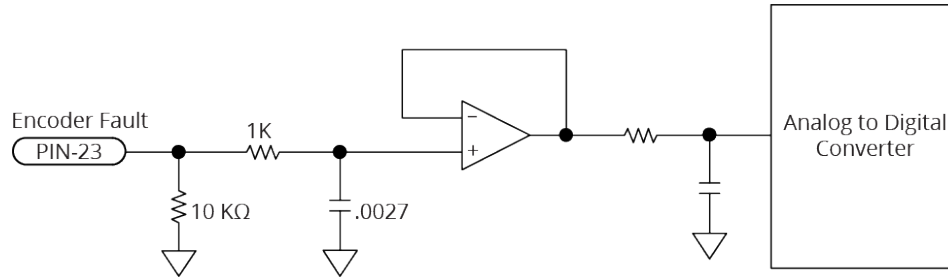

2.3.5. End of Travel and Home Limit Inputs

End of Travel (EOT) limits are required to define the end of the physical travel on linear axes. Positive or clockwise motion is stopped by the clockwise (CW) end of travel limit input. Negative or counterclockwise motion is stopped by the counterclockwise (CCW) end of travel limit input. The Home Limit switch can be parameter configured for use during the home cycle, however, the CW or CCW EOT limit is typically used instead. All of the end-of-travel limit inputs accept 0-24 VDC level signals. Limit directions are relative to the encoder polarity in the diagnostics display (refer to [Figure 2-25](#)).

Table 2-20: End of Travel and Home Limit Pins on the Feedback Connector

Pin #	Description	In/Out/Bi
12	Clockwise End of Travel Limit	Input
16	+5V Power	Output
20	Signal Common	Output
21	Signal Common	Output
22	Home Switch Input	Input
24	Counterclockwise End of Travel Limit	Input

The active state (High/Low) of the EOT limits is software selectable (by the EndOfTravelLimitSetup axis parameter). [Figure 2-23](#) shows the possible wiring configurations for normally-open and normally-closed switches and the parameter setting to use for each configuration.



IMPORTANT: Use NPN-type normally-closed limit switches (Active High) to provide fail-safe behavior in the event of an open circuit.

Figure 2-23: End of Travel and Home Limit Input Connections

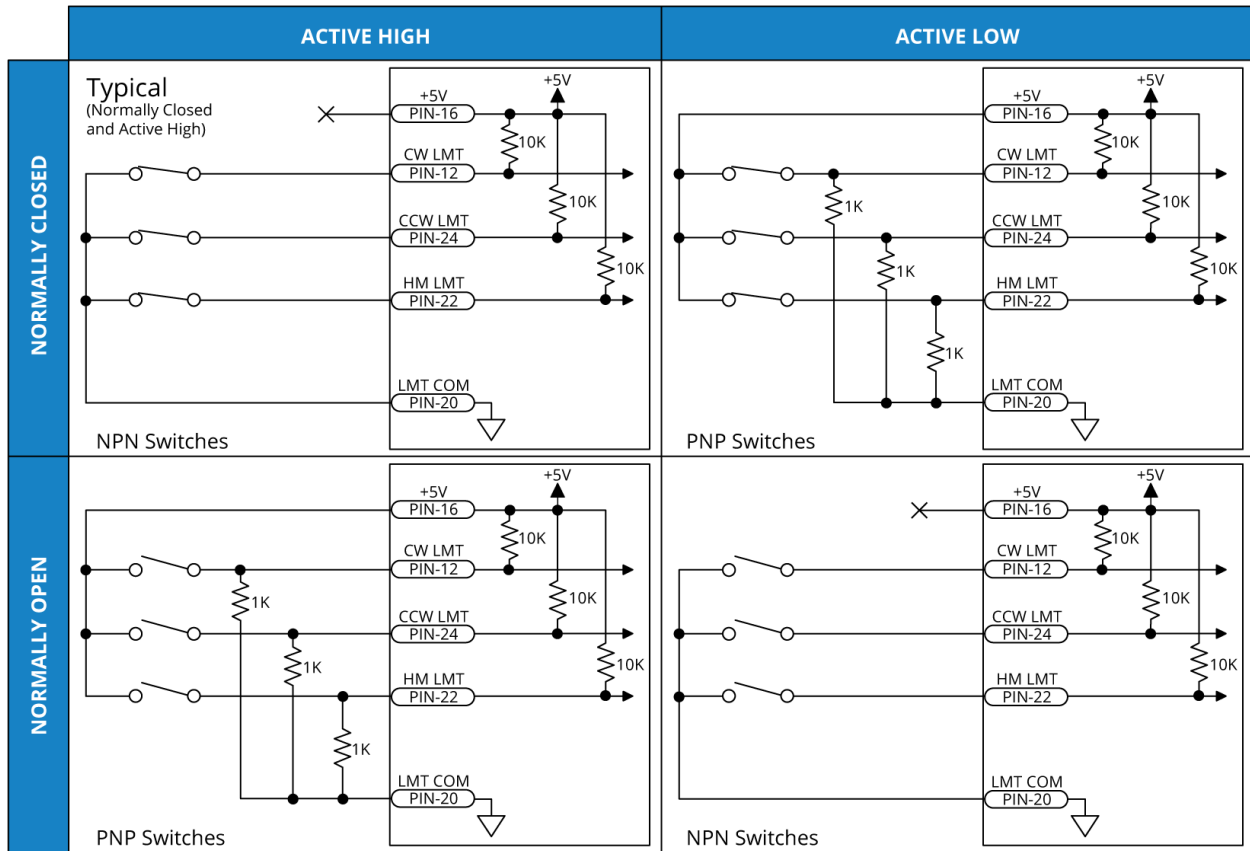
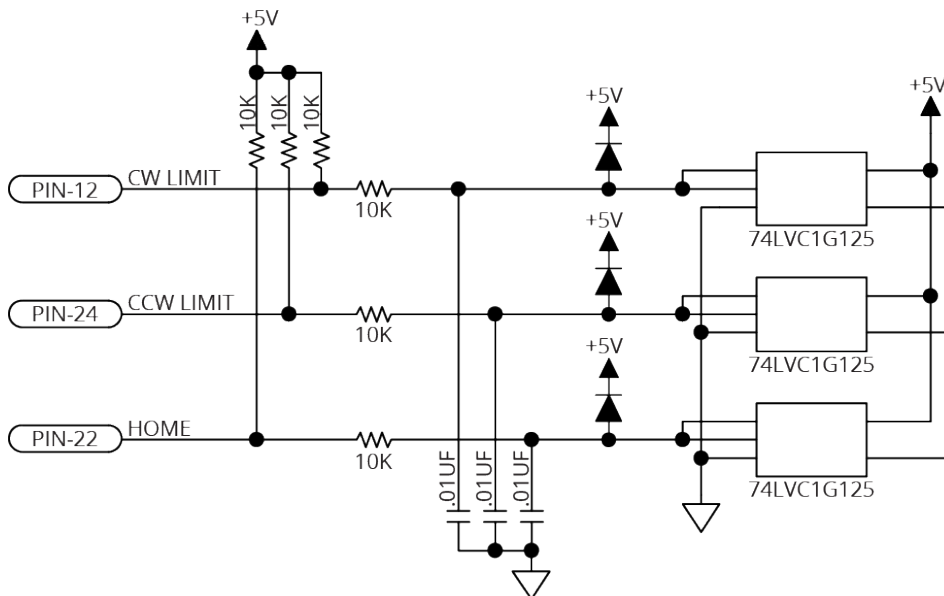

Figure 2-24: End of Travel and Home Limit Input Schematic (Feedback Connector)



2.3.5.1. End of Travel and Home Limit Phasing

If the EOT limits are reversed, you will be able to move further into a limit but be unable to move out. To correct this, swap the connections to the CW and CCW inputs at the Feedback connector or swap the CW and CCW limit functionality in the software using the EndOfTravelLimitSetup parameter. View the logic level of the EOT limit inputs in the Diagnostics display (shown in [Figure 2-25](#)).

Figure 2-25: End of Travel and Home Limit Input Diagnostic Display

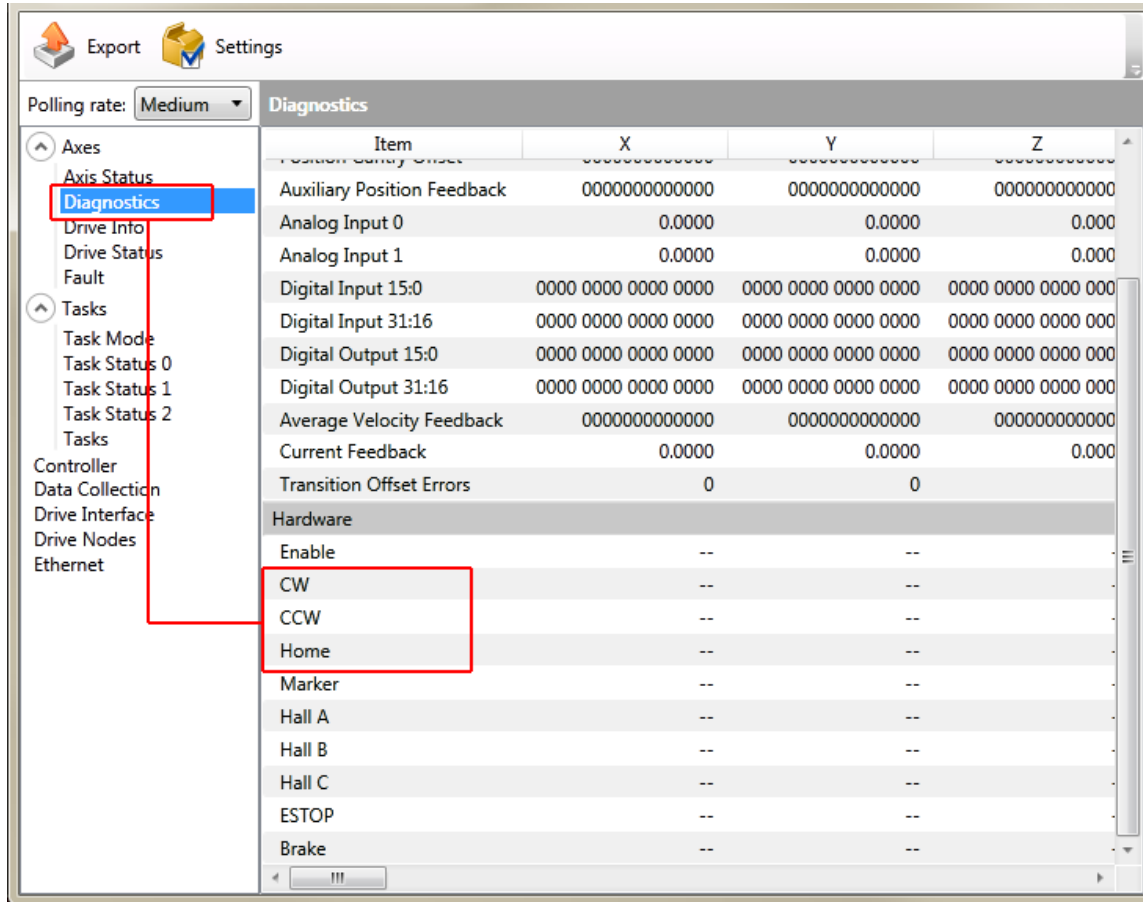

2.3.6. Brake Outputs

The drive has a dedicated brake control circuit. Configure the brake with the BrakeSetup parameter for automatic control (typical). You can also use software commands to directly control the brake output.

Table 2-21: Brake Output Pins on the Feedback Connector

Pin #	Description	In/Out/Bi
13	Brake Output -	Output
25	Brake Output +	Output

Table 2-22: Brake Control Specifications

Specification	Value
Maximum Voltage	24 VDC
Maximum Current	1 A

A varistor must be connected across the brake to minimize voltage transients.

Figure 2-26: Brake Connected to the 25-Pin Feedback Connector (Typical)

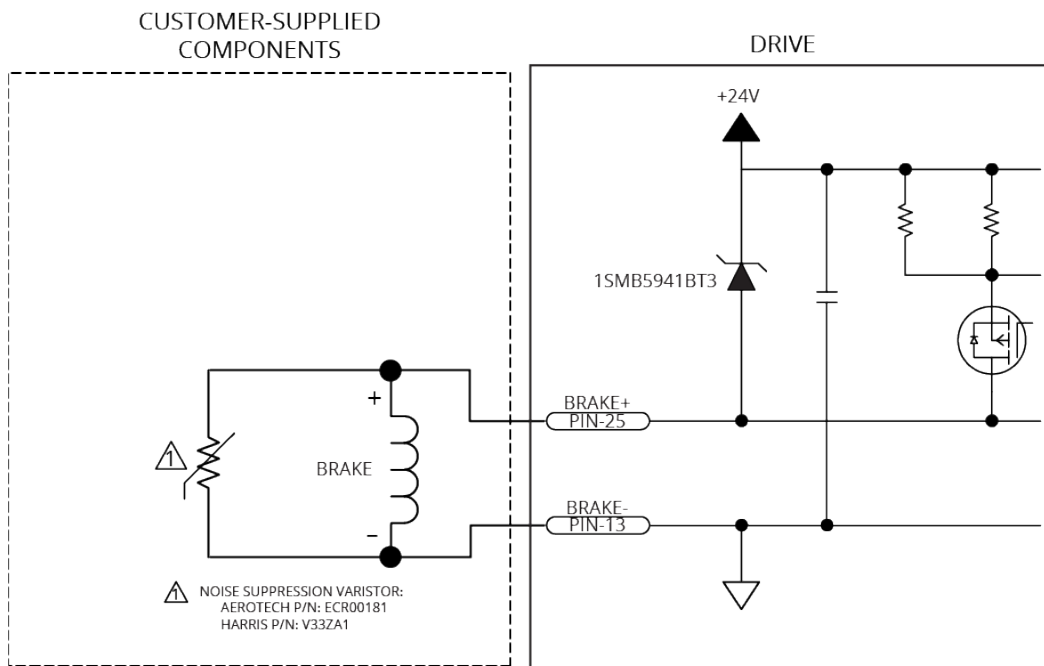

2.4. Safe Torque Off Input (STO)



IMPORTANT: The safety components (STO) certification is pending for the iXC2e.

The STO circuit is comprised of two identical channels, each of which must be energized in order for the drive to produce motion. Each STO input is opto-isolated and accepts 24 V levels directly without the need for external current limiting resistors.



IMPORTANT: The drive might be equipped with an STO bypass circuit board. The bypass circuit board defeats the STO safety circuit and allows the system to run at all times. To use the STO safety functionality, remove the circuit board and make connections as outlined in this section.



IMPORTANT: The application circuit and its suitability for the desired safety level is the sole responsibility of the user of the drive.



WARNING: STO wires must be insulated to prevent short circuits between connector pins. The primary concern is a short circuit between STO 1 IN and STO 2 IN wire strands.

Table 2-23: STO Connector Pinout

Pin #	Signal	Description	In/Out/Bi	Connector
1	Power Supply +	Use only to defeat STO by connecting to STO 1 IN and STO 2 IN. Not for customer use.	Output	
2	STO 1 IN	STO Channel 1 Positive Input	Input	
3	RETURN	STO Negative Input	Input	
4	STO 2 IN	STO Channel 2 Positive Input	Input	
5	Power Supply -	Use only to defeat STO by connecting to RETURN. Not for customer use.	Output	

Table 2-24: STO Mating Connector Ratings

Specification		Description
Type		5-Pin Terminal Block
Part Numbers		Aerotech: ECK02393 Phoenix: 1827622
Conductor Cross Section	One conductor, stranded with ferrule and plastic sleeve	18...22 AWG (0.25...0.75 mm ²)
	Two conductors (same cross-section), stranded, twin ferrule with plastic sleeve	20 AWG (0.5 mm ²)
Tightening Torque		0.22...0.25 N·m
Conductor Insulation Strip Length		7 mm (0.25 in)

(1) Refer to the manufacturer website for additional information.

Table 2-25: STO Electrical Specifications

Status	Value
STO off (motion allowed)	18-24 V, 7 ma
STO on (safe state entered, no motion)	0-6 V
Recommended Wire Gauge	22-26 AWG (0.5 - 0.14 mm ²)
STO System Power Supply	PELV
STO Wire Length (maximum)	50 m

Figure 2-27 shows one safety device connected to multiple drives in parallel.



WARNING: The drive does not check for short circuits on the external STO wiring. If this is not done by the external safety device, short circuits on the wiring must be excluded. Refer to EN ISO 13849-2. For Category 4 systems, the exclusion of short circuits is mandatory.

Figure 2-27: Typical STO Configuration

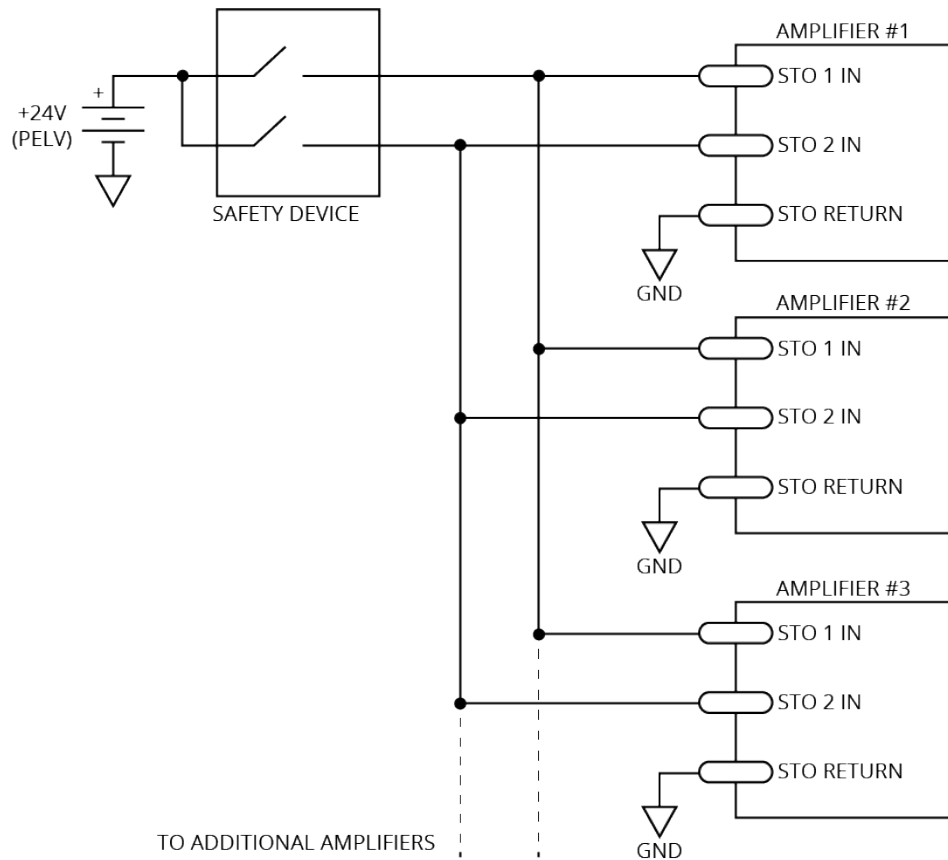

2.4.1. STO Standards

Table 2-26 describes and specifies the safety requirements at the system level for the Safe Torque Off (STO) feature of the drive. This assumes that diagnostic testing is performed according to Section 2.4.4. and Table 2-27.

Table 2-26: STO Standards

Standard	Maximum Achievable Safety
EN/IEC 61800-5- 2:2016	SIL 3
EN/IEC 61508-1:2010	SIL 3
EN/IEC 61508-2:2010	SIL 3
EN ISO 13849-1:2015	Category 4, PL e
EN/IEC 62061:2005 with Amendments	SIL 3

Table 2-27: STO Standards Data

Standard	Value
EN ISO 13849-1:2015	MTTF _D > 1000 years, DC _{AVG} 99% Maximum PL e, Category 4
EN ISO 13849-1:2015 EN/IEC 61508	Lifetime = 20 years No proof test required Interval for manual STO test: <ul style="list-style-type: none"> • Once per year for SIL2/PL d/category 3 • Once per three months for SIL3/PL e/category 3 • Once per day for SIL3/PL e/category 4
EN/IEC 61508	SIL3 PFH < 3 FIT SFF > 99%

2.4.2. STO Functional Description

The motor can only be activated when voltage is applied to both STO 1 and STO 2 inputs. The STO state will be entered if power is removed from either the STO 1 or the STO 2 inputs. When the STO state is entered, the motor cannot generate torque or force and is therefore considered safe.

The STO function is implemented with two redundant channels in order to meet stated performance and SIL levels. STO 1 disconnects the high side power amplifier transistors and STO 2 disconnects the low side power amplifier transistors. Disconnecting either set of transistors effectively prevents the drive from being able to produce motion.

The drive software monitors each STO channel and will generate an Emergency Stop software fault when either channel signals the stop state. Each STO channel contains a fixed delay which allows the drive to perform a controlled stop before the power amplifier transistors are turned off.

A typical configuration requiring a controlled stop has the Emergency Stop Fault mask bit set in the FaultMask, FaultMaskDecel, and FaultMaskDisable parameters. This stops the axis using the rate specified by the AbortDecelRate parameter. The software will disable the axis as soon as the deceleration ramp is complete. This is typically configured to occur before the STO channel turns off the power amplifier transistors.

The software controlled stop functionality must be excluded when considering overall system safety. This is because the software is not safety rated and cannot be included as part of the safety function.

The drive will tolerate short diagnostic pulses on the STO 1+ and STO 2+ inputs. The parameter "STOPulseFilter" specifies the maximum pulse width that the drive will ignore.

To resume normal operation, apply power to both STO 1 and STO 2 inputs and use the *Acknowledge All* button or the AcknowledgeAll() or FaultAcknowledge() function to clear the Emergency Stop software fault. The recommended use of the Emergency Stop Fault fault mask bits prevent the system from automatically restarting.

You can achieve longer delay times through the use of an external delay timer, such as the Omron G9SA-321 Safety Relay Unit. Place this device between the system ESTOP wiring and the drive's STO inputs. Connect the ESTOP signal directly to a digital input, in addition to the external timer, to allow the drive to begin a software-controlled stop as soon as the ESTOP signal becomes active. Use the EmergencyStopFaultInput parameter to configure a digital input as an ESTOP input.

Non-standard STO delay times are provided by special factory order. In this case, the non-standard STO delay time is indicated by a label placed on the slice amplifier's main connector (STO DELAY = xx sec).

Table 2-28: STO Signal Delay

	Value
STO Time Delay	450-550 msec

Table 2-29: Motor Function Relative to STO Input State

STO 1	STO 2	Motor Function
Unpowered	Unpowered	No force/torque
Unpowered ⁽¹⁾	Powered ⁽¹⁾	No force/torque
Powered ⁽¹⁾	Unpowered ⁽¹⁾	No force/torque
Powered	Powered	Normal Operation

1. This is considered a Fault Condition since STO 1 and STO 2 do not match. Refer to [Section 2.4.4](#).

2.4.3. STO Startup Validation Testing

Verify the state of the STO 1 and STO 2 channels by manually activating the external STO hardware. Each STO channel must be tested separately in order to detect potential short circuits between the channels. The current state of the STO 1 and STO 2 inputs is shown in the Status Utility. A “-” indicates that the STO input is powered by a high voltage level (24 V). An “ON” indicates that the voltage source has been removed from the input (open circuit or 0 V), and that the STO channel is in the safe state.



DANGER: The STO circuit does not remove lethal voltage from the motor terminals. AC mains power must be removed before servicing.

2.4.4. STO Diagnostics

Activation of STO means removing power from the drive's STO inputs. This is typically done by pressing the emergency stop switch. The drive initiates a diagnostic check every time the STO is activated after the Diagnostic Test Delay Time has elapsed. The diagnostic check verifies that each channel has entered the safe state. The drive is held in the safe state if it determines that one of the channels has not properly entered the safe state. An open circuit or short to 24 V in either STO channel will result in this condition (refer to [Section 2.4.3.](#)). The Status Utility screen can be used to verify the levels of the STO input signals while trouble shooting.

In order to meet the listed SIL level, the STO circuit must be activated (power removed from both inputs) according to the interval specified in [Table 2-27.](#)

Table 2-30: STO Timing

Time	Description	Value
T1	STO Delay Time (STO input active to motor power off)	450-550 msec
T2	STO deactivated to motor power on (the software is typically configured so that the motor does not automatically re-energize).	< 1 msec
T3	Diagnostic Test Delay Time	550-610 msec

Figure 2-28: STO Timing

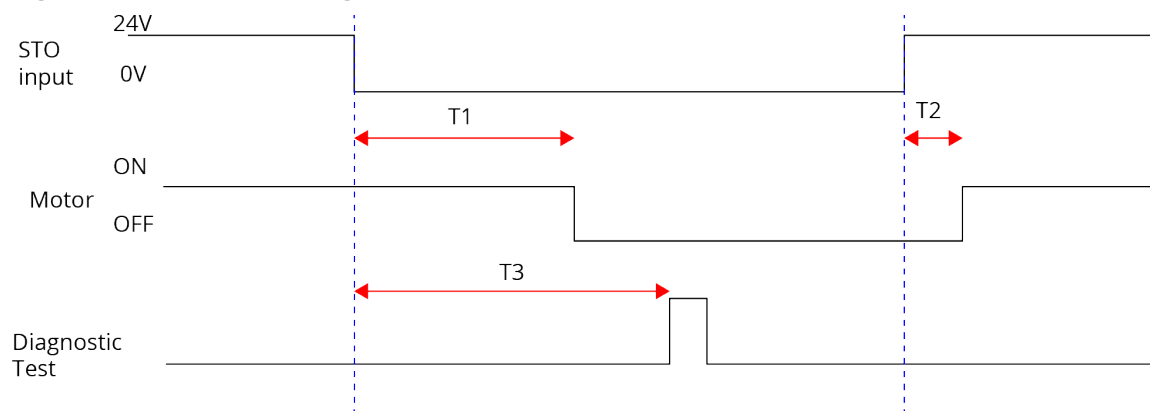

The software is typically configured to execute a controlled stop when the STO state is first detected. If power is reapplied to the STO inputs before the STO Delay Time, an STO hardware shutdown will not occur but a software stop may, depending on the width of the STO pulse. The controller will ignore STO active pulses shorter in length than the STOPulseFilter parameter setting.

2.5. HyperWire Interface

The HyperWire bus is the high-speed communications connection from the controller. It operates at 2 gigabits per second. The controller sends all command and configuration information through the HyperWire bus.

HyperWire cables can be safely connected to or disconnected from a HyperWire port while the PC and/or drive is powered on. However, any changes to the HyperWire network topology will disrupt communication and you must reset the controller to re-establish communication.



WARNING: Do not connect or disconnect HyperWire cables while you are loading firmware or damage to the drives may occur.

Table 2-31: HyperWire Card Part Number

Part Number	Description
HYPERWIRE-PCIE	HyperWire adapter, PCIe x4 interface

Table 2-32: HyperWire Cable Part Numbers

Part Number	Description
HYPERWIRE-AO10-5	HyperWire cable, active optical, 0.5 m
HYPERWIRE-AO10-10	HyperWire cable, active optical, 1.0 m
HYPERWIRE-AO10-30	HyperWire cable, active optical, 3.0 m
HYPERWIRE-AO10-50	HyperWire cable, active optical, 5.0 m
HYPERWIRE-AO10-200	HyperWire cable, active optical, 20.0 m

2.6. System Interconnection

Figure 2-29: Drive-Based System Wiring Drawing (Best Practice)

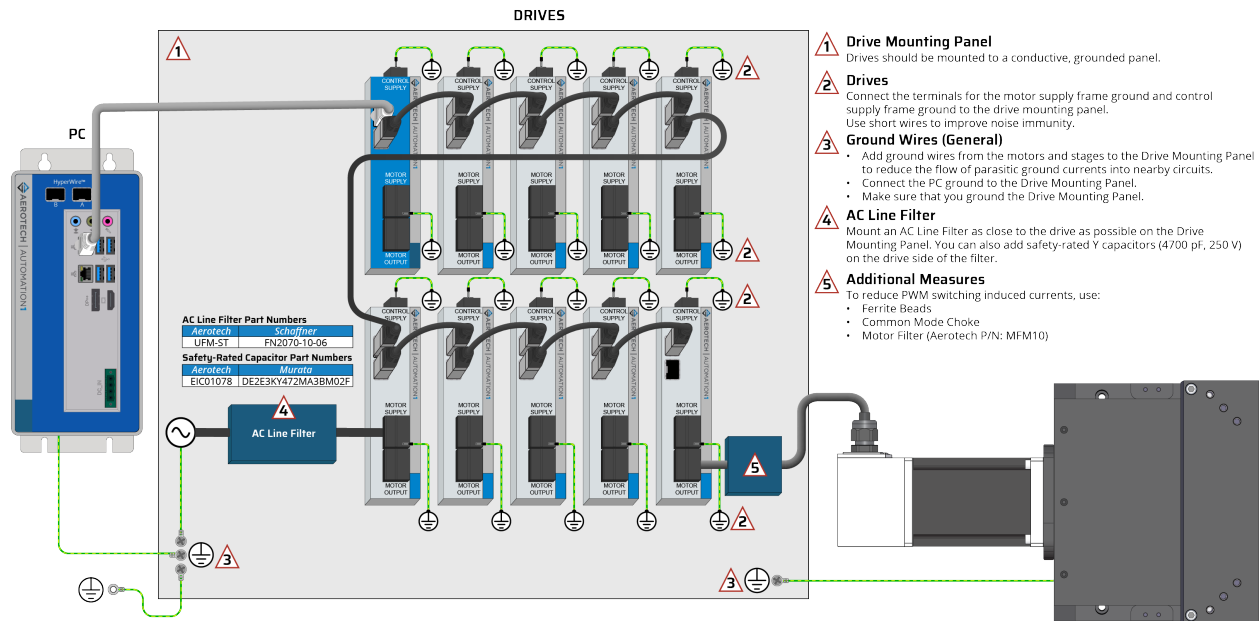

Figure 2-30: PC-Based System Wiring Drawing (Best Practice)

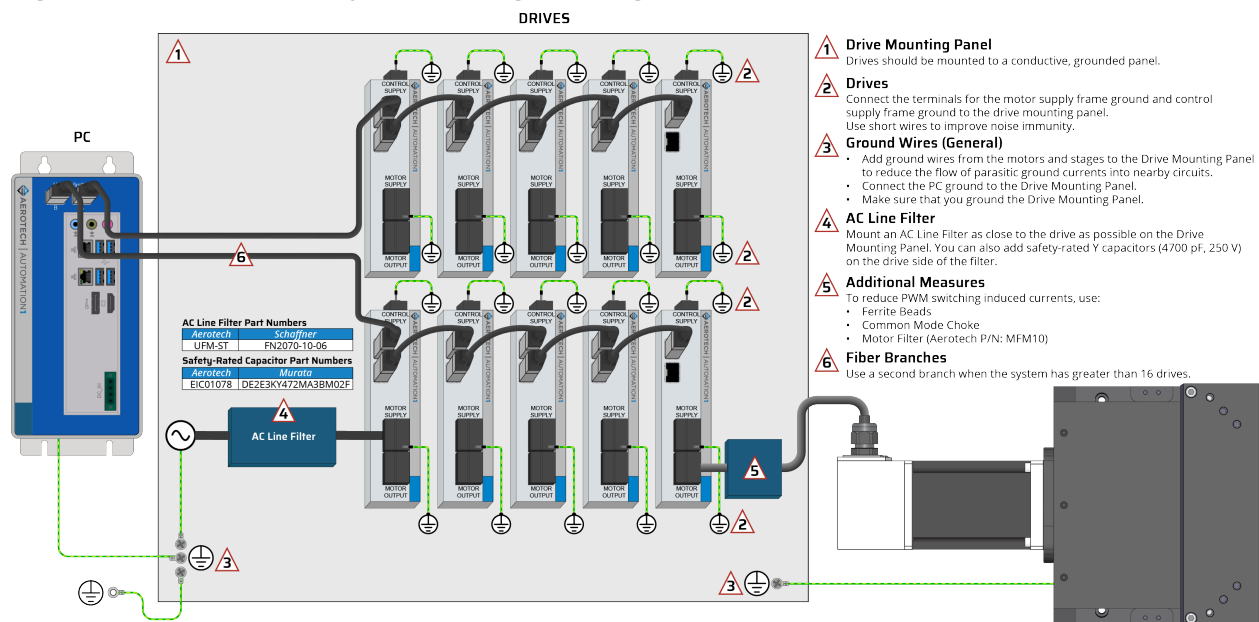
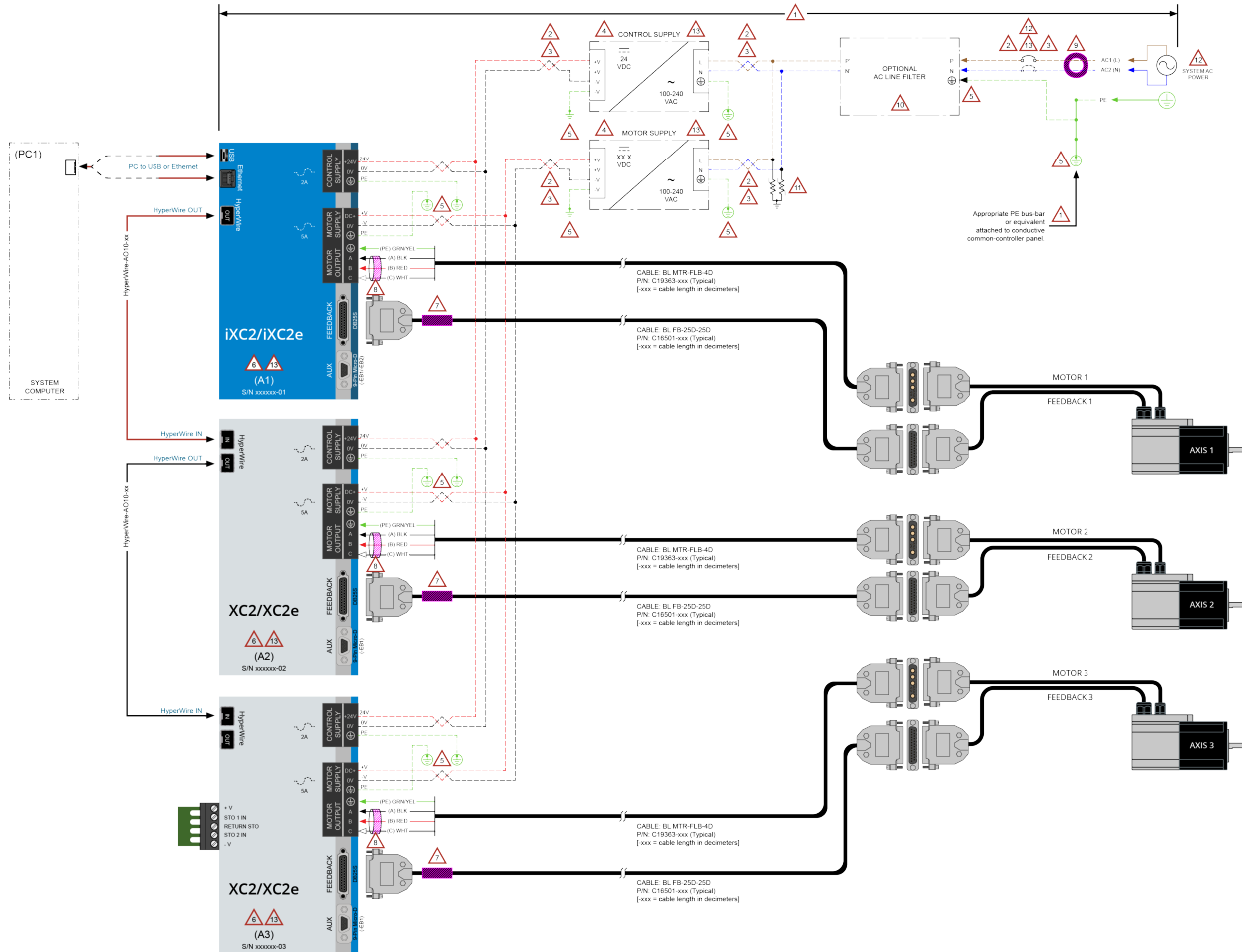
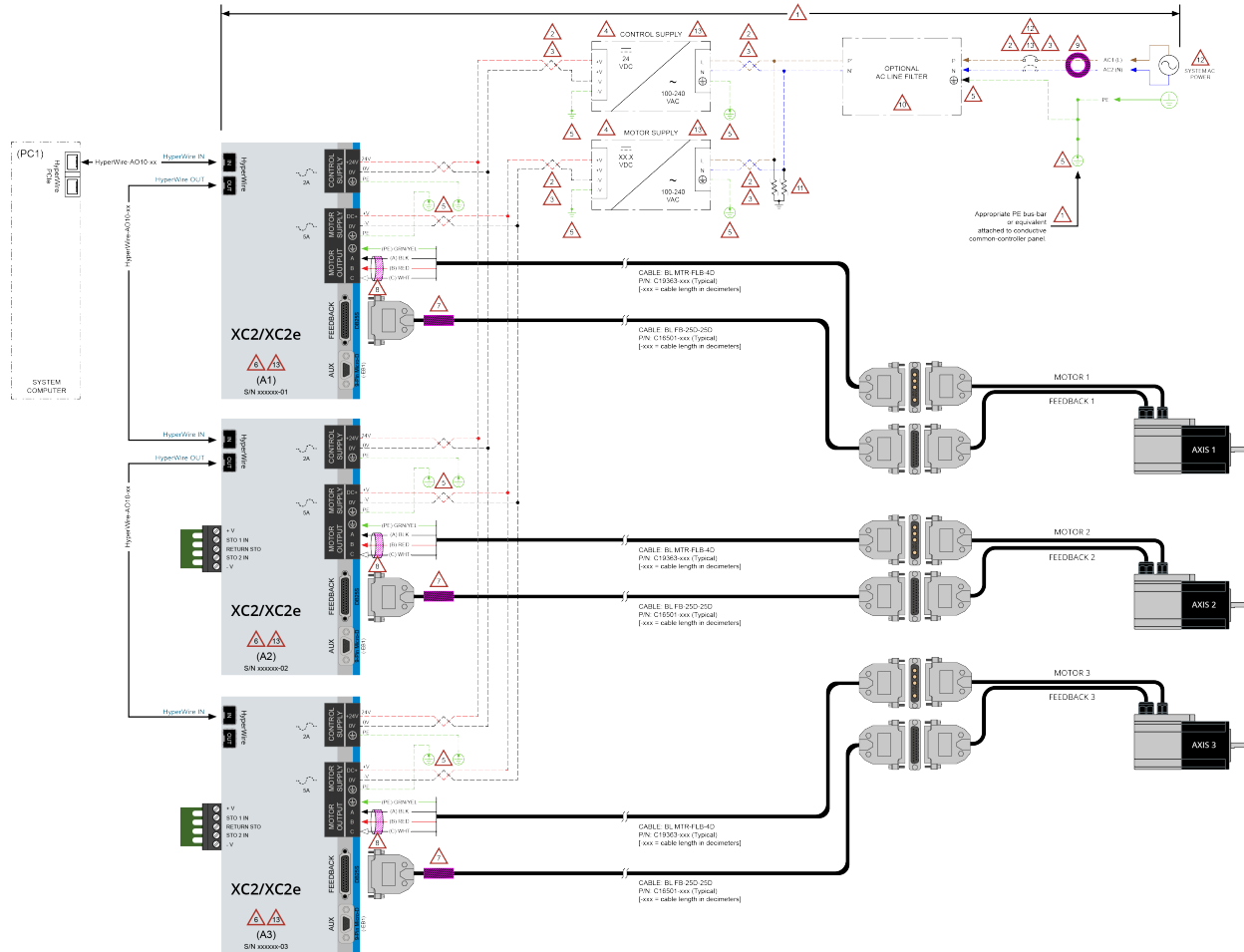

Figure 2-31: Drive-Based Controller System Interconnection (Best Practice)



<p>! ATTENTION !</p> <p>The system integrator or end user is responsible for all safety compliance and technical requirements for the system wiring.</p> <p>IMPORTANT: Read all parts of this manual before you install or operate the drive or before you do maintenance to your system.</p> <p>*To prevent injury to you and damage to the equipment, obey the precautions in this manual.</p> <p>*If you do not understand the information in this manual, contact Aerotech Global Technical Support.</p> <p>For EMC performance, mount all system components on to a common conductive metal panel.</p> <ul style="list-style-type: none"> Do not use a panel that has a painted or non-conductive coat applied. You can use a panel with a conductive surface coat. <p>System Wiring ROUTING</p> <ul style="list-style-type: none"> Separate VAD and VDC wires Separate Motor Supply from Control Supply, Low-Voltage I/O, and Control and Feedback signal wires Separate motor and cable wiring from Control Supply, Low-Voltage I/O, and Control and Feedback signal wires, and VAD/VDC supply wires. <p>System Wiring SPECIFICATIONS</p> <ul style="list-style-type: none"> Aerotech recommends that you use twisted pair conductors with wire lengths as short as possible. Wire Size: <ul style="list-style-type: none"> - AC POWER: 1.3 mm² [16 AWG] - MOTOR POWER: 3.0 mm² [20 AWG] - CONTROL POWER: 0.34 mm² [22 AWG] 	<p>System Wiring SPECIFICATIONS (continued)</p> <ul style="list-style-type: none"> Wire Conformity: <ul style="list-style-type: none"> - North America: UL AWM - EU: -HARV-0C <p>System Control and Motor VDC Power Supplies</p> <ul style="list-style-type: none"> Minimum Requirements: <ul style="list-style-type: none"> - Pollution Degree 2 - Double insulated - Short-circuit and over-voltage protection - UL and CE approvals Recommended Power Supplies * <ul style="list-style-type: none"> - 24 VDC Control Supply <ul style="list-style-type: none"> Mean Well P/N: NDR-75-24 (DIN Rail power supply, 75W 24V 3.2A) - 48 VDC Motor Supply <ul style="list-style-type: none"> Mean Well P/N: NDR-480-48 (DIN Rail power supply, 480W 48V 10A) - 24 VDC Motor Supply <ul style="list-style-type: none"> Mean Well P/N: NDR-240-24 (DIN Rail power supply, 240W 24V 10A) * Refer to the Mean Well "NDR" Series Installation Manual! <p>System Protective Earth (PE) grounds</p> <ul style="list-style-type: none"> Keep PE wires as short as possible. Each PE wire must have a dedicated attachment point. Terminate each PE directly to the grounded component panel (and that the component panel conform to NOTE 1). <p>iXC2e/XC2e and XC2e/XC2e Drives</p> <ul style="list-style-type: none"> Refer to assemblies (A1), (A2), and (A3) If the controllers were purchased as an integrated system, refer to the System Interconnections drawing included with the system documentation. 	<p>Axis Feedback Cable Ferrite EMC Filters</p> <ul style="list-style-type: none"> Use Aerotech P/N: EC22248 (Fair-Rite P/N: 6446167281, Clamp On filters) Attach the filter near to the feedback connector back-shield as illustrated. <p>Axis Motor Cable Ferrite EMC Filters</p> <ul style="list-style-type: none"> Use Aerotech P/N: EC220367 (Fair-Rite P/N: 2631626402) ferrite cores on motor-phase leads A, B, and C. Attach the filter near to the controller's motor output terminals. <p>AC Power Source EMC Filter (RECOMMENDED)</p> <ul style="list-style-type: none"> Not required for EMC compliance. Use Aerotech P/N: EC220398 (Fair-Rite P/N: ALFB300230-300) Forwarding construction. Loop system AC1 and AC2 conductor pair two times tightly through the toroid. <p>System AC Power EMC Filter (RECOMMENDED)</p> <ul style="list-style-type: none"> A filter is NOT required for EMC "Conducted Emissions" compliance. A filter IS required for EMC "Surge Immunity" compliance. Use Aerotech P/N: EC220204 (Schaffner P/N: FQ200-10-06) or equivalent. <p>Metal Oxide Varistor (MOV) (RECOMMENDED)</p> <ul style="list-style-type: none"> Required for EMC "Surge Immunity" compliance. Install (1) MOV to each AC1 and AC2 line as shown. Use Aerotech P/N: EDD00197 (Littelfuse P/N: V20E385P) or equivalent. <p>System AC Power</p> <ul style="list-style-type: none"> The system AC power must have a fuse or circuit breaker protection. Voltages and currents are dependent on the selected power supplies and system axis requirements (refer to NOTE 4). <p>DIN-Rail Mounted Components</p> <ul style="list-style-type: none"> Use DIN Rail from Phoenix P/N: NS 30/7.5 PERF 200DMM - 0801733 or equivalent. <p>The information on this page is for reference only and represents best practice applications.</p>
--------------------------------------------------------------------------------------------------------------------------------------------------------------------------------------------------------------------------------------------------------------------------------------------------------------------------------------------------------------------------------------------------------------------------------------------------------------------------------------------------------------------------------------------------------------------------------------------------------------------------------------------------------------------------------------------------------------------------------------------------------------------------------------------------------------------------------------------------------------------------------------------------------------------------------------------------------------------------------------------------------------------------------------------------------------------------------------------------------------------------------------------------------------------------------------------------------------------------------------------------------------------------------------------------------------------------------------------------------------------------------------------------------------------------------------------------------------------------------------------------------------------------------------------------------------------------------------------------------------------------------	--------------------------------------------------------------------------------------------------------------------------------------------------------------------------------------------------------------------------------------------------------------------------------------------------------------------------------------------------------------------------------------------------------------------------------------------------------------------------------------------------------------------------------------------------------------------------------------------------------------------------------------------------------------------------------------------------------------------------------------------------------------------------------------------------------------------------------------------------------------------------------------------------------------------------------------------------------------------------------------------------------------------------------------------------------------------------------------------------------------------------------------------------------------------------------------------------------------------------------------------------------------------------------------------------------------------------------------------------------------------------------------------------------------------------------------------------------------------------------------------------------------------------------------------------------------------------------------------------------------------------------------------------------------------------------------------------------------------------------------------------------------------------------------------------------------------------------------------------------------------------------------------------	----------------------------------------------------------------------------------------------------------------------------------------------------------------------------------------------------------------------------------------------------------------------------------------------------------------------------------------------------------------------------------------------------------------------------------------------------------------------------------------------------------------------------------------------------------------------------------------------------------------------------------------------------------------------------------------------------------------------------------------------------------------------------------------------------------------------------------------------------------------------------------------------------------------------------------------------------------------------------------------------------------------------------------------------------------------------------------------------------------------------------------------------------------------------------------------------------------------------------------------------------------------------------------------------------------------------------------------------------------------------------------------------------------------------------------------------------------------------------------------------------------------------------------------------------------------------------------------------------------------------------------------------------------------------------------------------------------------------------------------------------------------------------------------------------------------------------------------------------------------------------------------------------------------------------------------------------------------------------------------------------------------------------------------------------------------------------------------------------

Figure 2-32: PC-Based Controller System Interconnection (Best Practice)



<p>! ATTENTION !</p> <p>The system integrator or end user is responsible for all safety compliance and technical requirements for the system wiring.</p> <p>IMPORTANT: Read all parts of this manual before you install or operate the drives or before you do maintenance to your system.</p> <p>*To prevent injury to you and damage to the equipment, obey the precautions in this manual.</p> <p>*If you do not understand the information in this manual, contact Aerotech Global Technical Support.</p> <p>For EMC performance, mount all system components on a common conductive metal panel.</p> <ul style="list-style-type: none"> Do not use a panel that has a painted or non-conductive coat applied. You can use a panel with a conductive surface coat. <p>System Wiring ROUTING</p> <ul style="list-style-type: none"> Separate VAC and VDC wires Separate Motor Supply, Low-Voltage I/O, and Control and Feedback signal wires Separate motor and cable wiring from Control Supply, Low-Voltage I/O, and Control and Feedback signal wires, and VAC/VDC supply wires. <p>System Wiring SPECIFICATIONS</p> <ul style="list-style-type: none"> Aerotech recommends that you use twisted pair conductors with wire lengths as short as possible. Wire Size: <ul style="list-style-type: none"> - AC POWER: 1.3 mm² [16 AWG] - MOTOR POWER: 3.0 mm² [20 AWG] - CONTROL POWER: 0.34 mm² [22 AWG] 	<p>System Wiring SPECIFICATIONS (continued)</p> <ul style="list-style-type: none"> Wire Conformity: <ul style="list-style-type: none"> - North America: UL AWM - EU: -HARV-0C <p>System Control and Motor VDC Power Supplies</p> <ul style="list-style-type: none"> Minimum Requirements: <ul style="list-style-type: none"> - Pollution Degree 2 - Double insulated - Short-circuit and over-voltage protection - UL and CE approvals Recommended Power Supplies * <ul style="list-style-type: none"> - 24 VDC Control Supply <ul style="list-style-type: none"> Mean Well P/N: NDR-75-24 (DIN Rail power supply, 75W 24V 3.2A) - 48 VDC Motor Supply <ul style="list-style-type: none"> Mean Well P/N: NDR-480-48 (DIN Rail power supply, 480W 48V 10A) - 24 VDC Motor Supply <ul style="list-style-type: none"> Mean Well P/N: NDR-240-24 (DIN Rail power supply, 240W 24V 10A) * Refer to the Mean Well "NDR" Series Installation Manual! <p>System Protective Earth (PE) grounds</p> <ul style="list-style-type: none"> Keep PE wires as short as possible Each PE wire must have a dedicated attachment point Terminate each PE directly to the grounded component panel (and that the component panel conform to NOTE 1). <p>XC2e/XC2e Controllers</p> <ul style="list-style-type: none"> Refer to assemblies (A1), (A2), and (A3) If the controllers were purchased as an integrated system, refer to the System Interconnections drawing included with the system documentation. 	<p>Axis Feedback Cable Ferrite EMC Filters</p> <ul style="list-style-type: none"> Use Aerotech P/N: EC220248 (Fair-Rite P/N: 6446167281). Clamp On filters Attach the filter near to the feedback connector back-shield as illustrated <p>Axis Motor Cable Ferrite EMC Filters</p> <ul style="list-style-type: none"> Use Aerotech P/N: EC220287 (Fair-Rite P/N: 2631626402) ferrite cores on motor-phase leads A, B, and C. Attach the filter near to the controller's motor output terminals <p>AC Power Source EMC Filter (RECOMMENDED)</p> <ul style="list-style-type: none"> Not required for EMC compliance Use Aerotech P/N: EC220298 (Fair-Rite P/N: ALFB300230-300) Forwarding construction <ul style="list-style-type: none"> - Loop system AC1 and AC2 conductor pair two times tightly through the toroid <p>System AC Power EMC Filter (RECOMMENDED)</p> <ul style="list-style-type: none"> A filter is NOT required for EMC "Conducted Emissions" compliance A filter IS required for EMC "Surge Immunity" compliance Use Aerotech P/N: EC220294 (Schaffner P/N: FZ070-10-06) or equivalent <p>Metal Oxide Varistor (MOV) (RECOMMENDED)</p> <ul style="list-style-type: none"> Required for EMC "Surge Immunity" compliance Install 1x MOV to each AC1 and AC2 line as shown Use Aerotech P/N: EDD00197 (Littelfuse P/N: V20E385P) or equivalent <p>System AC Power</p> <ul style="list-style-type: none"> The system AC power must have a fuse or circuit breaker protection Voltages and currents are dependent on the selected power supplies and system axis requirements (refer to NOTE 4). <p>DIN-Rail Mounted Components</p> <ul style="list-style-type: none"> Use DIN Rail from Phoenix P/N: NS 35/ 7.5 PERF 2000MM - 0801733 or equivalent <p>The information on this page is for reference only and represents best practice applications.</p>
----------------------------------------------------------------------------------------------------------------------------------------------------------------------------------------------------------------------------------------------------------------------------------------------------------------------------------------------------------------------------------------------------------------------------------------------------------------------------------------------------------------------------------------------------------------------------------------------------------------------------------------------------------------------------------------------------------------------------------------------------------------------------------------------------------------------------------------------------------------------------------------------------------------------------------------------------------------------------------------------------------------------------------------------------------------------------------------------------------------------------------------------------------------------------------------------------------------------------------------------------------------------------------------------------------------------------------------------------------------------------------------------------------------------------------------------------------------------------------------------------------------------------------------------------------------------------------------------------------	--------------------------------------------------------------------------------------------------------------------------------------------------------------------------------------------------------------------------------------------------------------------------------------------------------------------------------------------------------------------------------------------------------------------------------------------------------------------------------------------------------------------------------------------------------------------------------------------------------------------------------------------------------------------------------------------------------------------------------------------------------------------------------------------------------------------------------------------------------------------------------------------------------------------------------------------------------------------------------------------------------------------------------------------------------------------------------------------------------------------------------------------------------------------------------------------------------------------------------------------------------------------------------------------------------------------------------------------------------------------------------------------------------------------------------------------------------------------------------------------------------------------------------------------------------------------------------------------------------------------------------------------------------------------------------------------------------------------------------------------------------------------------------------------------------------------------------------------------------------------------------------	------------------------------------------------------------------------------------------------------------------------------------------------------------------------------------------------------------------------------------------------------------------------------------------------------------------------------------------------------------------------------------------------------------------------------------------------------------------------------------------------------------------------------------------------------------------------------------------------------------------------------------------------------------------------------------------------------------------------------------------------------------------------------------------------------------------------------------------------------------------------------------------------------------------------------------------------------------------------------------------------------------------------------------------------------------------------------------------------------------------------------------------------------------------------------------------------------------------------------------------------------------------------------------------------------------------------------------------------------------------------------------------------------------------------------------------------------------------------------------------------------------------------------------------------------------------------------------------------------------------------------------------------------------------------------------------------------------------------------------------------------------------------------------------------------------------------------------------------------------------------------------------------------------------------------------------------------------------------------------------------------------------------------------------------------------------------------------------------------------------------------------------------

2.7. PC Configuration and Operation Information

For more information about hardware requirements, PC configuration, programming, system operation, and utilities, refer to the [Help file](#).

This page intentionally left blank.

Chapter 3: -EB1/-EB2 Option Expansion Board

The -EB1 option board has an auxiliary encoder, 8 digital inputs, 8 digital outputs, 1 analog input, 1 analog output, and PSO outputs.

The -EB2 option board is only available on the iXC2e. It has an auxiliary encoder, PSO Outputs and two Industrial Ethernet ports (not shown).

Figure 3-1: Expansion Option Board Connectors (iXC2e shown)

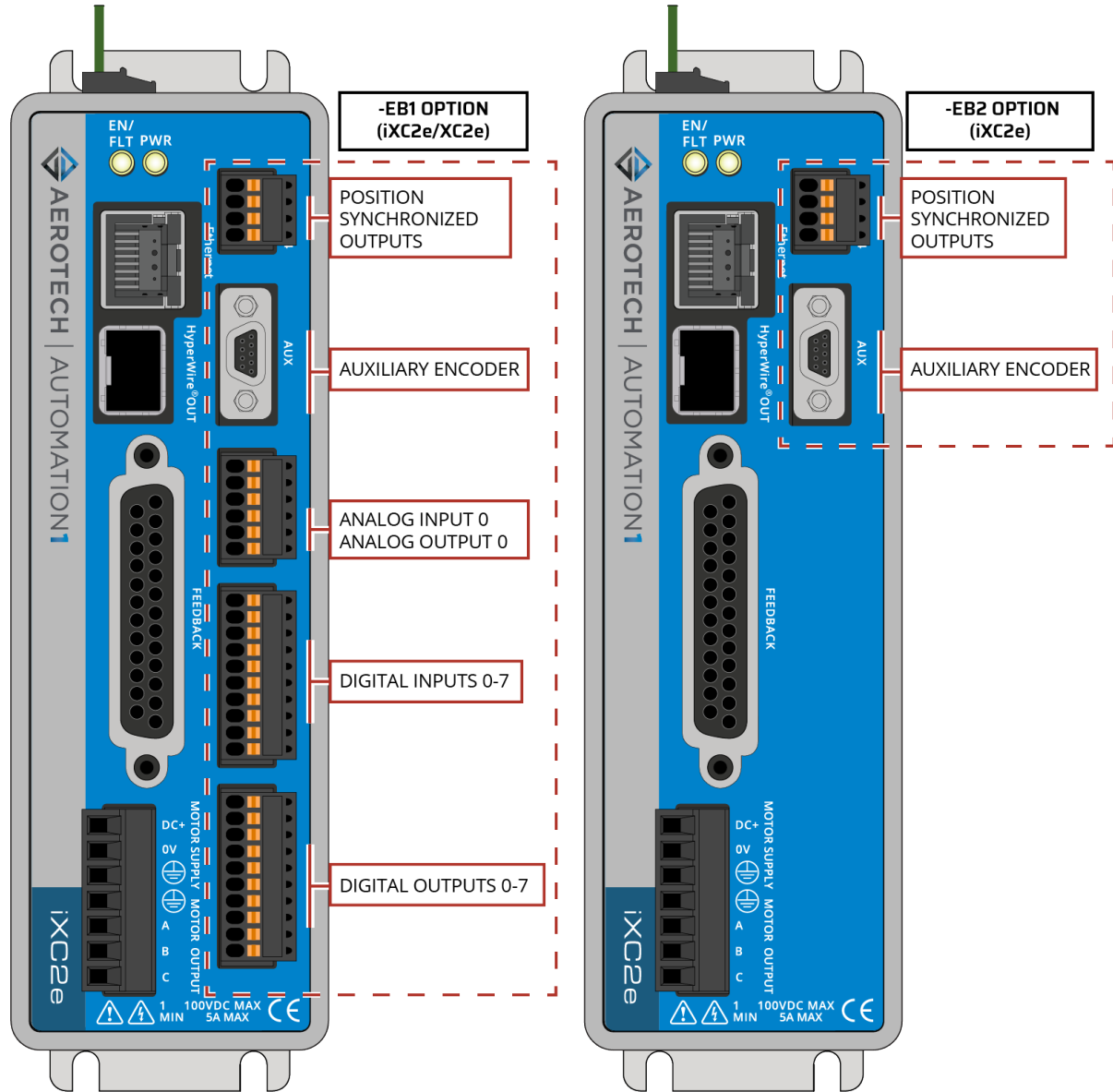

3.1. PSO Interface [-EB1/-EB2]

The Position Synchronized Output (PSO) signal is available on the -EB1 and -EB2 option board in two signal formats: TTL and Isolated.

Table 3-1: PSO Specifications [-EB1/-EB2]

Specification		Value
Output	TTL	5 V, 50 mA (max)
	Isolated	5-24 V, 250 mA
Maximum PSO Output (Fire) Frequency	TTL	12.5 MHz
	Isolated	5 MHz
Output Latency [Fire event to output change]	TTL	5 ns
	Isolated	150 ns

Table 3-2: PSO Interface Connector Pinout [-EB1/-EB2]

Pin #	Description	In/Out/Bi	Connector
1	PSO Output+	Output	
2	PSO Output-	Output	
3	PSO Output (TTL)	Output	
4	Ground	N/A	

Table 3-3: PSO Interface Mating Connector Ratings [-EB1/-EB2]

Specification		Description
Type		4-Pin Terminal Block
Part Numbers		Aerotech: ECK02399
		Phoenix: 1768004
Conductor Cross Section	Solid or stranded	20...26 AWG (0.14...0.5 mm ²)
	Stranded, with ferrule, without plastic sleeve	20...24 AWG (0.25...0.5 mm ²)
Conductor Insulation Strip Length		8 mm (5/16 in)
(1) Refer to the manufacturer website for additional information.		

Isolated Signals

This output signal is a fully-isolated 5-24V compatible output capable of sourcing or sinking current. This output is normally open and only conducts current when a PSO fire event occurs. The PSO Isolated Outputs are overload protected and will turn off if the maximum output current is exceeded.

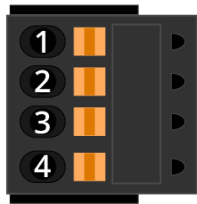
Figure 3-2: PSO Output Sources Current

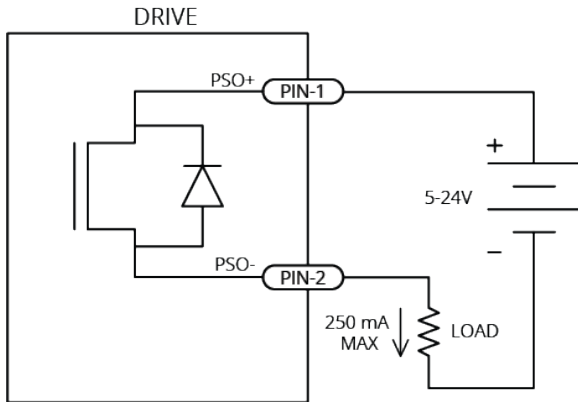
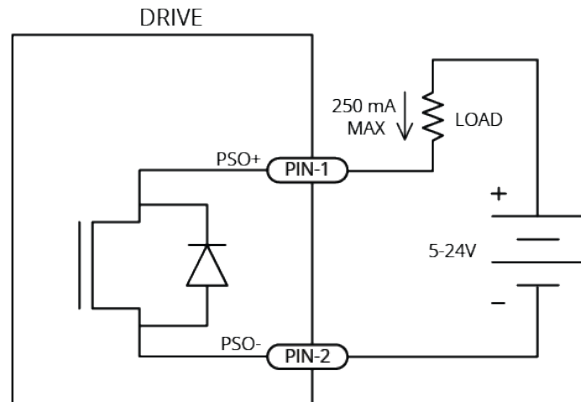

Figure 3-3: PSO Output Sinks Current



TTL Signals

This output signal is a 5V TTL signal which is used to drive an opto coupler or general purpose TTL input. This signal is active high and is driven to 5V when a PSO fire event occurs.

Figure 3-4: PSO TTL Outputs Schematic

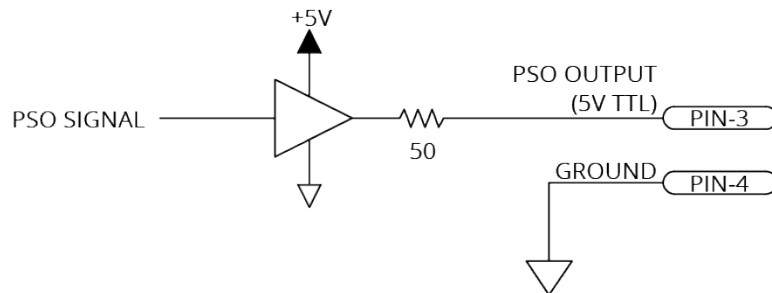

3.2. Auxiliary Encoder Interface [-EB1/-EB2]

The Auxiliary Encoder connector gives you a second encoder channel. This channel is typically used for dual loop applications.

Use the AuxiliaryFeedbackType parameter to configure the drive to accept an encoder signal type.

Square Wave encoder signals: [Section 3.2.1.](#)

Absolute encoder signals: [Section 3.2.2.](#)

Sine Wave encoder signals (with the -MX3 option): [Section 3.2.3.](#)

You can configure the Auxiliary Encoder interface as an output that will transmit encoder signals for external use. Use the DriveEncoderOutputConfigureInput() function to configure the Sine ± and Cosine ± connector pins as RS-422 outputs. You can only echo incremental square wave primary encoder inputs or, with the with the -MX2 or -MX3 option, incremental sine wave primary encoder inputs.

Table 3-4: Auxiliary Encoder Connector Pinout

Pin#	Description	In/Out/Bi	Connector
1	Auxiliary Marker -	Input	
2	Auxiliary Cosine+	Bidirectional	
	Absolute Encoder Clock +	Output	
3	Auxiliary Cosine-	Bidirectional	
	Absolute Encoder Clock -	Output	
4	Auxiliary Sine+	Bidirectional	
	Absolute Encoder Data +	Bidirectional	
5	Encoder Cable Shield	N/A	
6	Auxiliary Marker +	Input	
7	+5 Volt (500 mA max)	Output	
8	Signal Common	Output	
9	Auxiliary Sine-	Bidirectional	
	Absolute Encoder Data -	Bidirectional	

Table 3-5: AUX Mating Connector Ratings

Adapter Cable	Aerotech P/N	Third Party P/N
9-Pin Standard D-style	C20931	N/A
25-Pin Standard D-style	C20932	N/A
Flying Leads	ECZ01343	Molex 83421-9042
9-Pin Micro D-Style (for a second Auxiliary Encoder Input)	ECZ03125	N/A

3.2.1. Square Wave Encoder (Auxiliary)

The drive accepts RS-422 square wave encoder signals. The drive will generate a feedback fault if it detects an invalid signal state caused by an open or shorted signal connection. Use twisted-pair wiring for the highest performance and noise immunity.

Table 3-6: Square Wave Encoder Specifications

Specification	Value
Encoder Frequency	10 MHz maximum (25 ns minimum edge separation)
x4 Quadrature Decoding	40 million counts/sec

Figure 3-5: Square Wave Encoder Interface (Aux Connector)

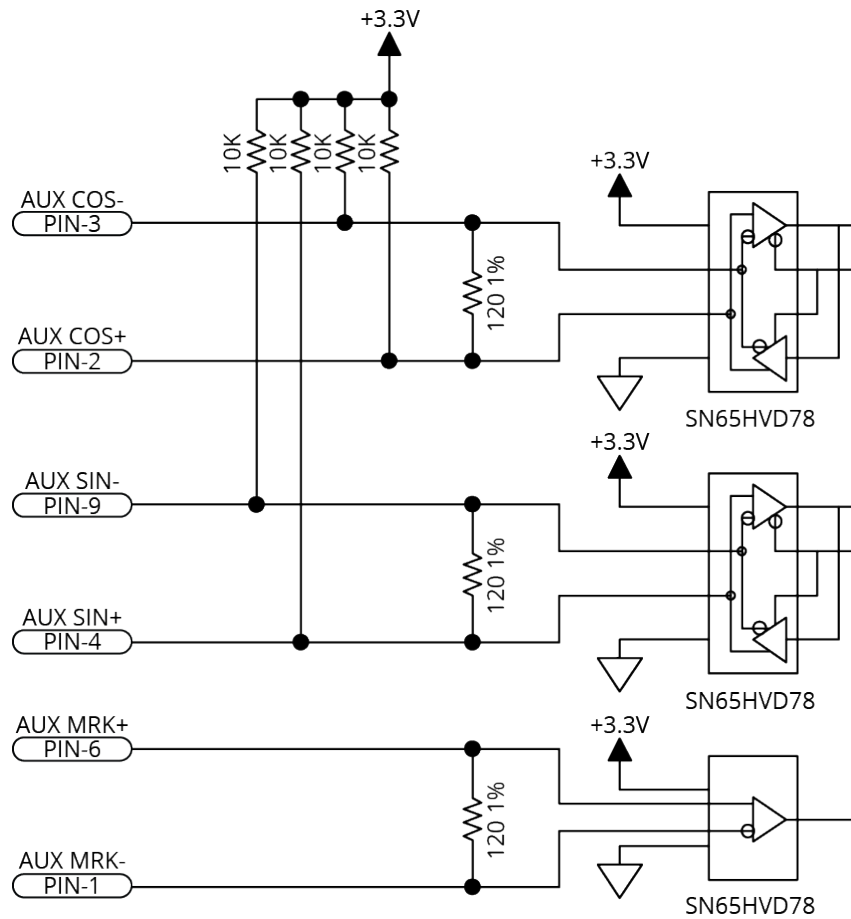

3.2.2. Absolute Encoder (Auxiliary)

The drive retrieves absolute position data along with encoder fault information through a serial data stream from the absolute encoder. Use twisted-pair wiring for the highest performance and noise immunity. You cannot use an absolute encoder with incremental signals on the Auxiliary Encoder Connector.

Refer to [Figure 3-6](#) for the serial data stream interface.

Refer to the [Help file](#) for information on how to set up your EnDat or BiSS absolute encoder parameters.

Figure 3-6: Absolute Encoder Schematic (Auxiliary Encoder Connector)

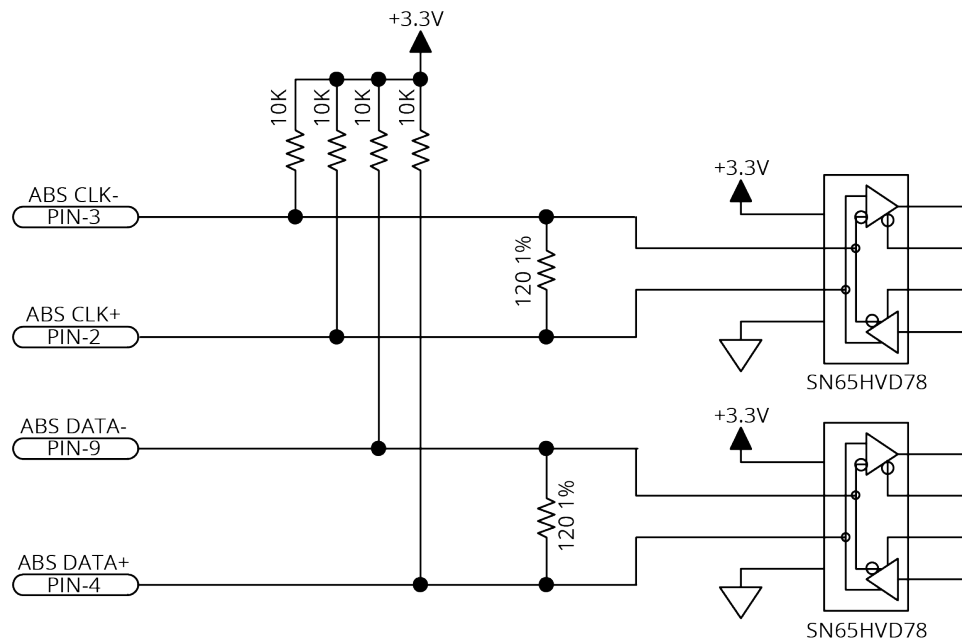

3.2.3. Sine Wave Encoder (Auxiliary) [-MX3 Option]

The Sine Wave Encoder option provides higher positioning resolution by subdividing the fundamental output period of the encoder into smaller increments. The amount of subdivision is specified by the AuxiliaryEncoderMultiplicationFactor parameter. Use Encoder Tuning to adjust the value of the gain, offset, and phase balance controller parameters to get the best performance. For more information, refer to the [Help file](#).

You cannot use the sine wave encoder on the auxiliary connector with the -MX3 multiplier option as an input to the PSO. The -MX3 option does not generate emulated quadrature signals from the auxiliary connector.

For the highest performance, use twisted pair double-shielded cable with the inner shield connected to signal common and the outer shield connected to frame ground. Do not join the inner and outer shields in the cable.

Table 3-7: Sine Wave Encoder Specifications

Specification	Value	
	Primary	Auxiliary
Input Frequency (max)	200 kHz, 2 MHz	200 kHz
Input Amplitude ⁽¹⁾	0.6 to 1.75 Vpk-pk	
Interpolation Factor (max)	-MX2	65,536
	-MX3	65,536
-MX2/-MX3 Primary Encoder Channel Interpolation Latency	800 nsec (analog input to quadrature output)	
Input Common Mode	1.5 to 3.5 VDC	

(1) Measured as SIN(+) - SIN(-) or COS(+) - COS(-)

Figure 3-7: Sine Wave Encoder Phasing Reference Diagram

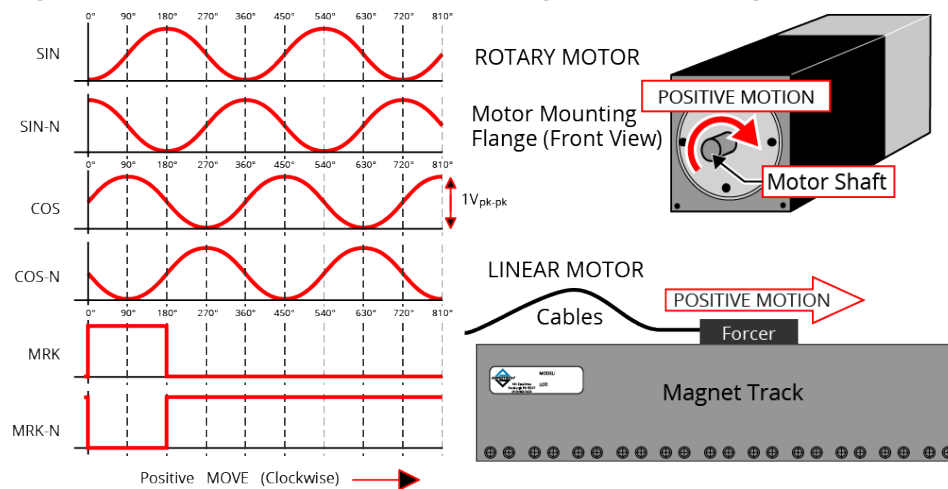
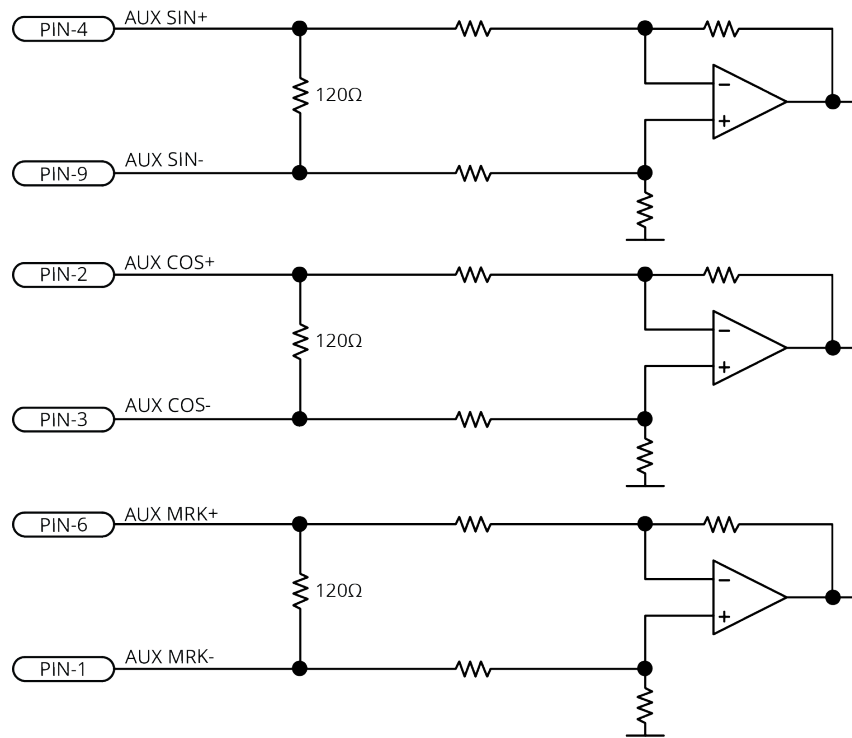

Figure 3-8: Sine Wave Encoder Schematic (Aux Connector)

3.3. Analog I/O [-EB1]

The Analog I/O connector has one differential analog input and one analog output.

Table 3-8: Analog I/O Connector Pinout [-EB1]

Pin#	Description	In/Out/Bi	Connector
1	+5 V (250 mA max)	Output	
2	Analog Input 0+	Input	
3	Analog Input 0-	Input	
4	Ground	N/A	
5	Ground	N/A	
6	Analog Output 0	Output	

Table 3-9: Analog I/O Mating Connector Ratings [-EB1]

Specification		Description
Type		6-Pin Terminal Block
Part Numbers		Aerotech: ECK02405 Phoenix: 1704755
Conductor Cross Section	Solid or stranded	20...26 AWG (0.14...0.5 mm ²)
	Stranded, with ferrule, without plastic sleeve	20...24 AWG (0.25...0.5 mm ²)
Conductor Insulation Strip Length		8 mm (5/16 in)
(1) Refer to the manufacturer website for additional information.		

3.3.1. Analog Output 0 [-EB1]

The analog output can be set from within a program or it can be configured to echo the state of select servo loop nodes.

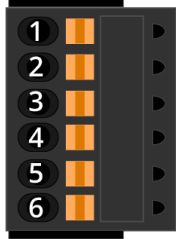
The analog output is set to zero when you power on the system or reset the drive.

Table 3-10: Analog Output Specifications [-EB1]

Specification	Value
Output Voltage	-10 V to +10 V
Output Current	5 mA
Resolution (bits)	16 bits

Table 3-11: Analog Output Pins on the Analog I/O Connector [-EB1]

Pin#	Description	In/Out/Bi
5	Ground	N/A
6	Analog Output 0	Output

Figure 3-9: Analog Output Schematic [-EB1]

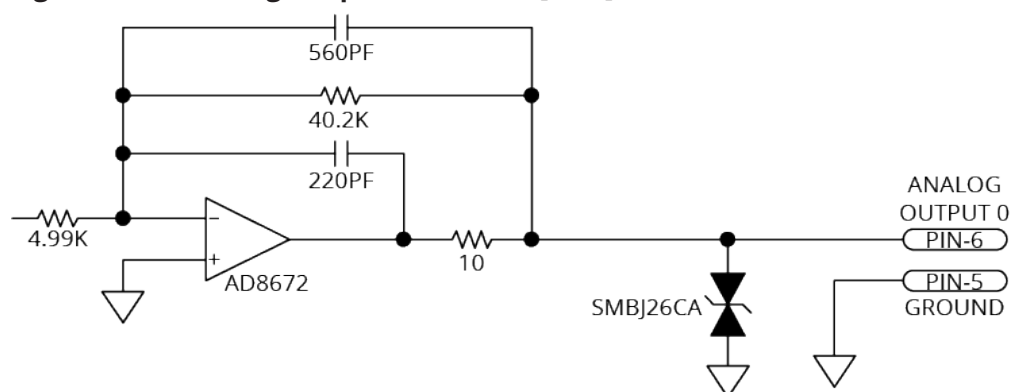

3.3.2. Analog Input (Differential) [-EB1]

To interface to a single-ended, non-differential voltage source, connect the signal common of the source to the negative input and connect the analog source signal to the positive input. A floating signal source must be referenced to the analog common. Refer to Figure 3-10.

Table 3-12: Differential Analog Input Specifications [-EB1]

Specification	Value
(AI+) - (AI-)	+10 V to -10 V ⁽¹⁾
Resolution (bits)	16 bits
Input Impedance	1 MΩ
1. Signals outside of this range may damage the input	

Table 3-13: Analog Input Pins on the Analog I/O Connector [-EB1]

Pin#	Description	In/Out/Bi
1	+5 V (250 mA max)	Output
2	Analog Input 0+	Input
3	Analog Input 0-	Input
4	Ground	N/A

Figure 3-10: Analog Input Schematic [-EB1]

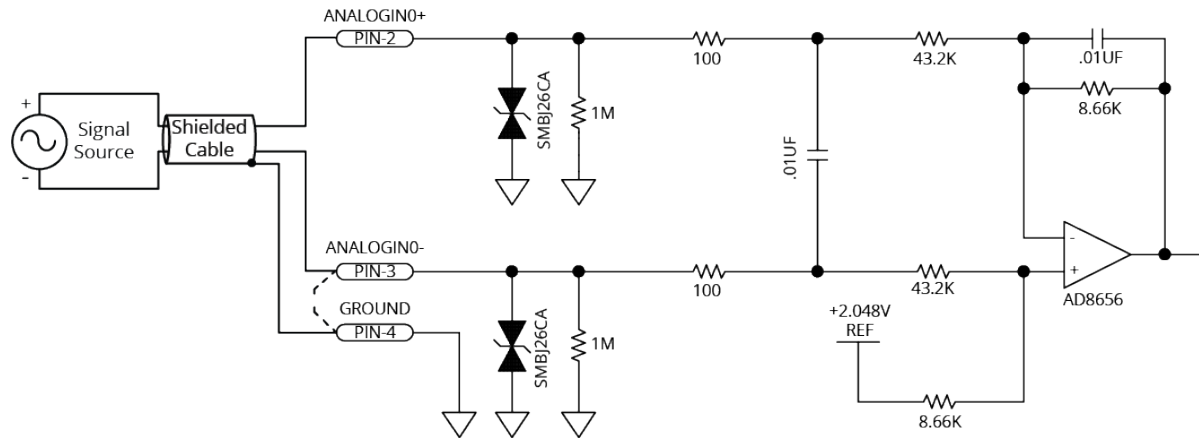

3.4. Digital Outputs [-EB1]

Optically-isolated solid-state relays drive the digital outputs. You can connect the digital outputs in current sourcing or current sinking mode but you must connect all four outputs in a port in the same configuration. Refer to [Figure 3-12](#) and [Figure 3-13](#).

The digital outputs are not designed for high-voltage isolation applications and they should only be used with ground-referenced circuits.

You must install suppression diodes on digital outputs that drive relays or other inductive devices. To see an example of a current sourcing output that has diode suppression, refer to [Figure 3-12](#). To see an example of a current sinking output that has diode suppression, refer to [Figure 3-13](#).

The digital outputs have overload protection. They will resume normal operation when the overload is removed.

Table 3-14: Digital Output Specifications [-EB1]

Digital Output Specifications	Value
Maximum Voltage	24 V (26 V Maximum)
Maximum Sink/Source Current	250 mA/output
Output Saturation Voltage	0.9 V at maximum current
Output Resistance	3.7 Ω
Rise / Fall Time	250 μ s (2K pull up to 24V)
Reset State	Output Off (High Impedance State)

Table 3-15: Digital Output Connector Pinout [-EB1]

Pin#	Description	In/Out/Bi	Connector
1	Output Common for Outputs 0-3	Output	
2	Output 0 (Optically-Isolated)	Output	
3	Output 1 (Optically-Isolated)	Output	
4	Output 2 (Optically-Isolated)	Output	
5	Output 3 (Optically-Isolated)	Output	
6	Output Common for Outputs 4-7	Output	
7	Output 4 (Optically-Isolated)	Output	
8	Output 5 (Optically-Isolated)	Output	
9	Output 6 (Optically-Isolated)	Output	
10	Output 7 (Optically-Isolated)	Output	

Table 3-16: Digital Output Mating Connector Ratings [-EB1]

Specification	Description
Type	10-Pin Terminal Block
Part Numbers	Aerotech: ECK02395
	Phoenix: 1700841
Conductor Cross Section	Solid or stranded
	Stranded, with ferrule, without plastic sleeve
Conductor Insulation Strip Length	8 mm (5/16 in)
(1) Refer to the manufacturer website for additional information.	

Figure 3-11: Digital Outputs Schematic [-EB1]

Figure 3-12: Digital Outputs Connected in Current Sourcing Mode [-EB1]

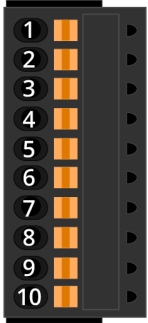
Digital Output Connector [-EB1]

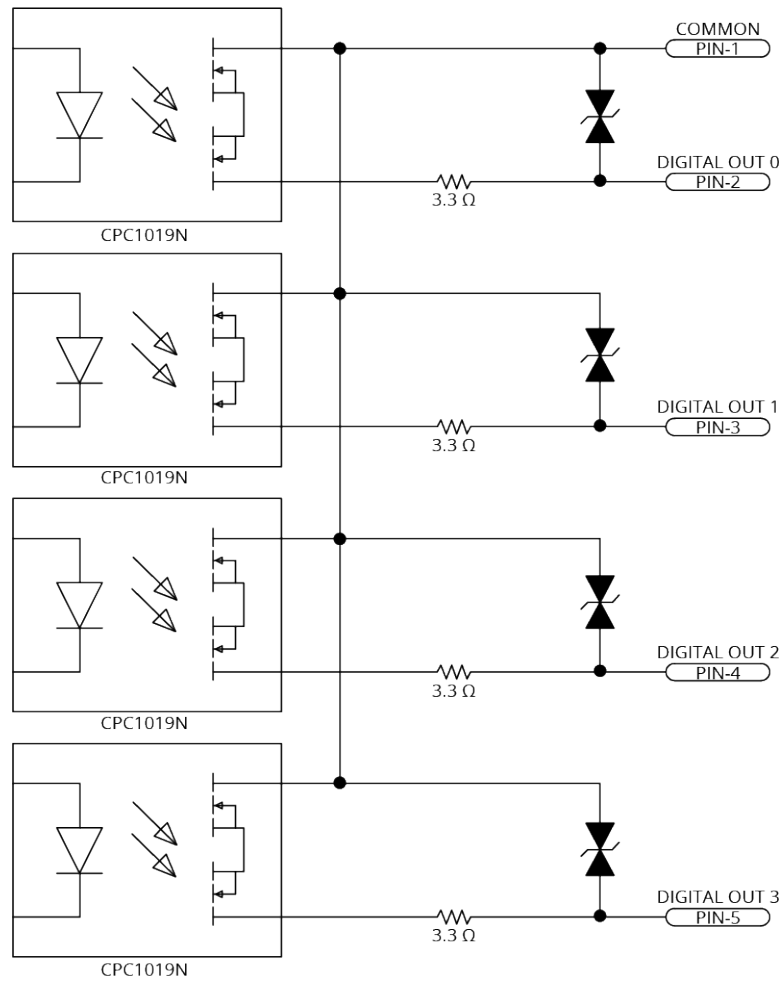
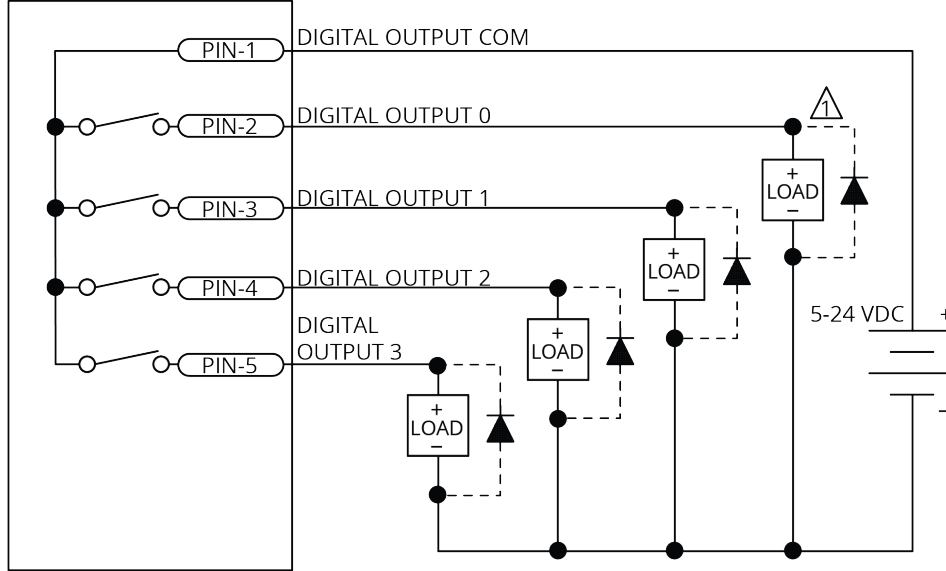

DIODE REQUIRED ON EACH OUTPUT THAT DRIVES AN INDUCTIVE DEVICE (COIL), SUCH AS A RELAY.

Figure 3-13: Digital Outputs Connected in Current Sinking Mode [-EB1]

Digital Output Connector [-EB1]

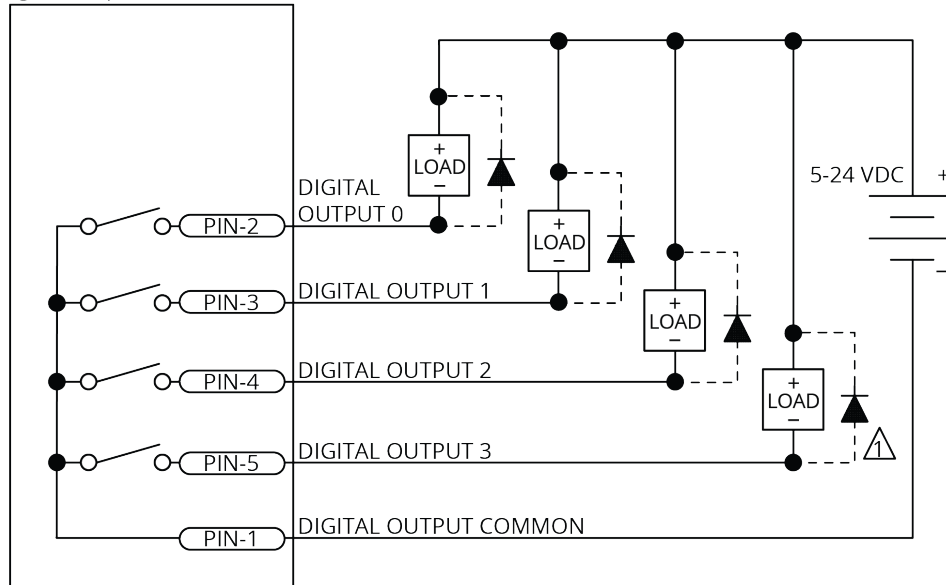

DIODE REQUIRED ON EACH OUTPUT THAT DRIVES AN INDUCTIVE DEVICE (COIL), SUCH AS A RELAY.

3.5. Digital Inputs [-EB1]

Input bits are arranged in groups of 4 and each group shares a common pin. This lets a group be connected to current sourcing or current sinking devices, based on the connection of the common pin in that group.

To be able to connect an input group to current sourcing devices, connect the input group's common pin to the power supply return (-). Refer to [Figure 3-15](#).

To be able to connect an input group to current sinking devices, connect the input group's common pin to the power supply source (+). Refer to [Figure 3-16](#).

The digital inputs are not designed for high-voltage isolation applications. They should only be used with ground-referenced circuits.

Table 3-17: Digital Input Specifications [-EB1]

Input Voltage	Approximate Input Current	Turn On Time	Turn Off Time
+5 V to +24 V	6 mA	10 μ s	43 μ s

Table 3-18: Digital Input Connector Pinout [-EB1]

Pin#	Description	In/Out/Bi	Connector
1	Input Common for Inputs 0-3	Output	
2	Input 0 (Optically-Isolated)	Input	
3	Input 1 (Optically-Isolated)	Input	
4	Input 2 (Optically-Isolated)	Input	
5	Input 3 (Optically-Isolated)	Input	
6	Input Common for Inputs 4-7	Output	
7	Input 4 (Optically-Isolated)	Input	
8	Input 5 (Optically-Isolated)	Input	
9	Input 6 (Optically-Isolated)	Input	
10	Input 7 (Optically-Isolated)	Input	

Table 3-19: Digital Input Mating Connector Ratings [-EB1]

Specification		Description
Type		10-Pin Terminal Block
Part Numbers		Aerotech: ECK02395 Phoenix: 1700841
Conductor Cross Section	Solid or stranded	20...26 AWG (0.14...0.5 mm ²)
	Stranded, with ferrule, without plastic sleeve	20...24 AWG (0.25...0.5 mm ²)
Conductor Insulation Strip Length		8 mm (5/16 in)
(1) Refer to the manufacturer website for additional information.		

Figure 3-14: Digital Inputs Schematic [-EB1]

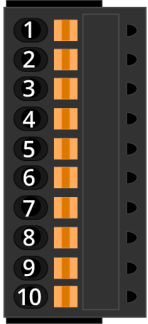
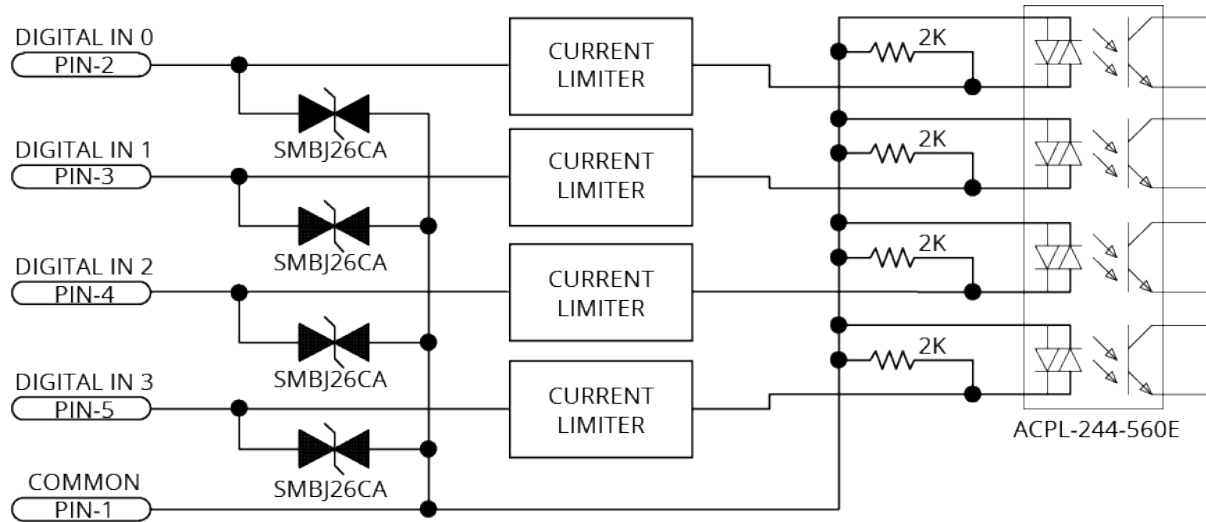

Each bank of four inputs must be connected in an all sourcing or all sinking configuration.

Figure 3-15: Digital Inputs Connected to Current Sourcing (PNP) Devices [-EB1]

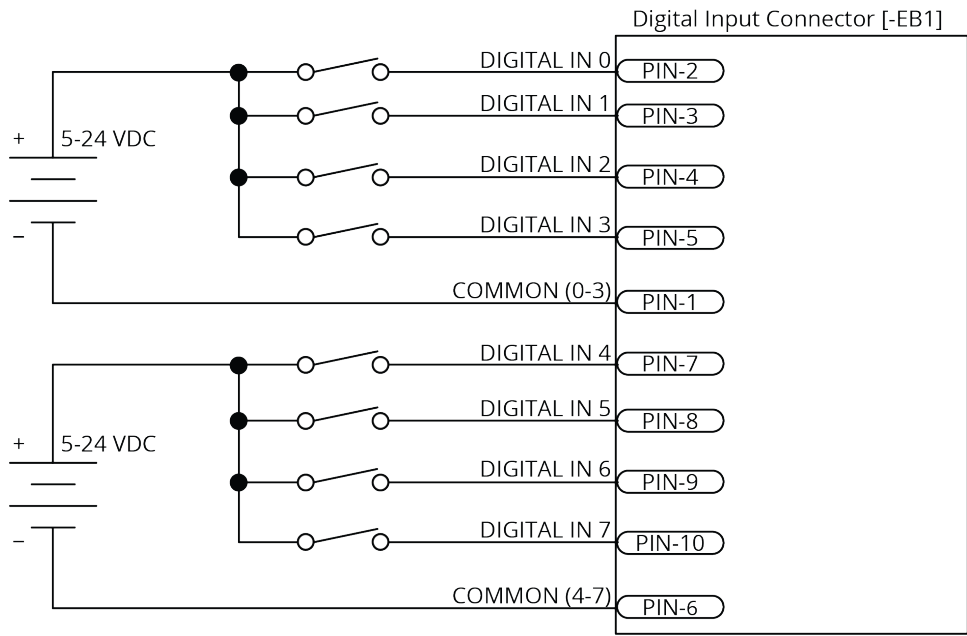
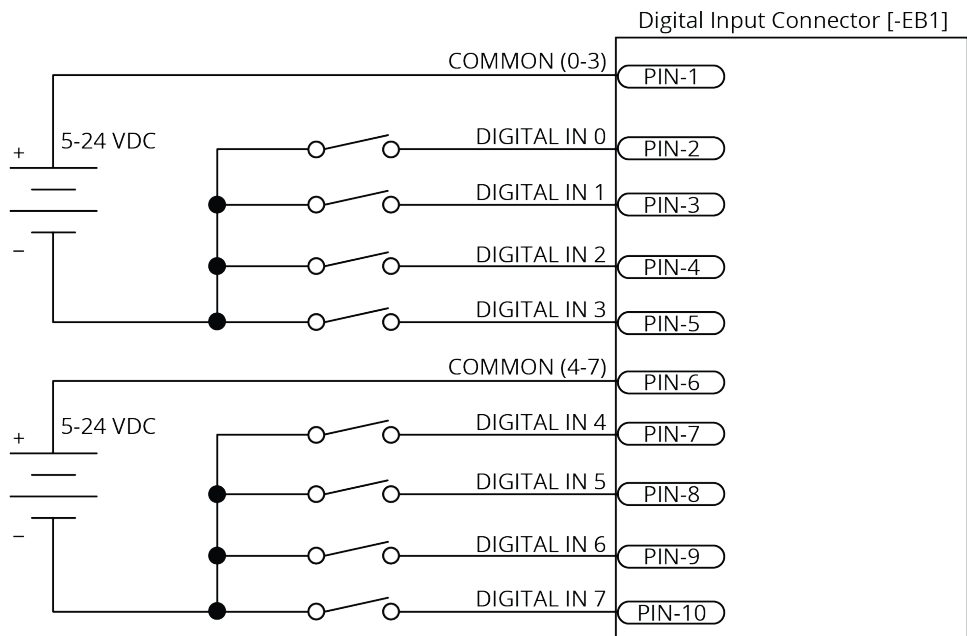

Figure 3-16: Digital Inputs Connected to Current Sinking (NPN) Devices [-EB1]



3.6. Industrial Ethernet (iXC2e -EB2 Option Only)

The controller is equipped with 100BASE-TX Industrial Ethernet ports.



IMPORTANT: Industrial Ethernet is only available on the iXC2e -EB2 Option.

- For the location of the ports, refer to [Figure 1-1](#).
- For cable part numbers, refer to [Table 4-1](#).
- For more information, refer to the Help system.

This page intentionally left blank.

Chapter 4: Cables and Accessories



IMPORTANT: Find Aerotech cable drawings on the website at <http://www.aerotechmotioncontrol.com/manuals/index.aspx>.

Table 4-1: Standard Interconnection Cables

Cable Part #	Description
Joystick	Refer to Section 4.2. Joystick Interface
Handwheel	Refer to Section 4.3. Handwheel Interface
ECZ03125-3 and ECZ03125-9	Dual-PSO Adapter Cable (refer to Section 4.4. Dual-PSO Adapter Cable).
C20934-XX or C20935-XX ⁽¹⁾	BB-MP Interconnect Cable (Refer to the BB-MP manual)
ENET-CAT5e-xx ^(1, 2)	Ethernet CAT5e Cable
USB-AMCM-xx ^(1, 2)	USB Cable A-Male to C-Male
(1) The "-xx" indicates length in decimeters.	
(2) iXC2e Only	

4.1. DIN Rail Mounting

DIN Rail Mounting Procedure:

1. Mount the DIN rail clip to the drive. The clip and #6-32 x 1/4 flat head screws are included in the HyperWire-DIN clip kit.
2. Cut the DIN rail so that one complete mounting hole extends beyond the last component at each end.
3. Secure the DIN Rail to the mounting surface with #10-32 screws spaced every six inches.
NOTE: Do not install the DIN rail to the mounting surface with the components already attached.
4. Install all components on to the DIN rail.



IMPORTANT: Refer to the Automation1 PS2 DIN Rail Power Supply hardware manual for more information.

Table 4-2: Mounting Parts

	Aerotech P/N
DIN Rail	EAM00914
DIN Rail Clip Kit	HyperWire-DIN

Figure 4-1: Din Rail Clip Dimensions

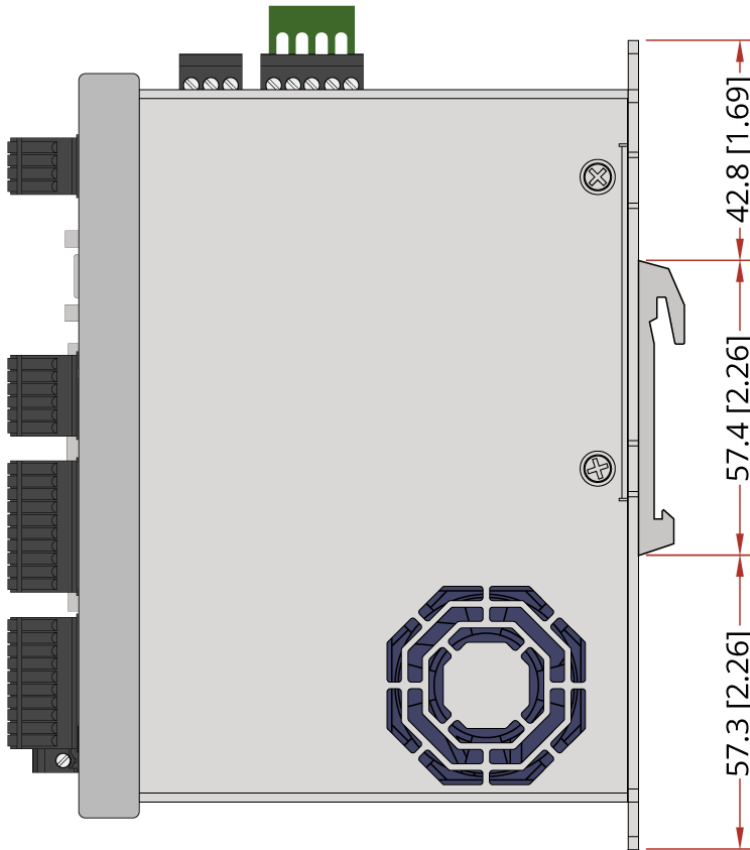

4.2. Joystick Interface

Aerotech Multi-Axis Joystick (NEMA12 (IP54) rated) is powered from 5 V and has a nominal 2.5 V output in the center detent position. Three buttons are used to select axis pairs and speed ranges. Joystick control will not activate unless the joystick is in the center location. Third party devices can be used provided they produce a symmetric output voltage within the range of -10 V to +10 V.

Connecting joystick with an Aerotech cable, all Aerotech cables are labeled to identify the connector and connections. The joystick parameters must be set to match the analog and digital I/O connections. Refer to the [Help file](#) for programming information about how to change joystick parameters.

Figure 4-2: Two Axis Joystick Interface

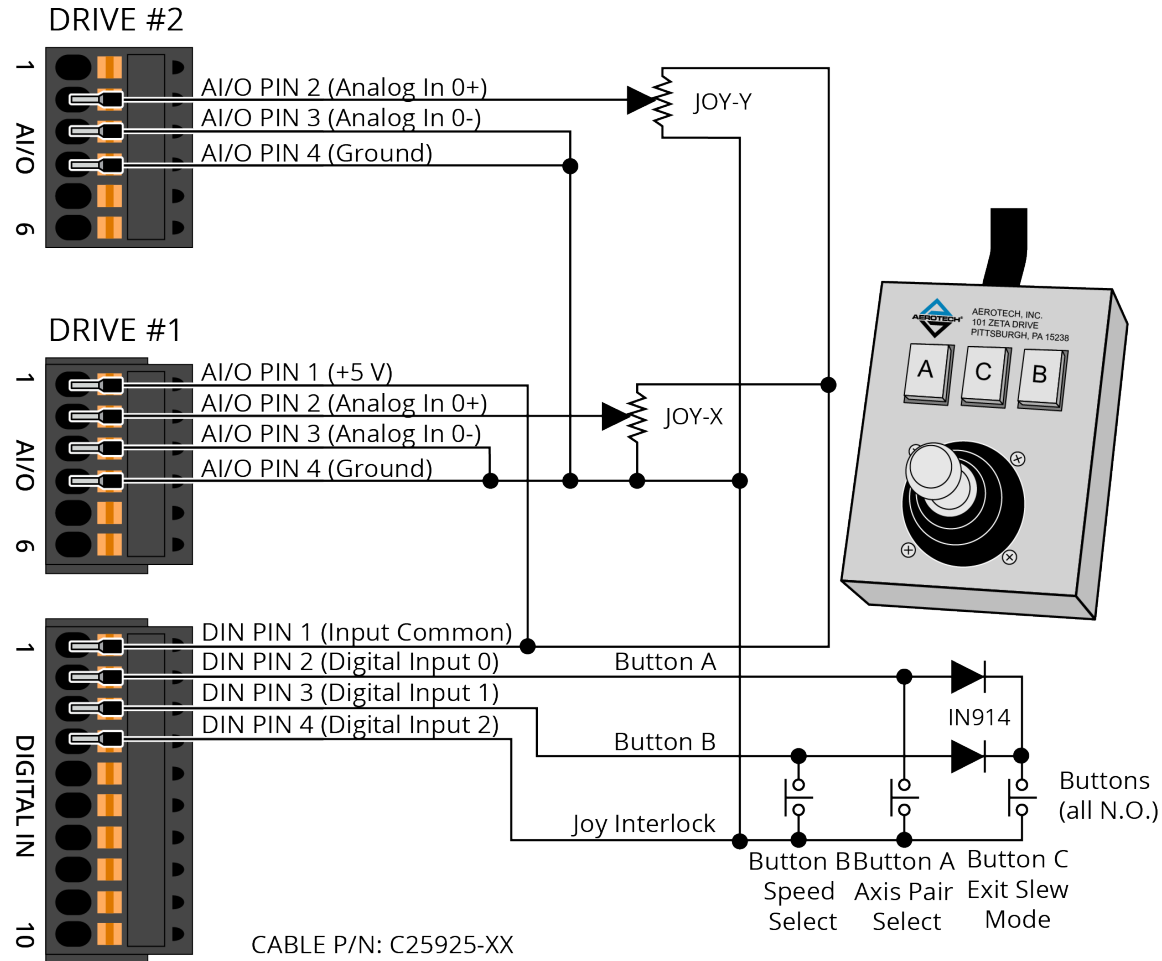

4.3. Handwheel Interface

A handwheel can be used to manually control axis position. The handwheel must provide 5V differential quadrature signals to the drive.



IMPORTANT: You can find instructions on how to enable the handwheel in the online [Help file](#).

Connect a handwheel to the Aux connector as shown in [Figure 4-3](#).

Figure 4-3: Handwheel Interconnection to the Aux Connector

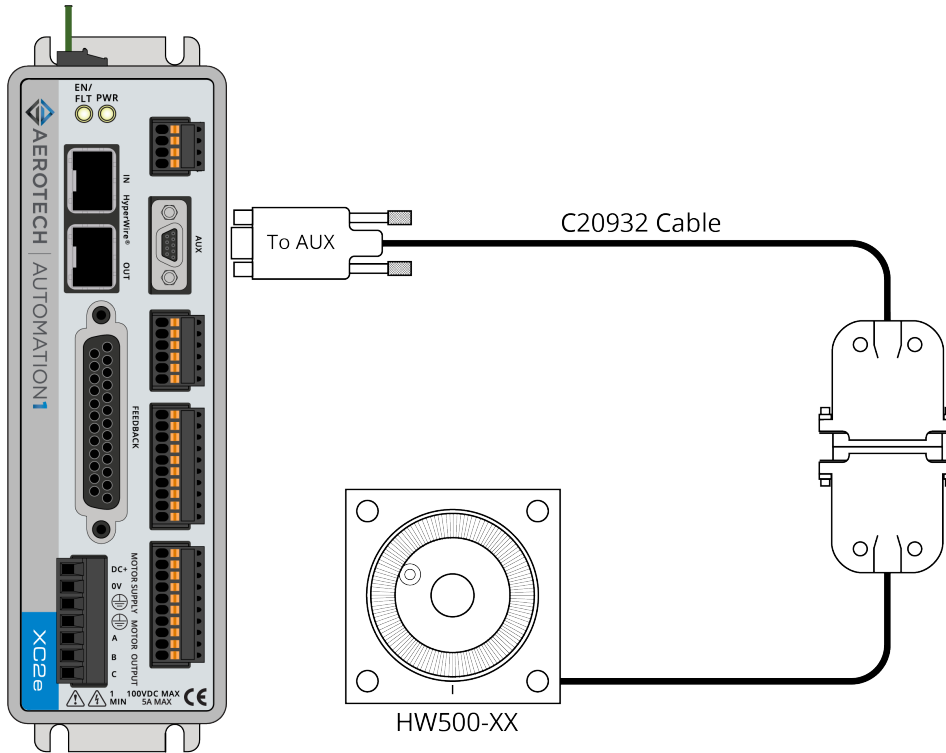

4.4. Dual-PSO Adapter Cable

The dual-PSO adapter cable is available in two lengths:

3 dm (9.84 in)

9 dm (29.52 in)

Figure 4-4: Dual-Axis PSO Cable Connection

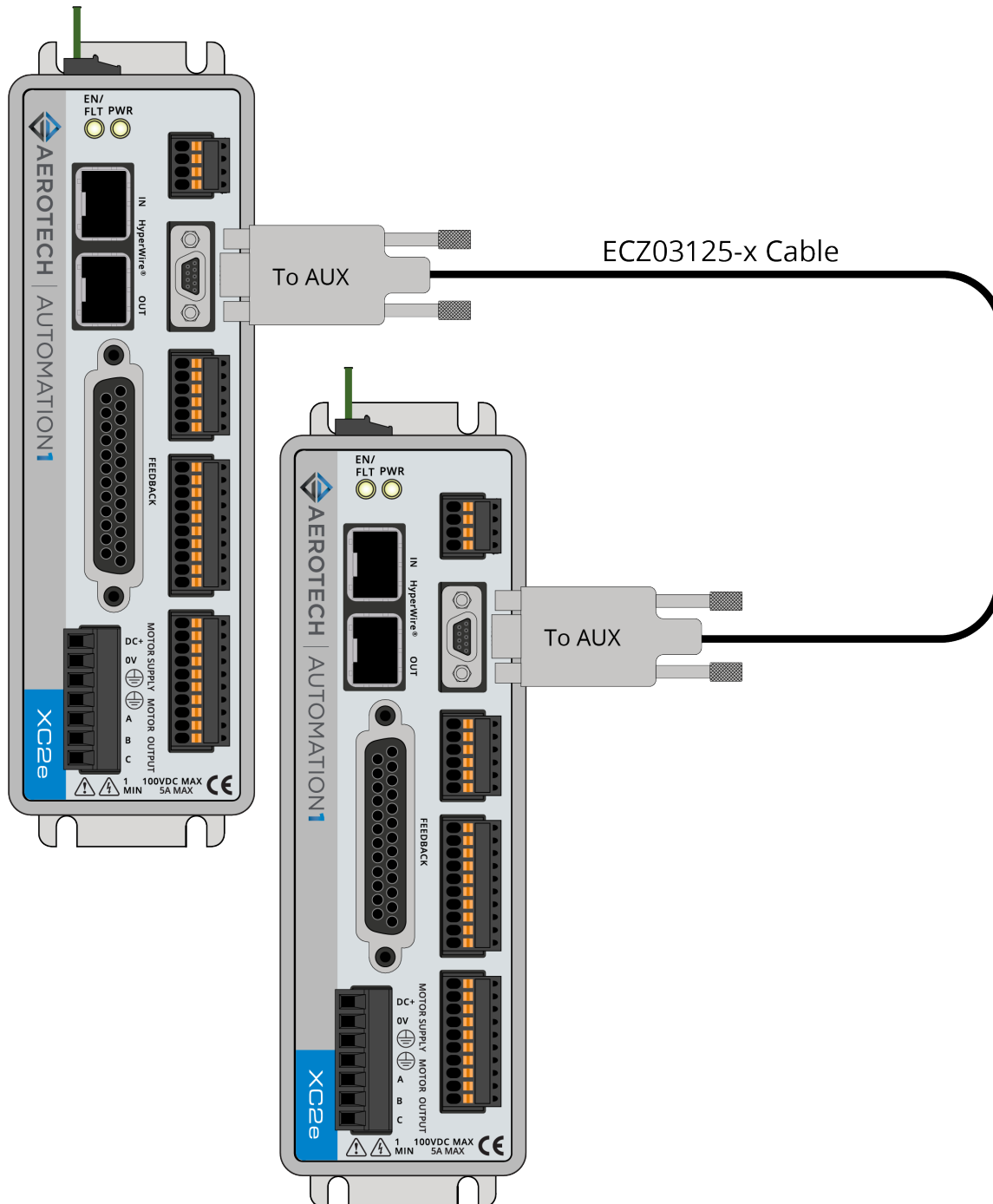

This page intentionally left blank.

Chapter 5: Maintenance



IMPORTANT: For your own safety and for the safety of the equipment:

- Do not remove the cover of the iXC2e/XC2e.
- Do not attempt to access the internal components.

A fuse that needs to be replaced indicates that there is a more serious problem with the system or setup. Contact Global Technical Support for assistance.



DANGER: If you must remove the covers and access any internal components be aware of the risk of electric shock.

1. Disconnect the Mains power connection.
2. Wait at least one (1) minute after removing the power supply before doing maintenance or an inspection. Otherwise, there is the danger of electric shock.
3. All tests must be done by an approved service technician. Voltages inside the controller and at the input and output power connections can kill you.

Table 5-1: LED Description

LED	Color	Description
PWR	GREEN	The light will illuminate and remain illuminated while power is applied.
EN/FLT	GREEN	The axis is Enabled.
	RED	The axis is in a Fault Condition.
	GREEN/RED (alternates)	The axis is Enabled in a Fault Condition. or The light is configured to blink for setup.

Table 5-2: Troubleshooting

Symptom	Possible Cause and Solution
No Communication	Make sure the power LED is illuminated (this indicates that power is present).
	Make sure that all communication cables (HyperWire, for example) are fully inserted in their ports.

5.1. Preventative Maintenance

Do an inspection of the iXC2e/XC2e and the external wiring one time each month. It might be necessary to do more frequent inspections based on:

- The operating conditions of the system.
- How you use the system.

Table 5-3: Preventative Maintenance

Check	Action to be Taken
Examine the chassis for hardware and parts that are damaged or loose. It is not necessary to do an internal inspection unless you think internal damage occurred.	Repair all damaged parts.
Do an inspection of the cooling vents.	Remove all material that collected in the vents.
Examine the work area to make sure there are no fluids and no electrically conductive materials.	Do not let fluids and electrically conductive material go into the chassis.
Examine all cables and connections to make sure they are correct.	Make sure that all connections are correctly attached and not loose. Replace cables that are worn. Replace all broken connectors.

Cleaning



DANGER: Before you clean the iXC2e/XC2e, disconnect the electrical power from the drive.

Use a clean, dry, soft cloth to clean the iXC2e/XC2e. If necessary, use a cloth that is moist with water or isopropyl alcohol. If you use a moist cloth, make sure that moisture does not go into the drive. Also make sure that it does not go onto the outer connectors and components. Internal contamination from the cleaning solution can cause corrosion and electrical short circuits.

Do not clean the labels with a cleaning solution because it might remove the label information.

5.2. Fuse Specifications



WARNING: Replace fuses only with the same type and value.

Table 5-4: Control Board Fuse Specifications

Fuse	Description	Size	Aerotech P/N	Third Party P/N
F1	Control Power at +24V Input	2 A S.B.	EIF01066	Littelfuse 0473002.MRT1L
F2	Motor Power at DC+ Input	5 A S.B.	EIF01061	Littelfuse 39215000440

Appendix A: Warranty and Field Service

Aerotech, Inc. warrants its products to be free from harmful defects caused by faulty materials or poor workmanship for a minimum period of one year from date of shipment from Aerotech. Aerotech's liability is limited to replacing, repairing or issuing credit, at its option, for any products that are returned by the original purchaser during the warranty period. Aerotech makes no warranty that its products are fit for the use or purpose to which they may be put by the buyer, whether or not such use or purpose has been disclosed to Aerotech in specifications or drawings previously or subsequently provided, or whether or not Aerotech's products are specifically designed and/or manufactured for buyer's use or purpose. Aerotech's liability on any claim for loss or damage arising out of the sale, resale, or use of any of its products shall in no event exceed the selling price of the unit.

THE EXPRESS WARRANTY SET FORTH HEREIN IS IN LIEU OF AND EXCLUDES ALL OTHER WARRANTIES, EXPRESSED OR IMPLIED, BY OPERATION OF LAW OR OTHERWISE. IN NO EVENT SHALL AEROTECH BE LIABLE FOR CONSEQUENTIAL OR SPECIAL DAMAGES.

Return Products Procedure

Claims for shipment damage (evident or concealed) must be filed with the carrier by the buyer. Aerotech must be notified within thirty (30) days of shipment of incorrect material. No product may be returned, whether in warranty or out of warranty, without first obtaining approval from Aerotech. No credit will be given nor repairs made for products returned without such approval. A "Return Materials Authorization (RMA)" number must accompany any returned product(s). The RMA number may be obtained by calling an Aerotech service center or by submitting the appropriate request available on our website (www.aerotech.com). Products must be returned, prepaid, to an Aerotech service center (no C.O.D. or Collect Freight accepted). The status of any product returned later than thirty (30) days after the issuance of a return authorization number will be subject to review.

Visit [Global Technical Support Portal](#) for the location of your nearest Aerotech Service center.

Returned Product Warranty Determination

After Aerotech's examination, warranty or out-of-warranty status will be determined. If upon Aerotech's examination a warranted defect exists, then the product(s) will be repaired at no charge and shipped, prepaid, back to the buyer. If the buyer desires an expedited method of return, the product(s) will be shipped collect. Warranty repairs do not extend the original warranty period.

Fixed Fee Repairs - Products having fixed-fee pricing will require a valid purchase order or credit card particulars before any service work can begin.

All Other Repairs - After Aerotech's evaluation, the buyer shall be notified of the repair cost. At such time the buyer must issue a valid purchase order to cover the cost of the repair and freight, or authorize the product(s) to be shipped back as is, at the buyer's expense. Failure to obtain a purchase order number or approval within thirty (30) days of notification will result in the product(s) being returned as is, at the buyer's expense.

Repair work is warranted for ninety (90) days from date of shipment. Replacement components are warranted for one year from date of shipment.

Rush Service

At times, the buyer may desire to expedite a repair. Regardless of warranty or out-of-warranty status, the buyer must issue a valid purchase order to cover the added rush service cost. Rush service is subject to Aerotech's approval.

On-site Warranty Repair

If an Aerotech product cannot be made functional by telephone assistance or by sending and having the customer install replacement parts, and cannot be returned to the Aerotech service center for repair, and if Aerotech determines the problem could be warranty-related, then the following policy applies:

Aerotech will provide an on-site Field Service Representative in a reasonable amount of time, provided that the customer issues a valid purchase order to Aerotech covering all transportation and subsistence costs. For warranty field repairs, the customer will not be charged for the cost of labor and material. If service is rendered at times other than normal work periods, then special rates apply.

If during the on-site repair it is determined the problem is not warranty related, then the terms and conditions stated in the following "On-Site Non-Warranty Repair" section apply.

On-site Non-Warranty Repair

If any Aerotech product cannot be made functional by telephone assistance or purchased replacement parts, and cannot be returned to the Aerotech service center for repair, then the following field service policy applies:

Aerotech will provide an on-site Field Service Representative in a reasonable amount of time, provided that the customer issues a valid purchase order to Aerotech covering all transportation and subsistence costs and the prevailing labor cost, including travel time, necessary to complete the repair.

Service Locations

<http://www.aerotech.com/contact-sales.aspx?mapState=showMap>

USA, CANADA, MEXICO

Aerotech, Inc.
Global Headquarters

CHINA

Aerotech China
Full-Service Subsidiary

GERMANY

Aerotech Germany
Full-Service Subsidiary

TAIWAN

Aerotech Taiwan
Full-Service Subsidiary

UNITED KINGDOM

Aerotech United Kingdom
Full-Service Subsidiary

Appendix B: Revision History

Revision	Description
2.05	Updated Agency Approvals .
2.04	Added support for iXC2e Added support for Industrial Ethernet
2.03	General update
2.02	The following sections have been updated: <ul style="list-style-type: none">• EU Declaration of Conformity• Agency Approvals
2.01	Updated: <ul style="list-style-type: none">• Section 2.5. HyperWire Interface• Section 2.6. System Interconnection• Section 3.2. Auxiliary Encoder Interface [-EB1/-EB2]• Section 3.2.3. Sine Wave Encoder (Auxiliary) [-MX3 Option]
2.00	New Manual

This page intentionally left blank.

Index

-			
-EB1			
Analog Input	72	Analog Input Pins (Analog I/O Connector [-EB1])	72
Analog Outputs	71	Analog Input Typical Connection [-EB1]	72
Auxiliary Encoder Input	66	Analog Output Pins (Analog I/O Connector [-EB1])	71
Digital Inputs	71,76	Analog Output Specifications [-EB1]	71
Digital Outputs	71,73	Analog Output Typical Connection [-EB1]	71
I/O Option Board	63	Analog Outputs [-EB1]	71
Position Synchronized Output (PSO) Interface	64	Aux Connector	
-EB2		Analog Encoder	69
Auxiliary Encoder Input	66	Sine Wave Encoder	69
I/O Option Board	63	AUX Connector Mating Connector Part Numbers	66
Position Synchronized Output (PSO) Interface	64	AUX Connector Pinout	66
-MX2	41	Aux Encoder Connector	
-MX3	41,69	Absolute Encoder	68
		Analog Encoder	41
		RS-422 Line Driver Encoder	67
		Sine Wave Encoder	41
		Square Wave Encoder	67
		Auxiliary Encoder Connector Pinout	66
		Auxiliary Encoder Input [-EB1]	66
		Auxiliary Encoder Input [-EB2]	66
2			
2006/42/EC	9		
2011/65/EU	9		
2014/30/EU	9		
2014/35/EU	9-10		
A			
Absolute Encoder (Aux Encoder)	68		
Absolute Encoder (Feedback Connector)	40		
Absolute Encoder Schematic (Aux Encoder Connector)	68		
Absolute Encoder Schematic (Feedback Connector)	40		
Agency Approvals	10		
Altitude	25		
Ambient Temperature	25		
Analog Encoder (Aux Connector)	69		
Analog Encoder (Aux Encoder)	41		
Analog Encoder Phasing Reference Diagram	69		
Analog Encoder Schematic (Aux Connector)	70		
Analog Encoder Specifications (Aux Connector)	69		
Analog Encoder Specifications (Auxiliary I/O Connector)	69		
Analog Encoder Specifications (Feedback Connector)	41		
Analog I/O (AI/O) Connector [-EB1] Mating Connector Part Numbers	71		
Analog I/O (AI/O) Connector Pinout [-EB1]	71		
Analog Input [-EB1]	72		
		B	
		BiSS absolute encoder	40,68
		Brake Connected to the Feedback Connector	50
		Brake Control Relay Specifications	50
		Brake Output Pins on the Feedback Connector	50
		Brake Outputs (Feedback Connector)	50
		Brushless Motor Configuration (Motor Power Output Connector)	31
		Brushless Motor Connections (Motor Power Output Connector)	31
		Brushless Motor Phasing Goal	33
		Brushless Motor Phasing Oscilloscope Example	33
		Brushless Motor Powered Motor Phasing	32
		Brushless Motor Unpowered Motor and Feedback Phasing	33
		C	
		Cable Wires	
		Brushless Motors	31
		DC Brush Motors	34
		Stepper Motors	35
		Cables	
		HyperWire	57

Cables and Accessories	81	Dimensions with -EB1	24
cables, examining	88	DIN Rail Mounting	82
Check for fluids or electrically conductive material exposure	88	DIN Rail Mounting Procedure	82
Cleaning	88	Drawing number	13
Conducted and Radiated Emissions	9	Drive and Software Compatibility	25
connections, examining	88	Drive IP Rating	
Continuous Output Current specifications	21	IP20	22
Control Board Fuse Specifications	88		
Control Supply Connections	27	E	
Control Supply Connector	27	EAM00914	82
Mating Connector Part Numbers	27	Efficiency of Power Amplifier specifications	21
Pinout	27	Electrical Safety for Power Drive Systems	9
Control Supply specifications	21	Electrical Specifications	21
cooling vents, inspecting	88	Electromagnetic Compatibility (EMC)	9
Customer order number	13	EMC/CE Compliance	29
		Enclosure	
D		IP54 Compliant	22
DC Brush Motor Configuration (Motor Power Output Connector)	34	encoder	
DC Brush Motor Connections (Motor Power Output Connector)	34	absolute	40,68
DC Brush Motor Phasing	34	Encoder (Feedback Connector)	38
Declaration of Conformity	9	Encoder and Hall Signal Diagnostics	32
Differential Analog Input Specifications [-EB1]	72	Encoder Fault Input (Feedback Connector)	46
Digital Input Connector [-EB1] Mating Connector Part Numbers	76	Encoder Fault Input Pin on the Feedback Connector	46
Digital Input Connector Pinout [-EB1]	76	Encoder Phasing	43
Digital Input Specifications [-EB1]	76	Encoder Phasing Reference Diagram	43
Digital Inputs [-EB1]	71,76	Encoder Pins on the Feedback Connector	38
Digital Inputs Connected to a Current Sinking Device [-EB1]	78	End of Travel Limit Input (Feedback Connector)	47
Digital Inputs Connected to a Current Sourcing Device [-EB1]	78	End of Travel Limit Input Connections	48
Digital Inputs Schematic [-EB1]	77	End of Travel Limit Input Diagnostic Display	49
Digital Output Connector [-EB1] Mating Connector Part Numbers	73	End of Travel Limit Input Pins on the Feedback Connector	47
Digital Output Connector Pinout [-EB1]	73	End of Travel Limit Phasing	49
Digital Output Specifications [-EB1]	73	EnDat absolute encoder	40,68
Digital Outputs [-EB1]	71,73	Environmental Specifications	25
Digital Outputs Connected in Current Sinking Mode [-EB1]	75	EU 2015/863	9
Digital Outputs Connected in Current Sourcing Mode [-EB1]	75	examining parts	
Digital Outputs Schematic [-EB1]	74	cables	88
Dimensions	23	connections	88
Dimensions (without -EB1)	23	examining, dangerous fluids	88
		examining, dangerous material	88
		F	
		Feature Summary	19
		Feedback Connector	37
		Absolute Encoder	40

Brake Outputs	50	Positive Motor Direction	32
Encoder	38	PSO Isolated Output Sinks Current	65
Encoder Fault Input	46	PSO Isolated Output Sources Current	65
End of Travel Limit Input	47	PSO TTL Outputs Schematic	65
Hall-Effect Inputs	44	Sine Wave Encoder Schematic (Aux Connector)	70
Home Limit Input	47	Square Wave Encoder Schematic (Feedback Connector)	39
Pinout	37	Square Wave Encoder Schematic [-EB1]	67
Primary Encoder	38	Stepper Motor Configuration	35
RS-422 Line Driver Encoder	39	STO Timing	56
Square Wave Encoder	39	Thermistor Input Schematic	45
Thermistor Input	45	Three Phase Stepper Motor Configuration	36
Travel Limit Input	47	TTL Outputs Schematic (PSO)	65
Feedback Monitoring	32	Typical STO Configuration	52
Figure		fluids, dangerous	88
-EB1 Option Board Connectors	63	Functional Diagram	20
-EB2 Option Board Connectors	63	Fuse Specifications	88
Absolute Encoder Schematic (Aux Encoder Connector)	68	Control Supply at L	88
Absolute Encoder Schematic (Feedback Connector)	40	External Shunt (-SX1)	88
Analog Encoder Schematic (Aux Connector)	70	Motor Supply at AC1	88
Analog Input Typical Connection [-EB1]	72		
Analog Output Typical Connection [-EB1]	71	H	
Brake Connected to the Feedback Connector	50	Hall-Effect Feedback Pins on the Feedback Connector	44
Brushless Motor Configuration (Motor Power Output Connector)	31	Hall-Effect Inputs (Feedback Connector)	44
Control Supply Connections	27	Hall-Effect Inputs Schematic	44
DC Brush Motor Configuration (Motor Power Output Connector)	34	Handling	13
Digital Inputs Connected to a Current Sinking Device [-EB1]	78	Handwheel Interconnection to the Aux Connector	84
Digital Inputs Connected to a Current Sourcing Device [-EB1]	78	Handwheel Interface	84
Digital Inputs Schematic [-EB1]	77	Home Limit Input (Feedback Connector)	47
Digital Outputs Schematic [-EB1]	74	Home Limit Input Connections	48
Dimensions (without -EB1)	23	Home Limit Input Diagnostic Display	49
Dimensions with -EB1	24	Home Limit Input Pins on the Feedback Connector	47
End of Travel Limit Input Connections	48	Humidity	25
End of Travel Limit Input Diagnostic Display	49	HyperWire	57
Hall-Effect Inputs Schematic	44	Cable Part Numbers	57
Home Limit Input Connections	48	Card Part Number	57
Home Limit Input Diagnostic Display	49	HyperWire-DIN	82
Isolated Output Current Sinks Schematic (PSO)	65	I	
Isolated Output Current Sources Schematic (PSO)	65	I/O Option Board [-EB1]	63
Motor Supply Connections	28	I/O Option Board [-EB2]	63
Outputs Connected in Current Sinking Mode [-IO]	75	Input Power Connections	27
Outputs Connected in Current Sourcing Mode [-EB1]	75	inspecting cooling vents	88
		Inspection	88

Installation and Configuration	27	Motor Supply Wiring Specifications	28
Installation Overview	14	Mounting and Cooling	22
Introduction	17	Mounting Hardware	22
IP20 Drive IP Rating	22	Mounting Orientation	22
IP54 Compliant Enclosure	22		
Isolated Output Current Sinks Schematic (PSO)	65	O	
Isolated Output Current Sources Schematic (PSO)	65	Operation	25
		Output Voltage specifications	21
J		Overview	17
Joystick Interface	83		
		P	
M		packing list	13
Maintenance	87	PC Configuration and Operation Information	61
material, electrically conductive	88	Peak Output Current specifications	21
Mating Connector P/N		Phasing	
Analog I/O (AI/O) Connector [-EB1]	71	DC Brush Motor	34
AUX Connector	66	End of Travel Limits	49
Control Supply Connector	27	Powered Brushless Motor	32
Digital Input Connector [-EB1]	76	Stepper Motor	35-36
Digital Output Connector [-EB1]	73	Unpowered Brushless Motor/Feedback	33
Feedback Connector	37	Pinout	
Motor Power Output Connector	30	Analog I/O (AI/O) Connector [-EB1]	71
Motor Supply Connector	28	Analog Input Pins (Analog I/O Connector [-EB1])	72
PSO Connector [-EB1]	64	Analog Output Pins (Analog I/O Connector [-EB1])	71
STO Connector	51	Brake Output Pins (Feedback Connector)	50
Mechanical Specifications	22	Control Supply Connector Wiring	27
Minimizing Conducted, Radiated, and System Noise for EMC/CE Compliance	29	Digital Input Connector [-EB1]	76
Minimum Load Inductance specifications	21	Digital Output Connector [-EB1]	73
Modes of Operation	21	Encoder (Feedback Connector)	38
Motor Connector		Encoder Fault Input Pin (Feedback Connector)	46
Mating Connector Part Numbers	37	End of Travel Limit Input Pins (Feedback Connector)	47
Motor Function Relative to STO Input State	55	Feedback Connector	37
Motor Power Output Connector	30	Hall-Effect Feedback Pins (Feedback Connector)	44
Brushless Motor Connections	31	Home Limit Input Pins (Feedback Connector)	47
DC Brush Motor Connections	34	Motor Power Output Connector	30
Mating Connector Part Numbers	30	Primary Encoder (Feedback Connector)	38
Pinout	30	PSO Interface Connector [-EB1]	64
Stepper Motor Connections	35	STO Connector	51
Three Phase Stepper Motor Connections	36	Thermistor Input Pin (Feedback Connector)	45
Motor Supply Connections	28	Pollution	25
Motor Supply Connector	28	Position Feedback in the Diagnostic Display	43
Mating Connector Part Numbers	28	Position Synchronized Output (PSO) Interface [-EB1]	64
Motor Supply specifications	21	Position Synchronized Output (PSO) Interface [-EB2]	64
		Positive Motor Direction	32

Power Amplifier Bandwidth specifications	21	Differential Analog Input [-EB1]	72
Power Requirements	21	Digital Inputs [-EB1]	76
Preventative Maintenance	88	Digital Outputs [-EB1]	73
Primary Encoder (Feedback Connector)	38	Motor Supply Wiring	28
Primary Encoder Pins on the Feedback Connector	38	PSO [-EB1]	64
Procedure		RS-422 Encoder (Feedback Connector)	39,67
DIN Rail Mounting	82	Sine Wave Encoder (Aux Connector)	69
Protective Features	21	Sine Wave Encoder (Auxiliary I/O Connector)	69
PSO		Sine Wave Encoder (Feedback Connector)	41
Isolated Output Sinks Current Schematic	65	Square Wave Encoder (Feedback Connector)	39,67
Isolated Output Sources Current Schematic	65	STO Electrical Specifications	52
TTL Outputs Schematic	65	Unit Weight	22
PSO Connector [-EB1] Mating Connector Part Numbers	64	Square Wave Encoder	39
PSO Interface Connector Pinout [-EB1]	64	Square Wave Encoder (Aux Encoder)	67
PSO Specifications [-EB1]	64	Square Wave Encoder Schematic (Feedback Connector)	39
PWM Switching Frequency specifications	21	Square Wave Encoder Schematic [-EB1]	67
		Square Wave Encoder Specifications (Feedback Connector)	39,67
		Standard Features	19
R		Stepper Motor Configuration	35
Resolute absolute encoder	40,68	Stepper Motor Connections (Motor Power Output Connector)	35
Revision History	91	Stepper Motor Phasing	35-36
RS-422 Encoder Specifications (Feedback Connector)	39,67	STO	51
RS-422 Line Driver Encoder	39	Connector Pinout	51
RS-422 Line Driver Encoder (Aux Encoder Connector)	67	Diagnostics	56
		Electrical Specifications	52
		External Delay Timer	54
		Functional Description	54
		Mating Connector Part Numbers	51
		Motor Function Relative to the STO Input State	55
		Signal Delay	55
		Standards	53
		Standards Data	53
		Startup Validation Testing	55
		Timing	56
		Typical Configuration	52
		Storage	13
		System part number	13
		System Power Requirements	21
		T	
		Table of Contents	3
		Thermistor Input (Feedback Connector)	45
		Thermistor Input Pin on the Feedback Connector	45

Thermistor Input Schematic	45
Three Phase Stepper Motor Configuration	36
Three Phase Stepper Motor Connections (Motor Power Output Connector)	36
Travel Limit Input (Feedback Connector)	47
TTL Outputs Schematic (PSO)	65
Two Axis Joystick Interface	83
Typical STO Configuration	52

U

Unit Weight	22
Use	25
User Power Supply specifications	21

W

Warranty and Field Service	89
Wire Colors for Aerotech-Supplied Brushless Motor Cables	31
Wire Colors for Aerotech-Supplied DC Brush Motor Cables	34
Wire Colors for Aerotech-Supplied Stepper Motor Cables	35