



CCS Hardware Manual

Revision: 1.04.00



Global Technical Support

Go to www.aerotech.com/global-technical-support for information and support about your Aerotech products. The website supplies software, product manuals, Help files, training schedules, and PC-to-PC remote technical support. If necessary, you can complete Product Return (RMA) forms and get information about repairs and spare or replacement parts. To get help immediately, contact a service office or your sales representative. Include your customer order number in your email or have it available before you call.

United States (World Headquarters)	
Email: Support@aerotech.com Phone: +1-412-967-6440 Fax: +1-412-967-6870	101 Zeta Drive Pittsburgh, PA 15238-2811 www.aerotech.com
United Kingdom	China
Email: Support@aerotech.com Phone: +44 (0)1256 855055 Fax: +44 (0)1256 855649	Email: Support@aerotech.com Phone: +86 (21) 5508 6731
Germany	Taiwan
Email: Support@aerotech.com Phone: +49 (0)911 967 9370 Fax: +49 (0)911 967 93720	Email: Support@aerotech.com Phone: +886 (0)2 8751 6690
France	
Email: Support@aerotech.com Phone: +33 2 37 21 87 65	

This manual contains proprietary information and may not be reproduced, disclosed, or used in whole or in part without the express written permission of Aerotech, Inc. Product names mentioned herein are used for identification purposes only and may be trademarks of their respective companies.

Copyright © 2014-2020, Aerotech, Inc., All rights reserved.

Aerotech Worldwide

United States ■ France ■ Germany ■ United Kingdom
China ■ Taiwan



Table of Contents

- CCS Hardware Manual** **1**
 - Table of Contents 3
 - List of Figures 4
 - List of Tables 5
 - Safety Procedures and Warnings 6
 - EU Declaration of Incorporation 7
- Chapter 1: Overview** **9**
 - 1.1. Environmental Specifications 11
 - 1.2. Accuracy and Temperature Effects 11
 - 1.3. Basic Specifications 12
- Chapter 2: Mechanical Specifications and Installation** **13**
 - 2.1. Unpacking and Handling the Stage 13
 - 2.2. Dimensions 14
 - 2.3. Securing the Stage to the Mounting Surface 17
 - 2.4. Load Capability 19
 - 2.5. Air Requirements 20
 - 2.6. Wet Cut Fluid Requirements 20
 - 2.7. Mechanical Setup 21
 - 2.8. Changing the Workholding Devices 22
 - 2.8.1. Collet Installation and Removal Procedure for the CCS130DR-160 and
CCS190DR-240-3C 23
 - 2.8.2. Collet Installation and Removal Procedure for the CCS190DR-260-5C 24
- Chapter 3: Electrical Specifications and Installation** **27**
 - 3.1. Motor and Feedback Connectors 28
 - 3.2. Motor and Feedback Wiring 31
 - 3.3. Motor and Feedback Specifications 32
 - 3.4. Limits, Marker, and Machine Direction 35
 - 3.5. Motor and Feedback Phasing 36
- Chapter 4: Maintenance** **39**
 - 4.1. Service and Inspection Schedule 39
 - 4.2. Cleaning and Lubrication 40
 - 4.2.1. Collet & Collet Chuck Lubrication and Cleaning 40
 - 4.3. Seal Replacement 42
 - 4.3.1. Piston Seal Change Procedure 42
 - 4.3.2. Ringseal O-Ring Replacement (CCS130DR-160 with -WCUT option only) 42
 - 4.3.3. Wet Cut Rotary Union Seal Replacement (CCS130DR-160 with -WCUT option
only) 44
 - 4.4. Wet Cut Rotary Union Removal 47
 - 4.5. Wet Cut Maintenance (CCS190DR-240-3C and CCS190DR-260-5C) 49
 - 4.6. Troubleshooting 53
- Appendix A: Warranty and Field Service** **55**
- Appendix B: Revision History** **57**
- Index** **59**

List of Figures

Figure 1-1: CCS Series Rotary Stage 9

Figure 2-1: CCS130DR-160 Dimensions 14

Figure 2-2: CCS190DR-240-3C Dimensions 15

Figure 2-3: CCS190DR-260-5C Dimensions 16

Figure 2-4: Mounting Hole Locations 18

Figure 2-5: CCS130DR-160 Wet Cut Rotary Union Location 19

Figure 2-6: Collet Installation 23

Figure 2-7: CCS190DR-260-5C Collet Retention System Components 24

Figure 2-8: CCS190DR-260-5C Alignment Scribe Marks 25

Figure 3-1: Motor and Feedback Wiring 31

Figure 3-2: Machine Direction 35

Figure 3-3: Hall Phasing 36

Figure 3-4: Analog Encoder Phasing Reference Diagram 37

Figure 3-5: Encoder Phasing Reference Diagram (Standard) 37

Figure 4-1: Collet and Collet Chuck Tapered Surfaces 41

Figure 4-2: Typical Ringseal 42

Figure 4-3: Typical Ringseal Removal 42

Figure 4-4: Cross-section View of Ringseal Showing O-Rings 43

Figure 4-5: Cross-Section View of Wet Cut Rotary Union 44

Figure 4-6: Rear Carriage Cover w/ Wet Cut Rotary Union 45

Figure 4-7: Seal Location 45

Figure 4-8: Wet Cut Rotary Union Shaft Inspection 46

Figure 4-9: Wet Cut Rotary Union 47

Figure 4-10: Housing Assembly Showing Rotary Union 47

Figure 4-11: Rotary Union Removal 48

Figure 4-12: Rear Cover Removal 50

Figure 4-13: Collet-Chuck Piston and Piston Housing Cleaning 50

Figure 4-14: Front Cover and Labyrinth Seal Removal 51

Figure 4-15: Front of Stage Cleaning 51

Figure 4-16: Front Cover Installation 52

List of Tables

Table 1-1: CCS130 Model Numbering System10
Table 1-2: CCS190 Model Numbering System10
Table 1-3: Minimum Environmental Specifications11
Table 1-4: CCS Series Specifications12
Table 2-1: Stage to Mounting Surface Hardware17
Table 3-1: Motor Connector Pinout29
Table 3-2: Feedback Connector Pinout30
Table 3-3: Feedback Specifications32
Table 3-4: Encoder Lines Per Revolution32
Table 3-5: Maximum Speed (rpm)32
Table 3-6: Rotary Motor Specifications for the CCS130DR-16033
Table 3-7: Rotary Motor Specifications for the CCS190DR-240-3C and CCS190DR-260-5C34
Table 4-1: Recommended Lubricants41

Safety Procedures and Warnings



This manual tells you how to carefully and correctly use and operate the CCS.

- Read all parts of this manual before you install or operate the CCS or before you do maintenance to your system.
- To prevent injury to you and damage to the equipment, obey the precautions in this manual.



If you do not understand the information in this manual, contact Aerotech Global Technical Support.

NOTE: Aerotech continually improves its product offerings; listed options may be superseded at any time. All drawings and illustrations are for reference only and were complete and accurate as of this manual's release. Refer to www.aerotech.com for the most up-to-date information.



DANGER: This product contains potentially lethal voltages. To reduce the possibility of electrical shock, bodily injury, or death the following precautions must be followed.

1. Access to the CCS and component parts must be restricted while connected to a power source.
2. Do not connect or disconnect any electrical components or connecting cables while connected to a power source.
3. Disconnect electrical power before servicing equipment.
4. All components must be properly grounded in accordance with local electrical safety requirements.
5. Operator safeguarding requirements must be addressed during final integration of the product.



WARNING: To minimize the possibility of electrical shock, bodily injury or death the following precautions must be followed.

1. Moving parts can cause crushing or shearing injuries. Access to all stage and motor parts must be restricted while connected to a power source.
2. Cables can pose a tripping hazard. Securely mount and position all system cables to avoid potential hazards.
3. Do not expose this product to environments or conditions outside of the listed specifications. Exceeding environmental or operating specifications can cause damage to the equipment.
4. The CCS stage must be mounted securely. Improper mounting can result in injury and damage to the equipment.
5. Use care when moving the CCS stage. Lifting or transporting the CCS stage improperly can result in injury or damage to the CCS.
6. This product is intended for light industrial manufacturing or laboratory use. Use of this product for unintended applications can result in injury and damage to the equipment.
7. If the product is used in a manner not specified by the manufacturer, the protection provided by the product can be impaired and result in damage, shock, injury, or death.
8. Operators must be trained before operating this equipment.
9. All service and maintenance must be performed by qualified personnel.

EU Declaration of Incorporation

Manufacturer: Aerotech, Inc.
101 Zeta Drive
Pittsburgh, PA 15238-2811
USA

herewith declares that the product:
CCS Stage

is intended to be incorporated into machinery to constitute machinery covered by the Directive 2006/42/EC as amended;

and that the following harmonized European standards have been applied:

EN ISO 12100:2010

Safety of machinery - Basic concepts, general principles for design

EN 60204-1:2010

Safety of machinery - Electrical equipment of machines - Part 1: General requirements

and further more declares that

it is not allowed to put the equipment into service until the machinery into which it is to be incorporated or of which it is to be a component has been found and declared to be in conformity with the provisions of the Directive 2006/42/EC and with national implementing legislation, for example, as a whole, including the equipment referred to in this Declaration.

This is to certify that the aforementioned product is in accordance with the applicable requirements of the following Directive(s):

EU 2015/863

Directive, Restricted Substances

Authorized Representative: Simon Smith, European Director
Address: Aerotech Ltd
The Old Brick Kiln, Ramsdell, Tadley
Hampshire RG26 5PR
UK

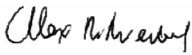
Name  / Alex Weibel
Position Engineer Verifying Compliance
Location Pittsburgh, PA
Date 9/10/2020



This page intentionally left blank.

Chapter 1: Overview

Aerotech's CCS series rotary stages (patent pending) with integrated captured collet chucks provide automated material handling capability for a wide range of materials and applications.

NOTE: Aerotech continually improves its product offerings; listed options may be superseded at any time. All drawings and illustrations are for reference only and were complete and accurate as of this manual's release. Refer to www.aerotech.com for the most up-to-date information.

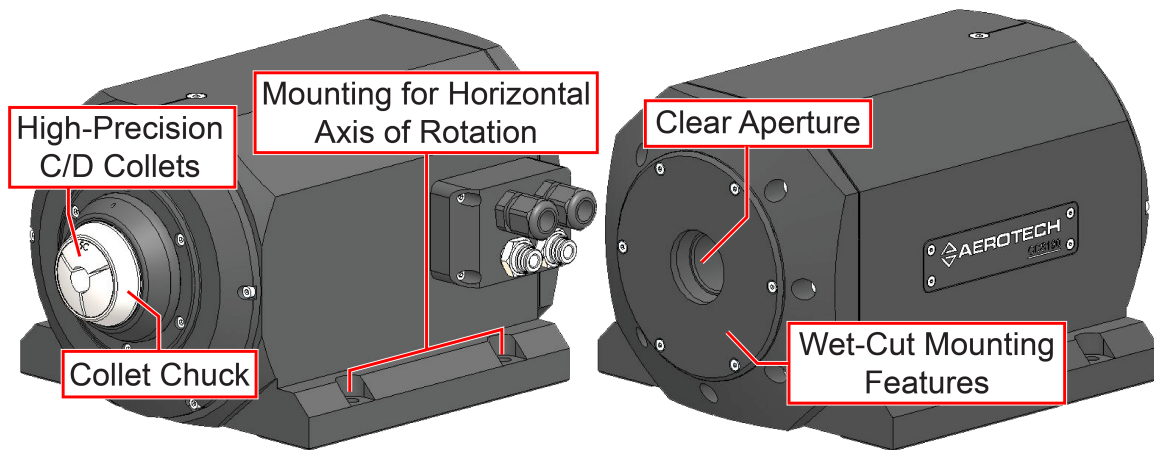

Figure 1-1: CCS Series Rotary Stage

Table 1-1: CCS130 Model Numbering System

CCS130DR Mechanical-Bearing Direct Drive Rotary Collet Stage	
Stage Size (Required)	
-160	160 mm stage height
Cutting Configuration (Required)	
-DCUT	Dry cutting configuration
-WCUT	Wet cutting configuration with fluid rotary union
Note: -WCUT option requires a wet-cut seal with O-ring matched to a specific tube diameter	
Accessories (To be Ordered as a Separate Line Item)	
Collet-D-CLTxxx	Collet, Type-D; consult Aerotech for available sizes
RingSeal-D-RSxx	Ring seal; Type-D collet chuck
CGF	Collet and gripper filtration kit

Table 1-2: CCS190 Model Numbering System

CCS190DR Mechanical-Bearing Direct Drive Rotary Collet Stage	
Stage Size (Required)	
-240-3C	240 mm stage height with 3C collet
-260-5C	260 mm stage height with 5C collet
Wrench (Optional)	
-WR	Wrench for changing collet
Accessories (To be Ordered as a Separate Line Item)	
Collet-3C-CLTxxx	Collet, 3C; consult Aerotech for available sizes
Collet-5C-CLTxxx	Collet, 5C; consult Aerotech for available sizes
CGF	Collet and gripper filtration kit

1.1. Environmental Specifications



WARNING: Do not expose this product to environments or conditions outside of the listed specifications. Exceeding environmental or operating specifications can cause damage to the equipment.

Table 1-3: Minimum Environmental Specifications

Ambient Temperature	Operating: 10° to 35° C (50° to 95° F) The optimal operating temperature is 20° C ±2° C (68° F ±4° F). If at any time the operating temperature deviates from 20° C, degradation in performance could occur.
	Storage: 0° to 40° C (32° to 104° F) in original shipping packaging
Humidity	Operating: 20% to 60% RH
	Storage: 10% to 70% RH, non-condensing in original packaging.
Altitude	Operating: 0 m to 2,000 m (0 ft to 6,562 ft) above sea level Contact Aerotech if your specific application involves use above 2,000 m or below sea level.
Vibration	Use the system in a low vibration environment. Excessive floor or acoustical vibration can affect system performance. Contact Aerotech for information regarding your specific application.
Protection Rating	The CCS stages have limited protection against particles but not liquids. This equates to an ingress protection rating of IP50.
Use	Indoor use only

1.2. Accuracy and Temperature Effects

Aerotech products are designed for and built in a 20°C (68°F) environment. Extreme temperature changes could cause a decrease in performance or permanent damage to the CCS. At a minimum, the environmental temperature must be controlled to within 0.25°C per 24 hours to ensure the CCS specifications are repeatable over an extended period of time. The severity of temperature effects on all specifications depends on many different environmental conditions, including how the CCS is mounted. Contact the factory for more details.

1.3. Basic Specifications

NOTE: Aerotech continually improves its product offerings; listed options may be superseded at any time. All drawings and illustrations are for reference only and were complete and accurate as of this manual's release. Refer to www.aerotech.com for the most up-to-date information.

Table 1-4: CCS Series Specifications

		CCS130DR-160	CCS190DR-240-3C	CCS190DR-260-5C
Travel		360° Continuous		
Accuracy ⁽¹⁾		5 arc sec		
Bidirectional Repeatability		2 arc sec		
Maximum Speed ⁽²⁾		1000 rpm	600 rpm	600 rpm
Aperture ⁽³⁾		7.9 mm (Dry); 3 mm (Wet)	13 mm	26.5 mm
Maximum Torque (Continuous)		0.48 N·m	2.85 N·m	5.06 N·m
Load Capacity ⁽⁴⁾	Axial	2 kg	10 kg	15 kg
	Radial	0.5 kg	5 kg	10 kg
	Moment	0.75 N·m	6 N·m	12 N·m
Rotor Inertia (Unloaded)		0.0004 kg·m ²	0.0039 kg·m ²	0.0051 kg·m ²
Stage Mass		3.1 kg	12.0 kg	14.1 kg
Material		Hardcoat/Anodized Aluminum; Hardened Stainless Steel (Collet Chuck)		
Mean Time Between Failure (MTBF)		10,000 Hours		
Collet Type		Type D (Louis Levin & Sons™)	3C	5C
Collet Runout ⁽⁵⁾		<30 μm	<25 μm	<20 μm
System Air Pressure ⁽⁶⁾⁽⁷⁾ (8)		100 psig	20-100 psig	20-80 psig
<p>1. Calibrated accuracy requires the use of Aerotech controls and angular programming units.</p> <p>2. Maximum speed listed is stage and motor dependent (assuming a 340 V bus). Actual speed may be lower due to motor back emf. Consult Aerotech for more details.</p> <p>3. Dry-Cutting (no ring seal installed) on a system with the -WCUT option limits tube size to 6.7 mm. Wet-cutting (ring-seal required and installed) on a system with the -WCUT option limits tube size to 3.0 mm.</p> <p>4. Maximum loads are mutually exclusive. Loading limits are due to the collet chuck mechanism. Contact Aerotech directly if part load requirement exceeds specifications.</p> <p>5. Measured TIR of a precision gage pin with an ultra precision collet (DIN6499) 3 mm away from the collet face at 80 psig applied air pressure and no load. Measured 6 mm away from collet face at 40 psig applied air pressure for CCS190DR.</p> <p>6. The CCS190DR-240-3C and CCS190DR-260-5C contain a double-acting collet mechanism that requires air to open and close the collet chuck. Aerotech recommends compressed air filtered to 0.25 micron particle size or better.</p> <p>7. Collet chuck mechanism is normally-open (CCS130DR-160). Collet mechanism requires air to close collet chuck. Air supply must be dry (0° F dew point) oil-less air OR 99.99% pure nitrogen. Air or nitrogen must be filtered to 1 micron particle size or better.</p> <p>8. Exceeding the maximum system air pressure on the CCS190 stages is not recommended and could cause damage and/or performance degradation.</p>				

Chapter 2: Mechanical Specifications and Installation



WARNING: CCS installation must be in accordance to instructions provided by this manual and any accompanying documentation. Failure to follow these instructions could result in injury or damage to the equipment.

2.1. Unpacking and Handling the Stage

NOTE: If any damage has occurred during shipping, report it immediately.



- WARNING:** It is the customer's responsibility to safely and carefully lift the stage.
- Make sure that all moving parts are secure before moving the CCS. Unsecured moving parts may shift and cause bodily injury.
 - Improper handling could adversely affect the performance of the CCS. Use care when moving the CCS.
 - Lift only by the base. Do not use the tabletop or cables as lifting points.

Carefully remove the CCS from its protective shipping container. Gently set the CCS on a smooth, flat, and clean surface.

Before operating the CCS, it is important to let it stabilize at room temperature for at least 12 hours. Allowing it to stabilize to room temperature will ensure that all of the alignments, preloads, and tolerances are the same as they were when tested at Aerotech. Use compressed nitrogen or clean, dry, oil-free air to remove any dust or debris that has collected during shipping.

Each CCS has a label listing the system part number and serial number. These numbers contain information necessary for maintaining or updating system hardware and software. Locate this label and record the information for later reference.

2.2. Dimensions

NOTE: Aerotech continually improves its product offerings; listed options may be superseded at any time. All drawings and illustrations are for reference only and were complete and accurate as of this manual's release. Refer to www.aerotech.com for the most up-to-date information.

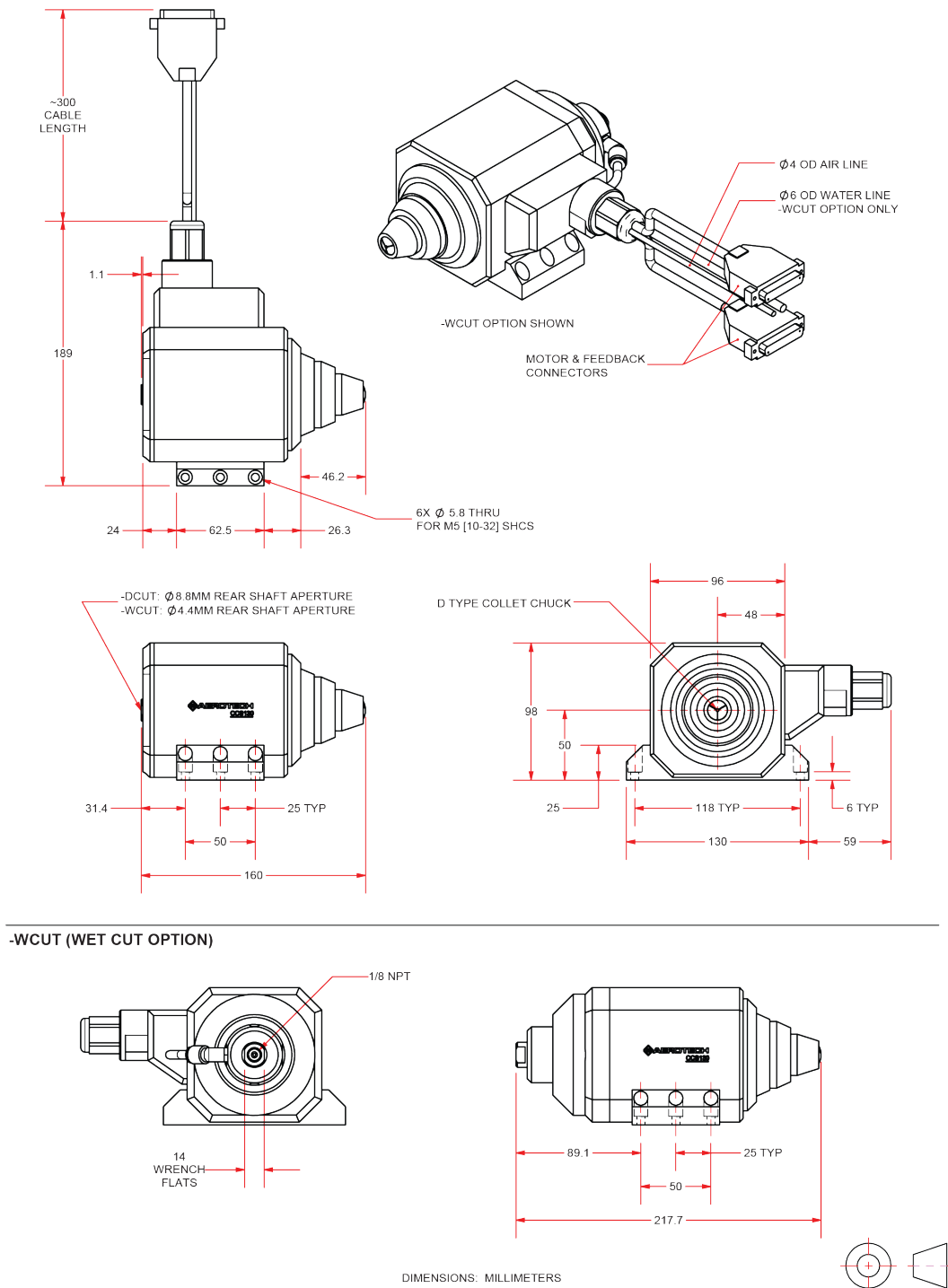

Figure 2-1: CCS130DR-160 Dimensions

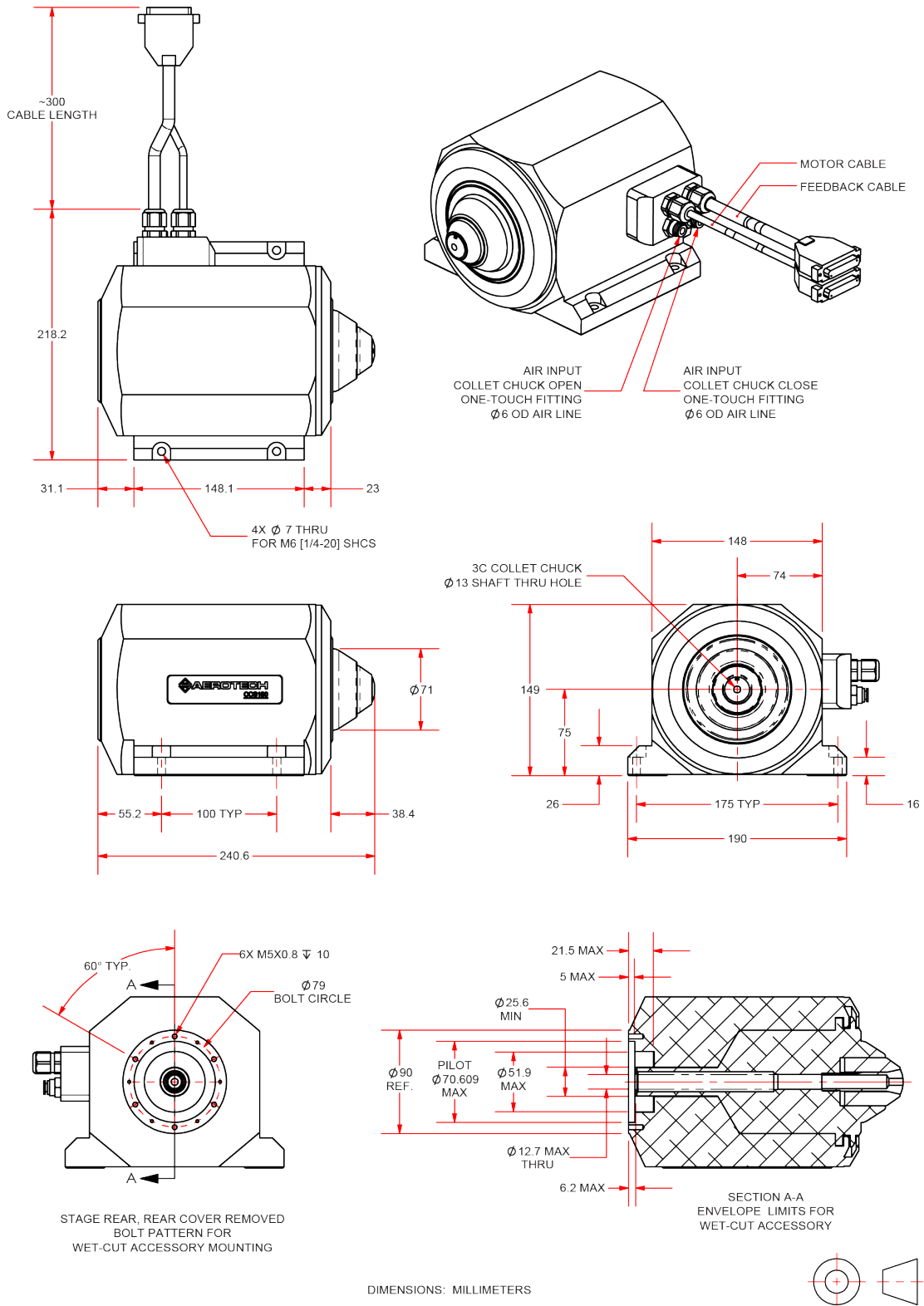

Figure 2-2: CCS190DR-240-3C Dimensions

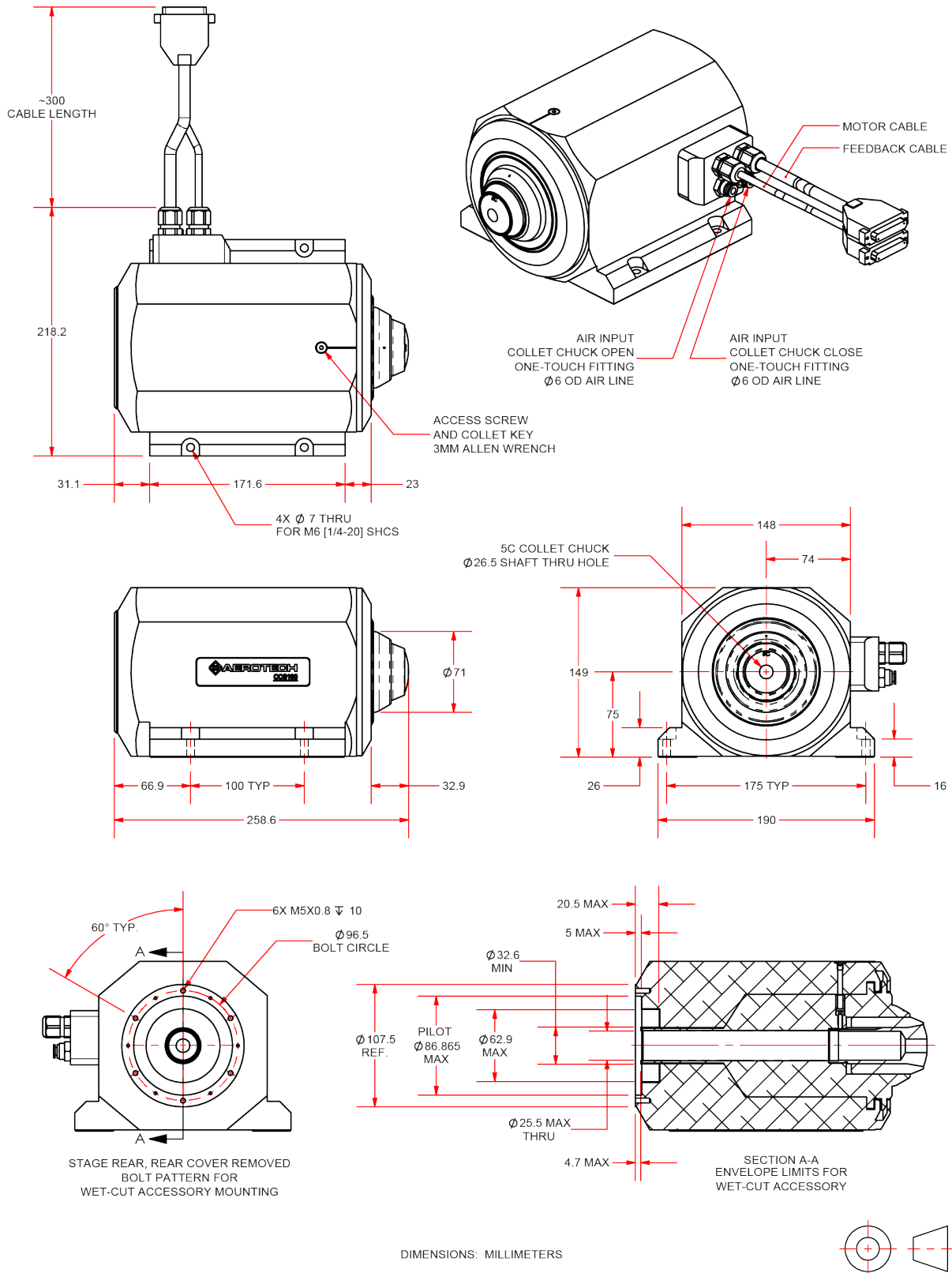

Figure 2-3: CCS190DR-260-5C Dimensions

2.3. Securing the Stage to the Mounting Surface



WARNING: The CCS must be mounted securely. Improper mounting can result in injury and damage to the equipment.



WARNING: Make sure that all moving parts are secure before moving the CCS. Unsecured moving parts may shift and cause bodily injury.



WARNING: Do not attempt to manually move the CCS if it is connected to a power source.



DANGER: PINCH POINT! Keep Hands Clear while the stage is in motion.

The mounting surface must be flat and have adequate stiffness to achieve the maximum performance from the CCS stage. When it is mounted to a non-flat surface, the stage can be distorted while the mounting screws are tightened. This distortion will decrease overall accuracy. Adjustments to the mounting surface must be done before the stage is secured.

Inspect the mounting surface for dirt or unwanted residue and clean if necessary. Use precision flatstones on the mounting surface to remove any burrs or high spots. Clean the mounting surface with a lint-free cloth and acetone or isopropyl alcohol and allow the cleaning solvent to completely dry. Gently place the stage on the mounting surface.

NOTE: The CCS is precision machined and verified for flatness prior to product assembly at the factory. If machining is required to achieve the desired flatness, it should be performed on the mounting surface rather than the CCS. Shimming should be avoided if possible. If shimming is required, it should be minimized to retain maximum rigidity of the system.

NOTE: To maintain accuracy, the mounting surface must be flat to within 1 µm per 50 mm.

CCS series stages have a fixed mounting pattern (as shown in [Figure 2-4](#)).

Tightening torque values for the mounting hardware are dependent on the properties of the surface to which the stage is being mounted. Values provided in [Table 2-1](#) are typical values and may not be accurate for your mounting surface. Refer to [Section 2.2](#) for specific model mounting locations and dimensions.

Table 2-1: Stage to Mounting Surface Hardware

Mounting Hardware		Typical Screw Torque
CCS130DR-160	M5x0.8x14mm long [10-32x1/2 in long] SHCS	4.7 N·m
CCS190DR-240-3C and CCS190DR-260-5C	M6x1.0x25mm long [1/4-20x1 in long] SHCS	8 N·m

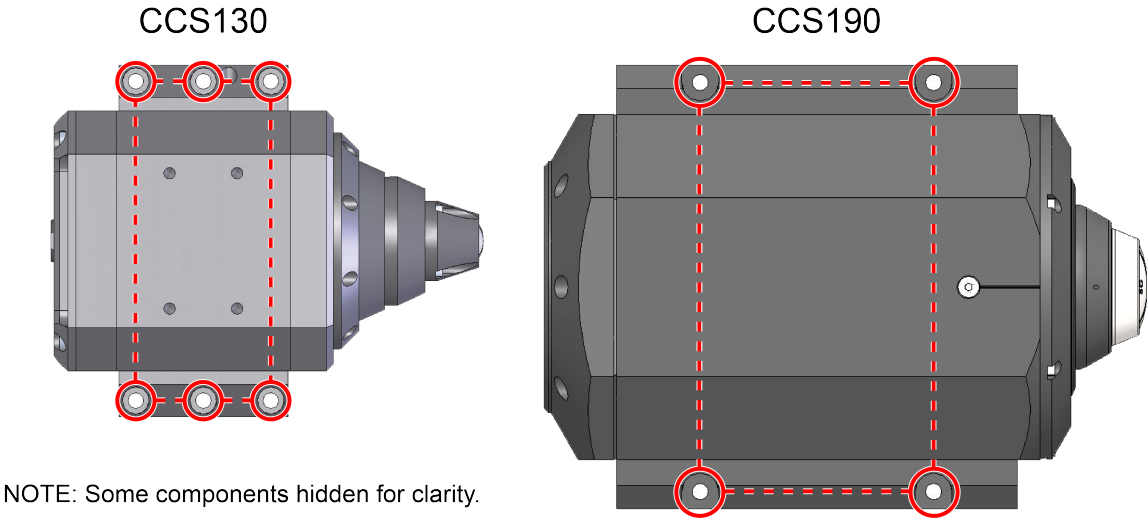

Figure 2-4: Mounting Hole Locations

2.4. Load Capability

The CCS is designed for tubular manufacturing applications. With this in mind, the tubes loaded into the collet chuck of the rotary axis must fall within the maximum load parameters in [Section 1.3](#).

NOTE: Maximum loads are mutually exclusive. Loading limits are due to the collet chuck mechanism. Contact Aerotech directly if part load requirement exceeds specifications.

If the CCS130DR-160 is configured for wet cut, it will have a rotary union attached to the end of the rotary shaft ([Figure 2-5](#)). A 1/8 in NPT tapped hole is provided on the end of the rotary union shaft to allow for connecting a pressure vessel or extension tube. To prevent damage or performance degradation of the stage, the unsupported length and weight of the attached pressure vessel is limited.

NOTE: Aerotech recommends the following limitations on the size and weight of an unsupported pressure vessel:

- Length past end of rotary union (L): <200 mm
- Moment about end of rotary union (M): <0.75 N-m

If these limits are exceeded, it is recommended that an external steady-rest or support be implemented.

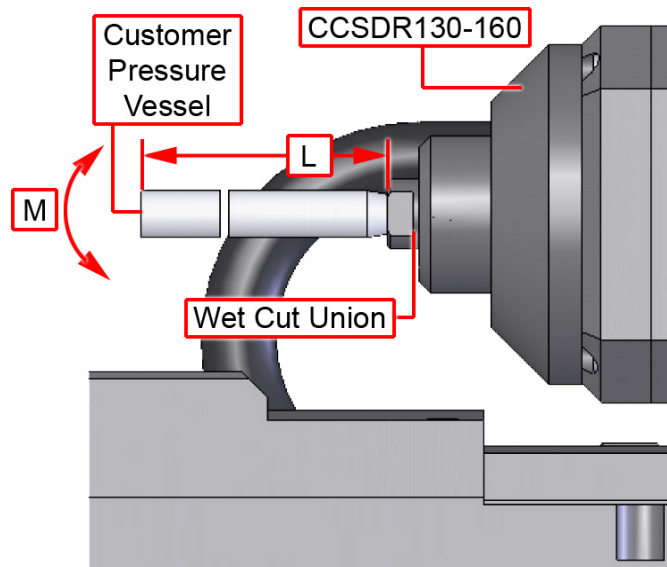

Figure 2-5: CCS130DR-160 Wet Cut Rotary Union Location

2.5. Air Requirements

The air pressure supplied to the collet chuck is important in ensuring that the material or tool is released properly.

- If compressed air is used, it must be filtered to 1 micron, dry to 0° F dew point (CCS130DR-160 only), and oil free.
- If nitrogen is used, it must be 99.99% pure and filtered to 1 micron.

On the CCS130DR-160, the chuck becomes fully closed at approximately 4-7 bar (60-100 psig) depending on the collet size. Higher pressures will not cause damage to the rotary union.

The collet chucks for the CCS190DR-240-3C and the CCS190DR-260-5C close at approximately 1.7 bar (25 psi) depending on collet size. The maximum pressure that should be used on each stage is 6.9 bar (100 psi) and 5.5 bar (80 psi) respectively. Higher pressures are not recommended and could cause damage and/or performance degradation.

The supply pressure for all three stages can be regulated to control the grip force on the workpiece material. Aerotech recommends using the minimum pressure required for the application that securely clamps the workpiece. Lower pressures reduce the possibility of damage to the workpiece, ensures the highest system performance, and increases the longevity of the system.

2.6. Wet Cut Fluid Requirements

Water or cutting fluid used during wet cut operations must be conditioned to meet certain requirements ensuring seal functionality and service life of the wet cut rotary union.

- Water or cutting fluid must be filtered to 5 microns or better.
- A fluid filter must be installed upstream of the rotary union between the pump outlet and the rotary union inlet.

2.7. Mechanical Setup

To prevent damage to the stage or parts, test the operation of the stage before any material is held in the collet.



WARNING: The collet should be removed when testing the initial operation of the stage. Closing the collet chuck on an empty collet can cause damage to the collet.

To operate the collet, nitrogen or clean, dry, oil-less compressed air must be supplied to the stage (refer to [Section 2.5](#)). The CCS130DR-160 stage features a 4 mm OD polyurethane air line that can be connected to the air supply. The CCS190DR-240-3C and CCS190DR-260-5C stages feature one-touch air fittings that accept a 6 mm OD air line (polyurethane, nylon, or fluoropolymer). Insert an air supply into each one-touch fitting on the stage. Due to the dual-acting collet chuck on the CCS190DR-240-3C and CCS190DR-260-5C stages, the two air supplies must be independently controllable for proper operation. Aerotech offers a pneumatics kit and filter/filter-dryer kit to ease air supply setup.

Once an air supply is connected to the stage, the collet chuck can be actuated to check for proper operation. The CCS130DR-160 stage features a normally-open, air actuated collet chuck. Therefore, the collet chuck will remain open until air pressure is supplied to the stage. Turn the air supply on and off to check for proper operation of the collet chuck on this stage. The stage requires 60-100 psig to close.

The CCS190DR-240-3C and CCS190DR-260-5C stages feature a dual-acting, air actuated collet chuck. With these stages, air pressure must be independently supplied to the "Collet Chuck Open" air input or "Collet Chuck Close" air input to actuate the collet chuck. Using Aerotech's solenoid valve setup supplied in the pneumatics kit or by alternatively supplying/removing air pressure to each air input, check for proper operation of the collet chuck. The stages require 25-80/100 psig to close.

Once you have verified that the collet chuck operates properly, a collet can be installed into the stage (refer to [Section 2.8](#)). Appropriately sized material can then be inserted in to the collet. The collet chuck should again be checked for proper operation using the same procedures as before. Aerotech recommends turning the air pressure supply to 0 psi using a precision regulator and slowly increasing pressure until the material is clamped in the collet. Only the minimum amount of air pressure which properly secures the material for the application should be used and should not exceed the maximum system air pressure.



WARNING: The size of material should match the collet size and be inserted into the collet at least 2/3 the length of the collet bore. Material that is larger or smaller than the collet or not inserted far enough into the collet will affect system performance, particularly material runout. In worst-case scenarios, the collet could be damaged and have to be replaced.



WARNING: Exceeding the maximum system air pressure on the CCS190DR-240-3C and CCS190DR-260-5C stages is not recommended and could cause damage and/or performance degradation.

2.8. Changing the Workholding Devices

CCS130DR-160, CCS190DR-240-3C, and CCS190DR-260-5C stages are designed to use Levin D-style, 3C, and 5C collets respectively. It is important that only the collets designed for a particular collet holder are used. Levin Type D precision collets and Hardinge 3C/5C Special Accuracy collets must be used to guarantee the collet runout specifications. Contact the factory for more details.

NOTE: Various grip diameters are commonly available and can be interchanged.

2.8.1. Collet Installation and Removal Procedure for the CCS130DR-160 and CCS190DR-240-3C



DANGER: To minimize the possibility of bodily injury or death, disconnect all electrical power prior to performing any maintenance or making adjustments to the equipment.

CCS stages feature integrated collet retention features. The CCS130DR-160 and CCS190DR-240-3C stages contain ball nose spring plungers to prevent the collet from unthreading during operation.

Collet Removal

- Step 1: Disable and remove power from the stage.
- Step 2: Open the collet chuck to expose the front of the collet in the chuck.
- Step 3: Remove the collet from the chuck by turning it counter-clockwise. When unthreading the collet, you may feel a slight resistance and hear a clicking sound. This is normal and is caused by the ball nose spring plungers dropping into the collet's keyway.
- Step 4: Store the collet in a safe location so it will not be damaged. If the collet is going to be stored for an extended period of time or where moisture is present, it should be coated with a light film of rust preventative oil.

Collet Installation

- Step 1: If you have not already done so, disable and remove power from the stage.
- Step 2: Clean the collet chuck taper and collet including the threads. Acetone or isopropyl alcohol may be used to clean the metal components. For optimum performance, the collet chuck taper and collet must be free of all dirt and debris.
- Step 3: Apply a small amount of general purpose, high viscosity grease or anti-seize lubricant to the collet chuck taper (refer to [Section 4.2.1.](#)).
- Step 4: Verify that the collet chuck is in the open position. Then, guide the collet into the stage ([Figure 2-6](#)) and thread it into the collet chuck. Thread the collet in until it bottoms out and then reverse 1/3 of a turn.
- Step 5: Insert the desired workpiece into the collet. Actuate the collet to the closed position to verify that the workpiece is clamped in the collet. Adjust the collet depth and/or air pressure as required.
- Step 6: Restore power to the stage.

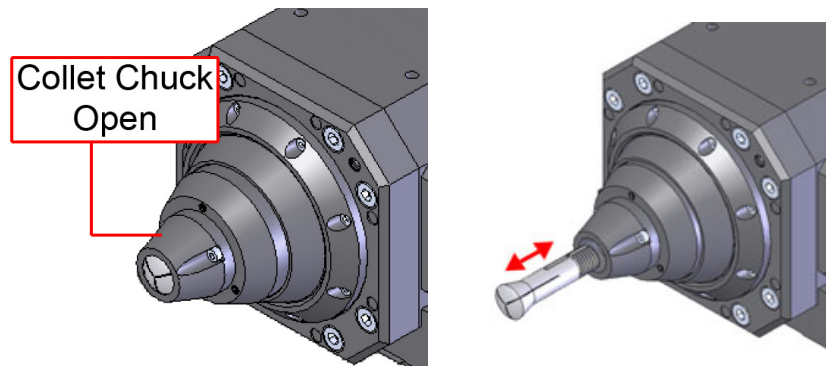

Figure 2-6: Collet Installation

2.8.2. Collet Installation and Removal Procedure for the CCS190DR-260-5C

CCS stages have integrated collet retention features. The CCS190DR-260-5C stage has a positive retention system that consists of a collet retention screw, which fits directly into the collet's keyway and prevents the collet from unthreading.

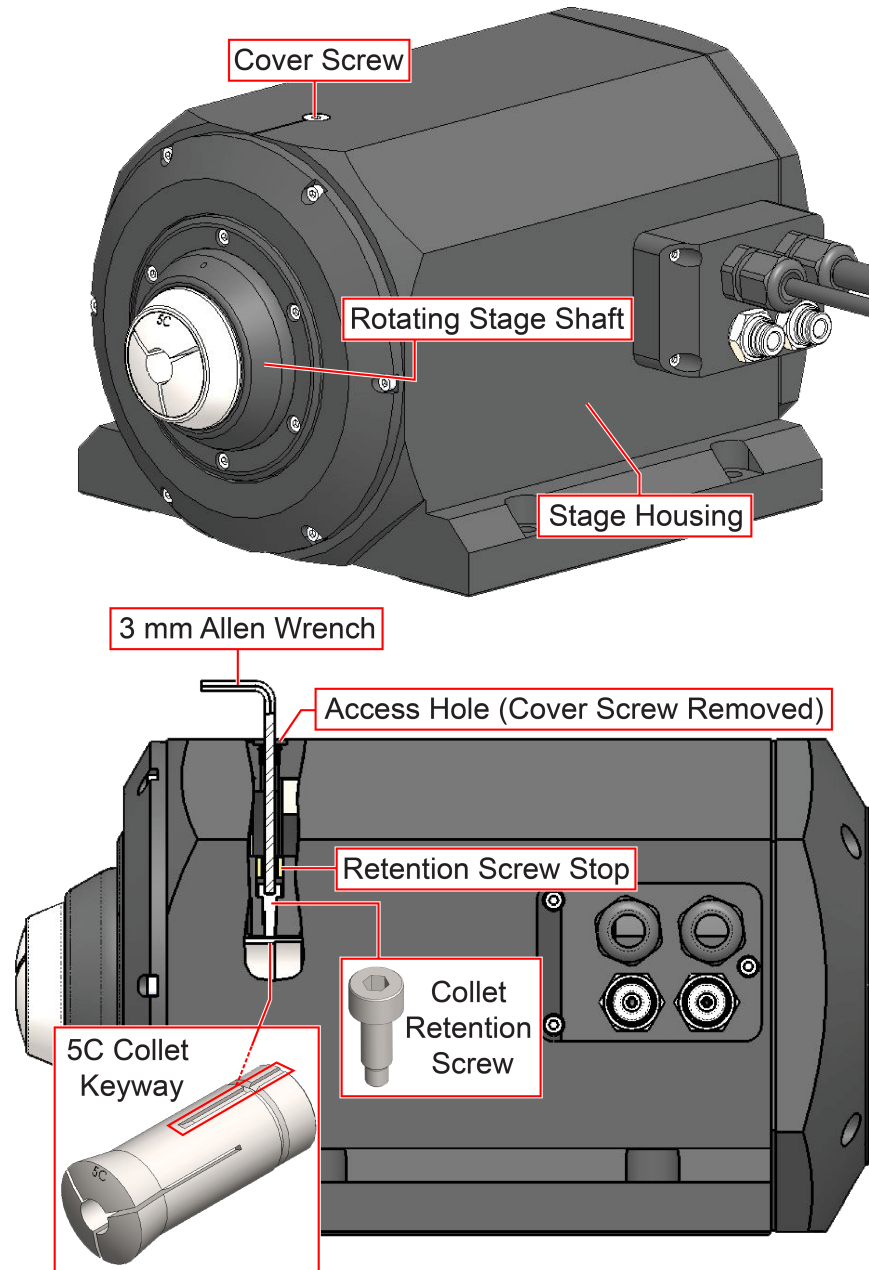

Figure 2-7: CCS190DR-260-5C Collet Retention System Components

Collet Removal

- Step 1: Align the collet retention screw to the access hole in the stage housing by doing one of the instruction sets that follow:
- a. Home the stage
 - b. Disable and remove power from the stage
 - OR-
 - a. Disable and remove power from the stage
 - b. Rotate the stage shaft by hand until the spot-face indicator mark in the stage shaft is aligned with the scribe mark in the top of the stage housing (refer to [Figure 2-8](#)).



DANGER: To minimize the possibility of bodily injury or death, disconnect all electrical power prior to performing any maintenance or making adjustments to the equipment.

NOTE: Scribe marks on the stage shaft and housing along with the collet keyway indicator mark on the collet face must line up for collet removal and installation.

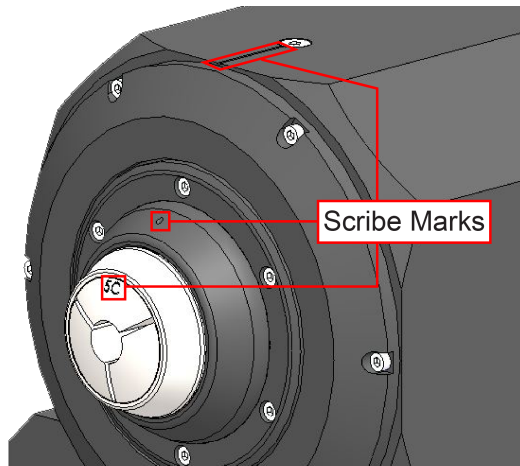

Figure 2-8: CCS190DR-260-5C Alignment Scribe Marks

- Step 2: Remove the cover screw from the top of the stage housing using a 3 mm allen wrench
- Step 3: Insert a 3 mm allen wrench through the access hole revealed beneath the cover screw. The allen wrench will engage the collet retention screw.
- Step 4: Back off the collet retention screw by turning the allen wrench counter-clockwise. This will disengage the retention screw from the collet's keyway.



WARNING: Do not back off the collet retention screw any further than needed to remove the collet. There is a positive stop to prevent the retention screw from becoming loose in the stage housing. However, if the retention screw is forced past the stop, both the stop and the retention screw could become loose in the stage housing and cause damage to the stage.

- Step 5: Remove the collet by turning it counter-clockwise. Store the collet in a safe location so it will not be damaged. If the collet is going to be stored for an extended period of time or where moisture is present, it should be coated with a thin layer of rust preventative oil.

Collet Installation



DANGER: To minimize the possibility of bodily injury or death, disconnect all electrical power prior to performing any maintenance or making adjustments to the equipment.

NOTE: Scribe marks on the stage shaft and housing along with the collet keyway indicator mark on the collet face must line up for collet removal and installation.

NOTE: It is important to know where the collet's keyway is located in reference to the face of the collet. The collet keyway must be lined up with the collet retention screw, but once the collet is threaded into the collet chuck, the only reference to the keyway is the collet face. To indicate the location of the keyway, it is recommended to either create a mark with permanent marker on the face of the collet or use the collet manufacturer's identification marks.

- Step 1: If you have not already done so, disable and remove power from the stage.
- Step 2: Clean the collet chuck taper and collet including the threads. Acetone or isopropyl alcohol may be used to clean the metal components. For optimum performance, the collet chuck taper and collet must be free of all dirt and debris.
- Step 3: Apply a small amount of general purpose, high viscosity grease or anti-sieze lubricant to the collet chuck taper (refer to [Section 4.2.1.](#)).
- Step 4: Verify that the collet chuck is in the open position. Guide the collet into the stage and thread it into the collet chuck by turning it clockwise until it bottoms out.
- Step 5: Unscrew the collet (one revolution maximum) by turning it counter-clockwise until the keyway reference mark on the face of the collet (see note above) is pointing to the scribes on the stage shaft and housing. All three reference marks must line up with each other before proceeding.
- Step 6: Tighten the collet retention screw using a 3 mm allen wrench through the access hole in the stage housing. The collet may need to be finely adjusted by hand (rotating clockwise and counter-clockwise) in order for the collet retention screw to fall into the keyway. Once the retention screw is in the collet keyway, the collet should not be able to rotate anymore.



WARNING: Ensure the collet retention screw is protruding into the keyway and not the collet threads. Driving the retention screw into the collet threads will affect system performance and possibly cause damage to the collet and stage.

- Step 7: Torque the collet retention screw hand tight. Do not over torque or the threads may be stripped out.
- Step 8: Install the cover screw into the stage housing and torque hand tight.
- Step 9: Insert the desired material workpiece into the collet. Actuate the collet to the closed position to verify the material workpiece is clamped in the collet. Adjust the collet depth and/or air pressure as required.
- Step 10: Restore power to the stage.

Chapter 3: Electrical Specifications and Installation



WARNING: Electrical installation must be performed by properly qualified personnel.

Electrical installation requirements will vary depending on product options. Installation instructions in this section are for CCS stages equipped with standard Aerotech motors intended for use with an Aerotech motion control system. Contact Aerotech for further information regarding products that are otherwise configured.

Aerotech motion control systems are adjusted at the factory for optimum performance. When the CCS is part of a complete Aerotech motion control system, setup usually involves connecting the CCS to the appropriate drive chassis with the cables provided. Labels on the system components usually indicate the appropriate connections.

If system level integration was purchased, an electrical drawing showing system interconnects has been supplied with the system (separate from this documentation).

The electrical wiring from the motor and encoder are integrated at the factory. Refer to the sections that follow for standard motor wiring and connector pinouts.



WARNING: Applications that require access to the CCS must be restricted to qualified and trained personnel. The system integrator or qualified installer is responsible for determining and meeting all safety and compliance requirements when they integrate the CCS into a completed system.



DANGER: Remove power before connecting or disconnecting electrical components or cables. Failure to do so could cause electric shock or damage to the equipment.

3.1. Motor and Feedback Connectors

Stages equipped with standard motors and encoders come from the factory completely wired and assembled.

NOTE: Refer to the other documentation accompanying your Aerotech equipment. Call your Aerotech representative if there are any questions on system configuration.

NOTE: If using standard Aerotech motors and cables, motor and encoder connection adjustments are not required.

The protective ground connection of the CCS provides motor frame ground protection only. Additional grounding and safety precautions are required for applications requiring access to the stage while it is energized. The System Integrator or qualified installer is responsible for determining and meeting all safety and compliance requirements necessary for the integration of this stage into the final application.



DANGER: Remove power before connecting or disconnecting electrical components or cables. Failure to do so could cause electric shock or damage to the equipment.



WARNING: The protective ground connection must be properly installed to minimize the possibility of electric shock.



CAUTION: The stage controller must provide over-current and over-speed protection. Failure to do so could cause electric shock or damage to the equipment..

Table 3-1: Motor Connector Pinout

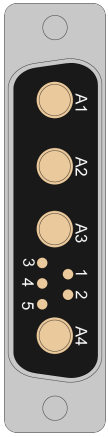
Pin	Description	Connector
A1	Motor Phase A	
A2	Motor Phase B	
A3	Motor Phase C	
1	Reserved	
2	Reserved	
3	Reserved	
4	Reserved	
5	Reserved	
A4	Frame Ground (motor protective ground)	

Mating Connector	Aerotech P/N	Third Party P/N
Backshell	ECK00656	Amphenol #17E-1726-2
Sockets [QTY. 4]	ECK00659	ITT Cannon #DM53744-6
Connector	ECK00657	ITT Cannon #DBM9W4SA197

Table 3-2: Feedback Connector Pinout

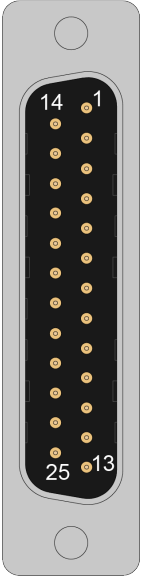
Pin	Description	Connector
1	Reserved	
2	Over-Temperature Thermistor sensor	
3	Encoder +5 V (internally connected to Pin 16)	
4	Reserved	
5	Hall Effect sensor, phase B	
6	Marker-N	
7	Marker	
8	Reserved	
9	Reserved	
10	Hall Effect sensor, phase A	
11	Hall Effect sensor, phase C	
12	Reserved	
13	Reserved	
14	Cosine	
15	Cosine-N	
16	Limit +5 V (internally connected to Pin 3)	
17	Sine	
18	Sine-N	
19	Reserved	
20	Limit Common (internally connected to Pin 21)	
21	Encoder Common (internally connected to Pin 20)	
22	Reserved	
23	Reserved	
24	Reserved	
25	Reserved	
Case	Signal shield connection (to case)	

Mating Connector	Aerotech P/N	Third Party P/N
Backshell	ECK00656	Amphenol #17E-1726-2
Connector	ECK00300	FCI DB25S064TLF

3.2. Motor and Feedback Wiring

All motor and controller manufacturers have their own designations for motor phases A/B/C and Hall signals A/B/C (refer to Section 3.5. for motor phasing). Shielded cables are required for the motor and feedback connections.

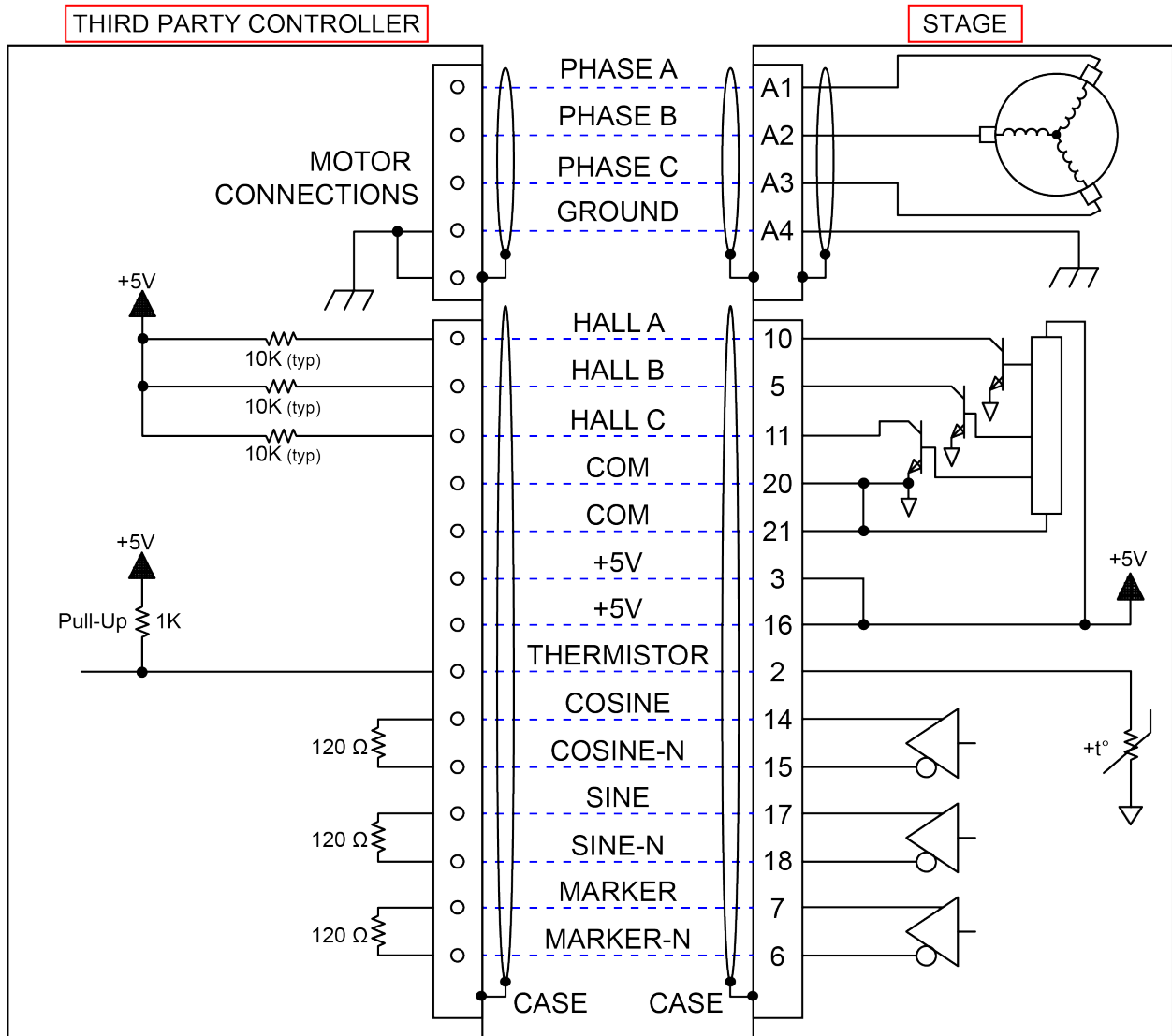

Figure 3-1: Motor and Feedback Wiring

3.3. Motor and Feedback Specifications

Table 3-3: Feedback Specifications

Hall-Effect Sensors Specifications	
Supply Voltage	5 V \pm 5%
Supply Current	50 mA
Output Type	Open Collector
Output Voltage	24 V max (pull up)
Output Current	5 mA (sinking)

Thermistor Specifications	
Polarity	Logic "0" (no fault)
	Logic "1" (over-temperature fault)
Cold Resistance	\sim 100 Ω
Hot Resistance	\sim 10 K
Note: 1K pull-up to +5V recommended.	

Encoder Specifications	
Supply Voltage	5 V \pm 5%
Supply Current	250 mA (typical)
Output Signals	Sinusoidal Type (Incremental Encoder): 1 V _{pk-pk} into 120 Ω Load (differential signals SIN+, SIN-, COS+, COS- are .5 V _{pk-pk} relative to ground.)
	Digital Output (Incremental Encoder): RS422/485 compatible

Table 3-4: Encoder Lines Per Revolution

	CCS130DR-160	CCS190DR-240-3C	CCS190DR-260-5C
Lines	3600 lines/rev	13,600 lines/rev	13,600 lines/rev
NOTE: Values show fundamental resolution of sine wave output from encoder. Values can change depending on the controller.			

Table 3-5: Maximum Speed (rpm)

	CCS130DR-160	CCS190DR-240-3C	CCS190DR-260-5C
Resolution Speed	3000 rpm	600 rpm	600 rpm

NOTE: The encoders used on all CCS series stages come standard with a MHz clock rate. Aerotech can provide slower or faster clock rates to match the controller being used. Consult Aerotech for more information.

Table 3-6: Rotary Motor Specifications for the CCS130DR-160

		S-76-35 (CCS130DR-160)
Performance Specifications (1,5)		
Winding Designation		-A
Stall Torque, Cont. (2)	N·m	0.48
Peak Torque (3)	N·m	1.92
Electrical Specifications (5)		
Winding Designation		-A
BEMF Const., line-line, Max	$V_{pk}/krpm$	29.1
Continuous Current, Stall (2)	A_{pk}	2.0
	A_{rms}	1.4
Peak Current, Stall (2)	A_{pk}	8.0
	A_{rms}	5.7
Torque Constant (4, 9)	$N·m/A_{pk}$	0.24
	$N·m/A_{rms}$	0.34
Motor Constant (2, 4)	$N·m/\sqrt{W}$	0.075
Resistance, 25°C, line-line	Ω	10.5
Inductance, line-line	mH	1.40
Maximum Bus Voltage	V_{DC}	340
Thermal Resistance	$^{\circ}C/W$	1.83
Number of Poles	--	14
1. Performance is dependent upon heat sink configuration, system cooling conditions, and ambient temperature 2. Values shown @ 75°C rise above a 25 °C ambient temperature, with housed motor mounted to a 250 mm x 250 mm x 6 mm aluminum heat sink 3. Peak force assumes correct rms current; consult Aerotech. 4. Torque constant and motor constant specified at stall 5. All performance and electrical specifications $\pm 10\%$ 6. Specifications given are for the motor only. When integrated into a housing with bearings additional losses should be considered. 7. Maximum winding temperature is 100 °C (thermistor trips at 100 °C) 8. Ambient operating temperature range 0 °C - 25 °C; consult Aerotech for performance in elevated ambient temperatures 9. All Aerotech amplifiers are rated A_{pk} ; use torque constant in $N·m/A_{pk}$ when sizing		

Table 3-7: Rotary Motor Specifications for the CCS190DR-240-3C and CCS190DR-260-5C

		S-130-39 (CCS190DR-240-3C)	S-130-60 (CCS190DR-260-5C)
Performance Specifications (1,5)			
Winding Designation		-A	-A
Stall Torque, Cont. (2)	N·m	2.85	5.06
Peak Torque (3)	N·m	11.39	20.22
Electrical Specifications (5)			
Winding Designation		-A	-A
BEMF Const., line-line, Max	$V_{pk}/krpm$	90.7	180.0
Continuous Current, Stall (2)	A_{pk}	3.8	3.4
	A_{rms}	2.7	2.4
Peak Current, Stall (2)	A_{pk}	15.2	13.6
	A_{rms}	10.7	9.6
Torque Constant (4, 9)	$N·m/A_{pk}$	0.75	1.49
	$N·m/A_{rms}$	1.06	2.10
Motor Constant (2, 4)	$N·m/\sqrt{W}$	0.321	0.539
Resistance, 25°C, line-line	Ω	5.6	7.8
Inductance, line-line	mH	1.70	1.80
Maximum Bus Voltage	V_{DC}	340	340
Thermal Resistance	$^{\circ}C/W$	0.95	0.85
Number of Poles	--	18	18
<p>1. Performance is dependent upon heat sink configuration, system cooling conditions, and ambient temperature</p> <p>2. Values shown @ 75°C rise above a 25 °C ambient temperature, with housed motor mounted to a 330 mm x 330 mm x 13 mm aluminum heat sink</p> <p>3. Peak force assumes correct rms current; consult Aerotech.</p> <p>4. Torque constant and motor constant specified at stall</p> <p>5. All performance and electrical specifications $\pm 10\%$</p> <p>6. Specifications given are for the motor only. When integrated into a housing with bearings additional losses should be considered.</p> <p>7. Maximum winding temperature is 100 °C (thermistor trips at 100 °C)</p> <p>8. Ambient operating temperature range 0 °C - 25 °C; consult Aerotech for performance in elevated ambient temperatures</p> <p>9. All Aerotech amplifiers are rated A_{pk}; use torque constant in $N·m/A_{pk}$ when sizing</p>			

3.4. Limits, Marker, and Machine Direction

Aerotech stages are configured to have positive and negative "machine" directions. The machine direction defines the phasing of the feedback and motor signals and is dictated by the stage wiring (refer to [Section 3.5](#) for Motor and Feedback phasing information). Programming direction of a stage is set by the controller that is used to move the stage. Programming direction is typically selectable in the controller, while machine direction is hardwired in the stage. [Figure 3-2](#) shows the machine direction of CCS stages.

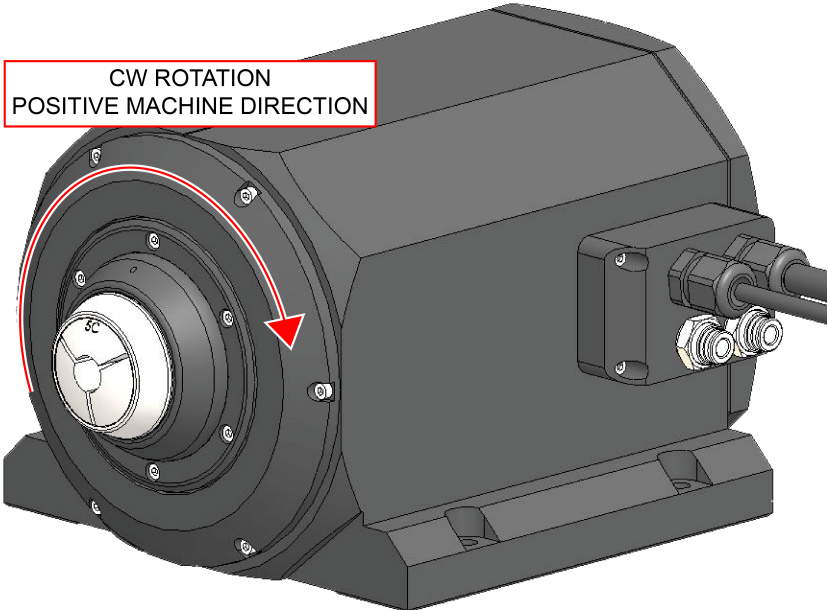
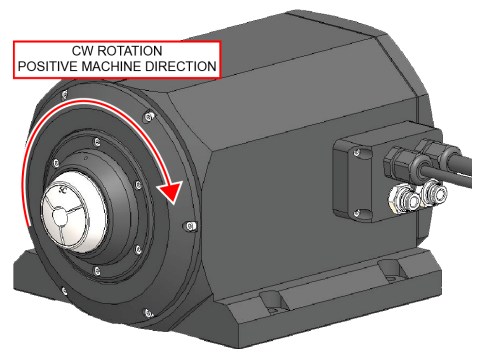
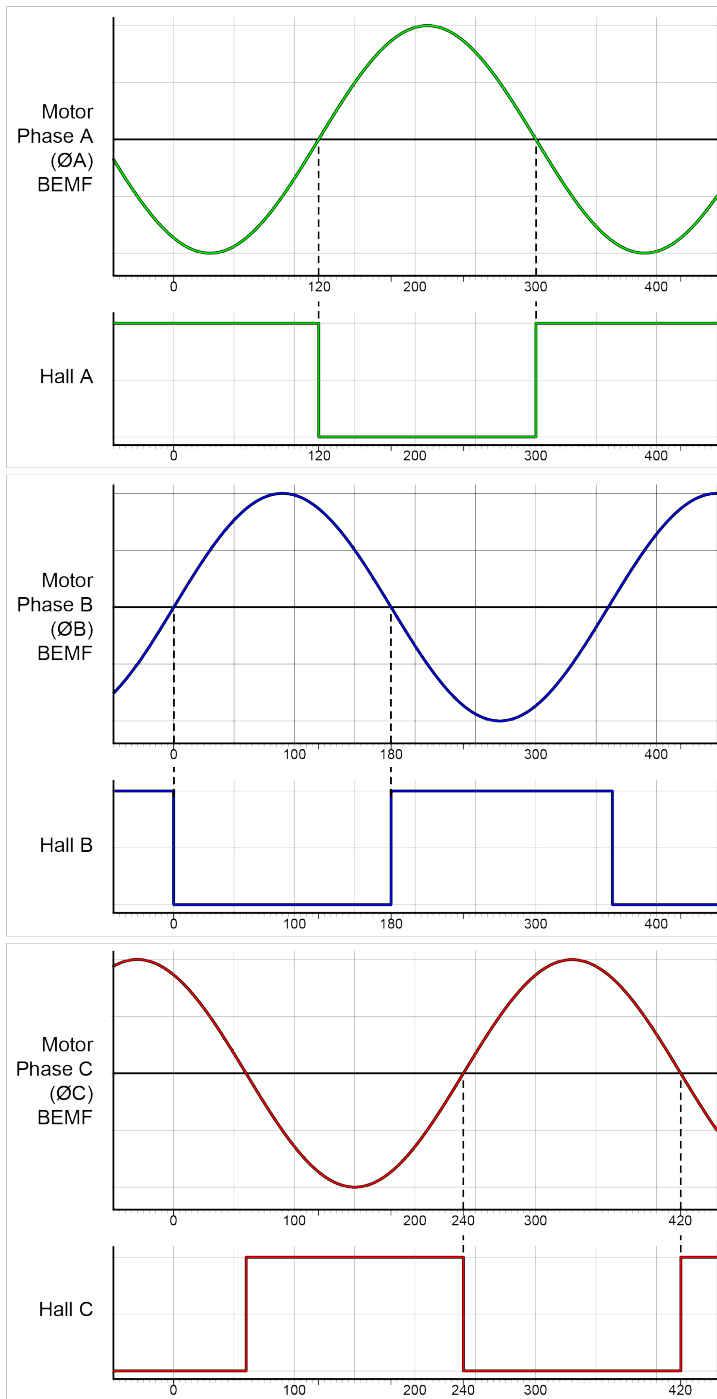

Figure 3-2: Machine Direction

3.5. Motor and Feedback Phasing

Motor phase voltage is measured relative to the virtual wye common point.



Positive MOVE (Clockwise) →

Figure 3-3: Hall Phasing

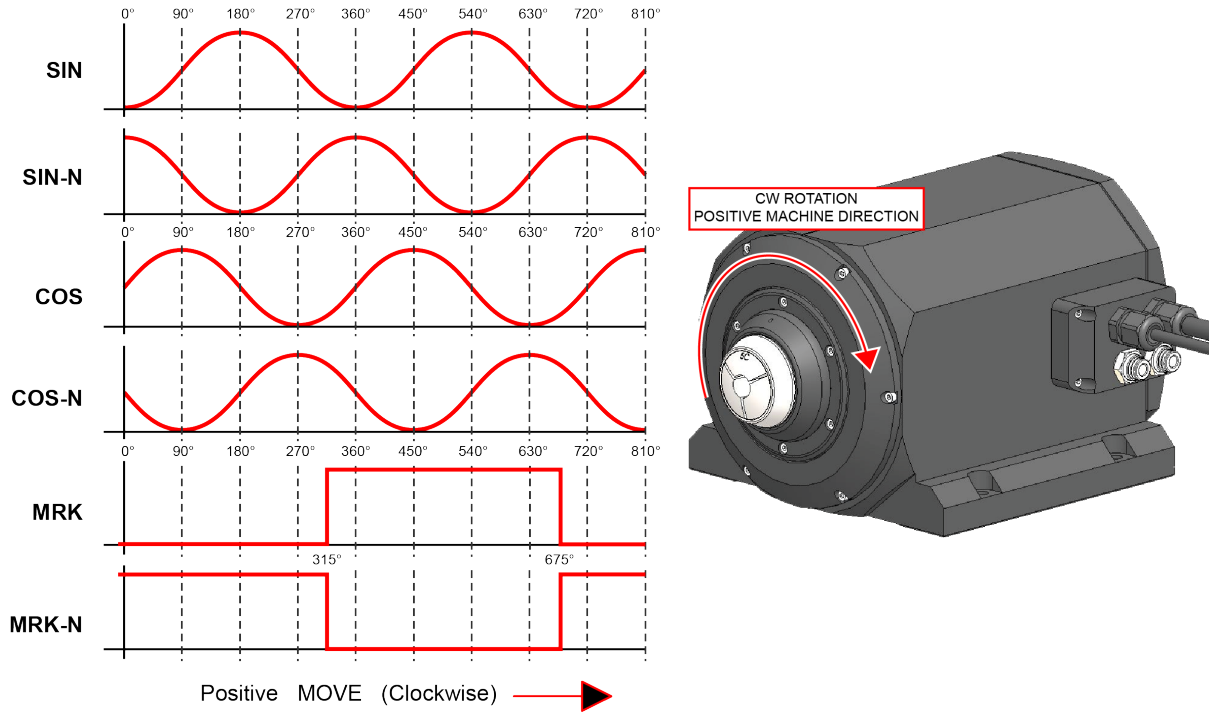

Figure 3-4: Analog Encoder Phasing Reference Diagram

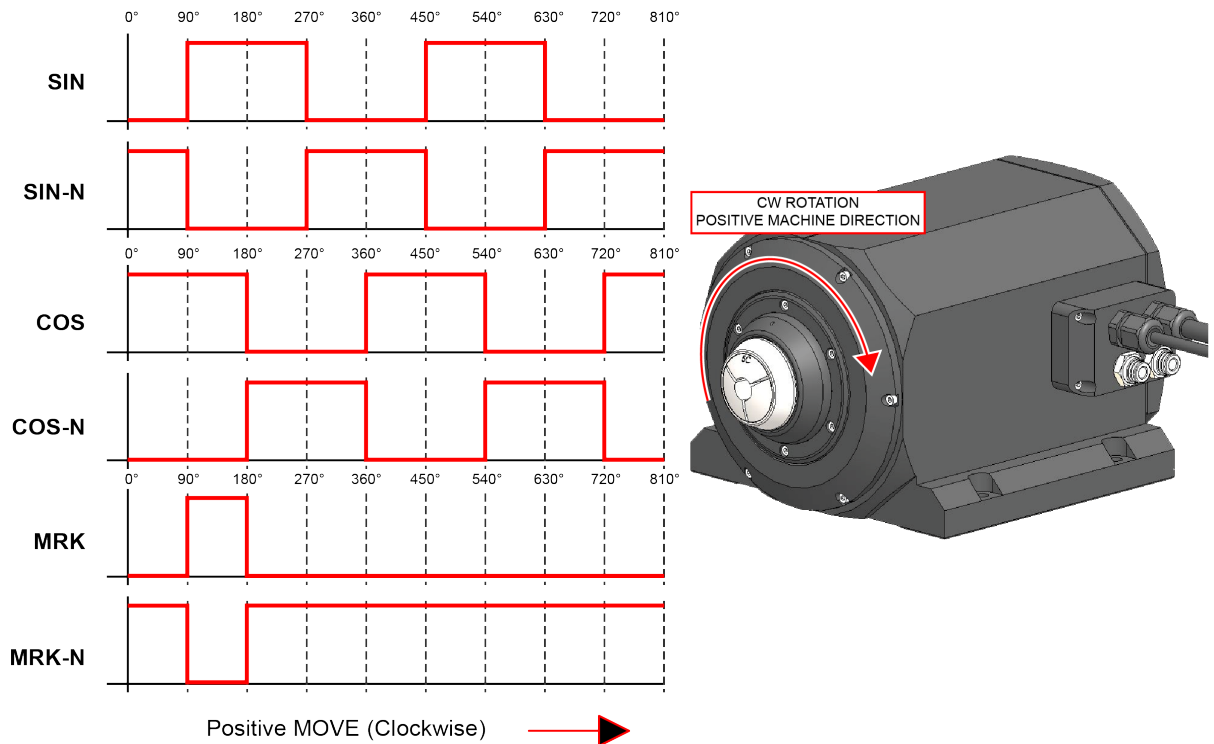

Figure 3-5: Encoder Phasing Reference Diagram (Standard)

This page intentionally left blank.

Chapter 4: Maintenance

The CCS series stages are designed to require minimum maintenance. There are some items that may require preventative maintenance during the lifetime of the stage. This chapter will cover information about component maintenance and replacement, intervals between lubrication, detail the lubrication and inspection process, and specify recommended lubricants and cleaning solvents.



DANGER: To minimize the possibility of bodily injury or death, disconnect all electrical power prior to performing any maintenance or making adjustments to the equipment.



WARNING: Failure to follow the maintenance procedures outlined in this section will result in voiding stage warranty.

4.1. Service and Inspection Schedule

A frequent inspection and cleaning interval of the CCS series stages is recommended until a trend develops for the application. The inspection and cleaning interval depends on application conditions such as duty cycle, speed, and environment. As part of the inspection process, the stage, cables, collet/collet chuck, and seals should be examined for wear, damage, and excessive air or water leakage. The bearings, motor, and encoder do not require any preventative maintenance. Once the stage condition has been assessed, the inspector should:

- Repair any damage before resuming operation of the stage
- Re-tighten loose connectors
- Replace or repair damaged cables
- Remove collet and inspect, clean, and relubricate collet and collet chuck
- Clean the stage and cables if needed

In general, repair and/or replacement of damaged or malfunctioning components by Aerotech field service personnel is not possible. Repair typically requires that the unit be returned to the factory. Please contact Aerotech Global Technical Support for more information.

4.2. Cleaning and Lubrication

Cleaning

Before using a cleaning solvent on any part of the CCS, blow away small particles and dust with nitrogen or, less preferably, clean, dry, compressed air.

Any metal surface on the stage can be cleaned with either acetone or isopropyl alcohol. Cleaning solvents, especially acetone, should not be used on any rubber components (o-rings and seals). If rubber components require cleaning, nitrogen or clean, dry, oil-less compressed air can be used to blow them off and a lint-free cloth or rag can be used to remove excess grease, oil, or other contaminants.



WARNING: Make sure that all solvent has completely evaporated before attempting to move the stage.



WARNING: Acetone should never be used to clean the o-rings or seals.

Lubrication

O-rings and collet piston seals should be lubricated with Parker O-Lube lubricant or an equivalent o-ring lubricant. The collet chuck taper should be lubricated with a general purpose, high viscosity grease or anti-seize lubricant (refer to [Section 4.2.1.](#)).

If the application process uses only a small portion of travel for most of the duty cycle, periodically drive the stage through full travel to redistribute the lubrication in the bearings.

4.2.1. Collet & Collet Chuck Lubrication and Cleaning



WARNING: Failure to lubricate and clean the collet interface surfaces will cause premature failure and wear that may void the warranty.

For the collet chuck and collet to operate properly, preventative maintenance and regular cleaning is required.

Before inserting any collet into the chuck, clean the chuck taper and the collet with acetone or isopropyl alcohol and a lint-free cloth. If required, nitrogen or clean, dry, oil-less compressed air can be used to clean out the collet grooves. Inspect the collet and the chuck interface surfaces to be sure no wear marks are present. If wear or fret marks (copper colored oxide marks) are present, the taper can be lightly polished with a fine-grit crocus cloth. The goal is to clean the surface of the taper and not to remove an excessive amount of material. If the wear marks are large, or excessive polishing is required to remove these marks, the collet chuck and collet may need to be replaced. Contact Aerotech Technical Support for more information. Wear and fretting can be prevented with proper lubrication and maintenance intervals.

After inspection and cleaning, grease the collet chuck taper and collet taper with a small amount of lubricant. Then, install the collet into the collet chuck (refer to [Section 2.8.](#)). Aerotech recommends using the lubricants listed in [Table 4-1.](#)

Table 4-1: Recommended Lubricants

Vender	Product	Item #	Description
Henkel Technologies	Loctite	80209	Silver Grade Anti-Seize
Henkel Technologies	Loctite	51168	Food Grade Anti-Seize
Jet Lube	White Knight	16404	Food Grade Anti-Seize

Lubricant inspection and replenishment depend on application conditions such as collet chuck duty cycle, clamping force (air pressure), and the machining environment. An inspection interval of once every 8 operational hours is recommended until a trend develops for the application. Longer or shorter intervals may be required to maintain a film of lubricant on the collet taper. The collet and chuck should also be cleaned and relubricated after sitting for an extended period of time without operation. If the lubrication sits for long periods of time, it can become dry and lose its lubrication properties. Insufficient lubrication will lead to wear, fretting corrosion, and sticking or lock-up of the collet closer. If this occurs, the machine should be immediately stopped and the collet and collet chuck cleaned and relubricated. It is also recommended that the collet and chuck interface surfaces be cleaned, inspected, and relubricated every time the collet is removed.

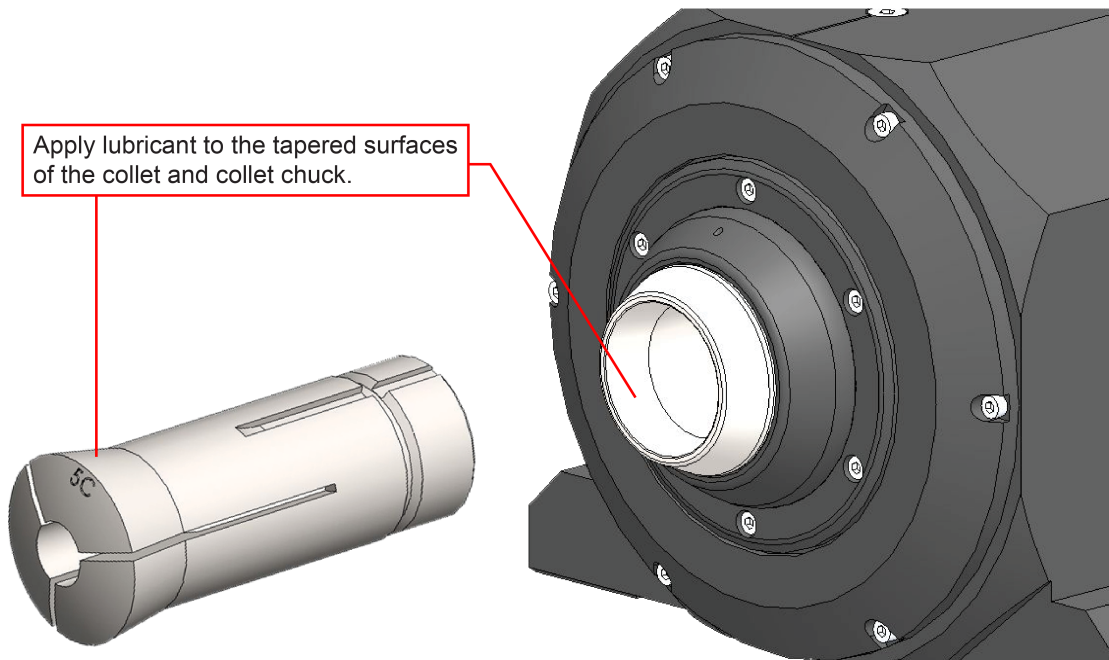

Figure 4-1: Collet and Collet Chuck Tapered Surfaces

4.3. Seal Replacement

4.3.1. Piston Seal Change Procedure

The collet chuck and actuation mechanism on the CCS series stages are equipped with o-ring seals that are designed to last many collet chuck (open/close) cycles. However, due to regular wear, the seals may require replacement during the lifetime of the product. If trouble with the piston seals is suspected, it is recommended that you contact Aerotech Technical Support. The seals should only be replaced by a qualified Aerotech technician.

4.3.2. Ringseal O-Ring Replacement (CCS130DR-160 with -WCUT option only)

During the lifetime of the stage, it may be necessary to change the ringseal o-rings. Contact Aerotech to obtain proper replacement seals. The ringseal screws into the center of the shaft from the front of the stage. Use the steps that follow to replace the o-ring.



DANGER: To minimize the possibility of bodily injury or death, disconnect all electrical power prior to performing any maintenance or making adjustments to the equipment.



Figure 4-2: Typical Ringseal

Step 1: Remove power to the stage.

Step 2: Remove collet (See [Section 2.8.](#)).

Step 3: With the collet removed, the ringseal will now be exposed. Using a 4 mm allen key or [WIHA Tool #54040] unscrew the ringseal from the shaft.

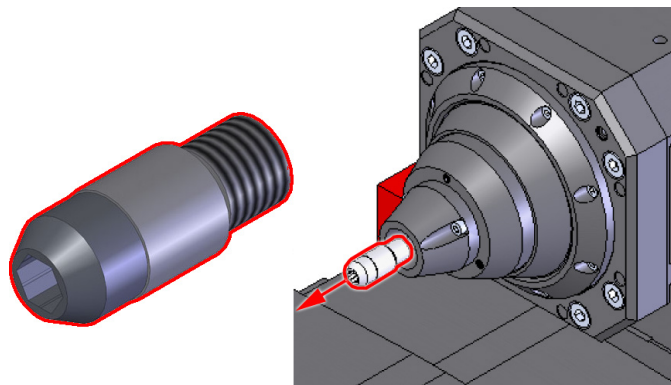

Figure 4-3: Typical Ringseal Removal

- Step 4: Remove the o-ring ringseal (shown in [Figure 4-4](#)). The replacement o-ring ringseal should be properly lubricated. The shaft o-ring is a static seal and provides secondary protection against leaks. This seal does not need to be replaced unless required. A long pick or thin screwdriver will be necessary to remove the shaft o-ring.
- Step 5: Wrap the ringseal threads with Teflon thread seal tape [PTFE tape] in preparation for installation.
- Step 6: Re-insert the ringseal into the inner collet housing and tighten into position.
- Step 7: Re-insert the collet.

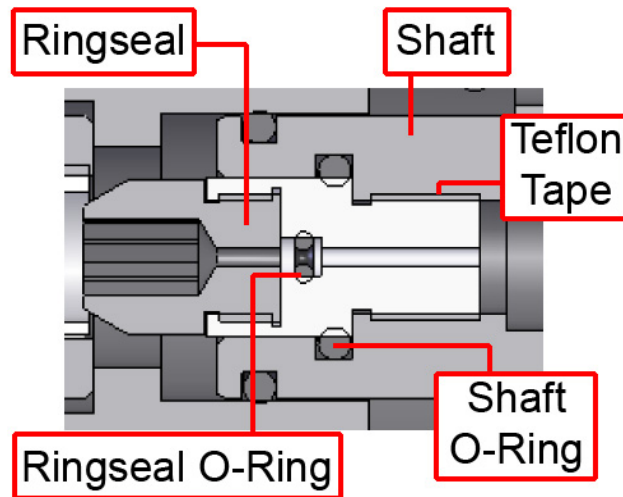

Figure 4-4: Cross-section View of Ringseal Showing O-Rings

4.3.3. Wet Cut Rotary Union Seal Replacement (CCS130DR-160 with -WCUT option only)

The rotary seal in the wet cut rotary union requires periodic replacement. Contact Aerotech for obtaining appropriate replacement seals. Figure 4-5 shows a cross section of the rotary union assembly.



DANGER: The wet cut rotary union seal should be replaced and relubricated at a minimum of every 1000 hours of stage operation.

For heavy use or three shift operation: this corresponds to replacement every month.
For lighter use or single shift operation: this corresponds to replacement every three months.



WARNING: Failure to follow the maintenance procedures outlined in this section will result in voiding stage warranty.



DANGER: To minimize the possibility of bodily injury or death, disconnect all electrical power prior to performing any maintenance or making adjustments to the equipment.

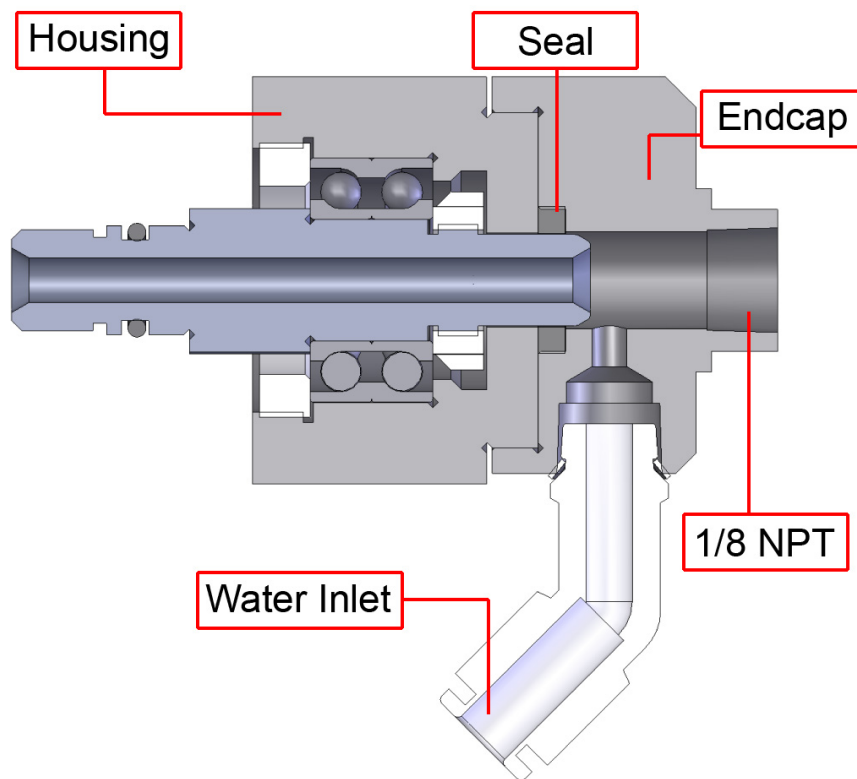

Figure 4-5: Cross-Section View of Wet Cut Rotary Union

Step 1: Remove power to the stage.

Step 2: Purge water from inside stage. Care should be taken when doing this to prevent large amounts of water from being deposited on stage.

Step 3: To access the rotary union seal, remove [QTY-4] M3 end cap mounting screws from the rear of the assembly and carefully pull the end cap off of the housing (refer to [Figure 4-6](#)).

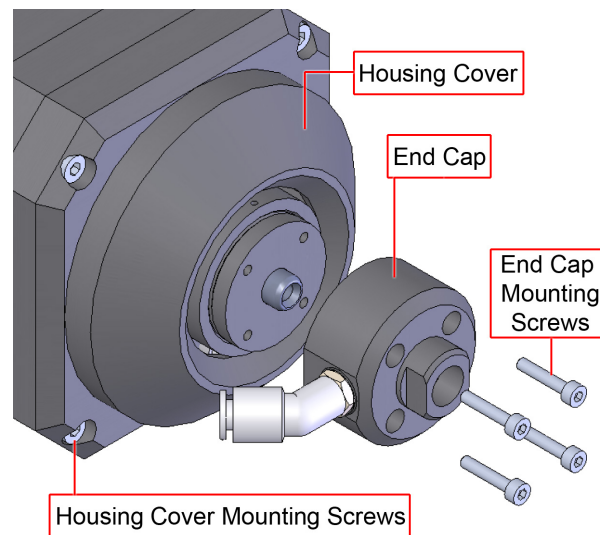

Figure 4-6: Rear Carriage Cover w/ Wet Cut Rotary Union

Step 4: The rotary seal and rotary union shaft will now be exposed. Pry the rotary seal from end cap using care not to damage the sealing surfaces (see [Figure 4-7](#)).



Figure 4-7: Seal Location

Step 5: Inspect the shaft and seal surface for scratches or nicks (refer to [Figure 4-8](#)). Small wear marks are normal. If the shaft is undamaged, clean both the shaft and seal end cap surfaces with a lint-free rag and isopropyl alcohol. If the shaft is scratched (you can feel it with your fingernail), contact Aerotech Technical Support.

If advised to remove the rotary union, see [Section 4.4](#) for instructions.

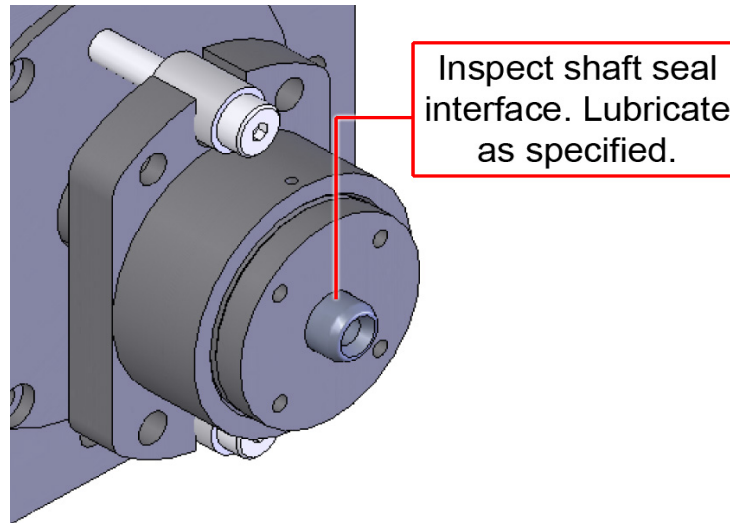

Figure 4-8: Wet Cut Rotary Union Shaft Inspection

- Step 6: Lubricate the new seal with a generous amount of Parker O-Lube and press it uniformly into its housing in the end cap.
- Step 7: Apply Parker O-Lube to the exposed end of the rotary union shaft as shown in [Figure 4-8](#).
- Step 8: Pilot the end cap back onto housing sub-assembly by using the rotary union shaft and housing. Use care when aligning the end cap so that damage does not occur to the newly installed seal.
- Step 9: Tighten the end cap screws and reconnect water supply.
- Step 10: Leak test stage prior to restoring stage power.

4.4. Wet Cut Rotary Union Removal

If the rotary union shaft becomes scratched or damaged, the rotary union must be replaced in order to properly seal the system (refer to [Figure 4-9](#) for a view of the rotary union assembly).



DANGER: To minimize the possibility of bodily injury or death, disconnect all electrical power prior to performing any maintenance or making adjustments to the equipment.

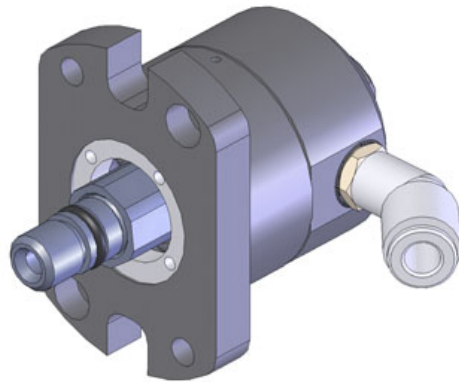

Figure 4-9: Wet Cut Rotary Union

- Step 1: Remove power to the stage.
- Step 2: Purge water from inside stage. Care should be taken when doing this to prevent large amounts of water from being deposited on stage.
- Step 3: Remove [QTY. 4] M3 end cap mounting screws from the rear of the assembly and carefully pull the end cap off of the housing. Also remove [QTY. 4] M5 rear housing cover screws along with cover (see [Figure 4-6](#)).
- Step 4: Remove the shoulder bolts and bushings (see [Figure 4-10](#)).

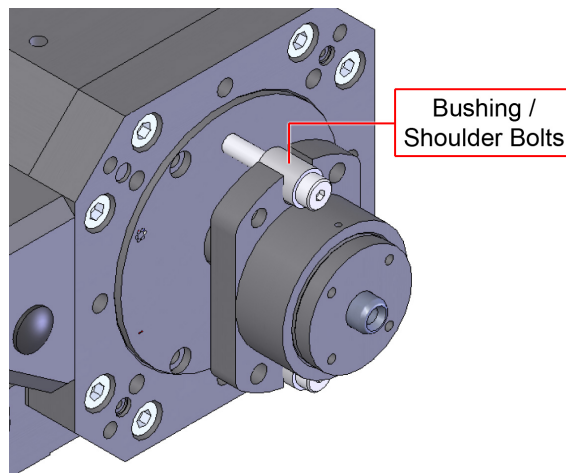

Figure 4-10: Housing Assembly Showing Rotary Union

Step 5: Using a 14 mm wrench on the rotary union nut and a 14 mm wrench on the CCS shaft. Remove the wet cut rotary union from the CCS shaft (see [Figure 4-11](#)).

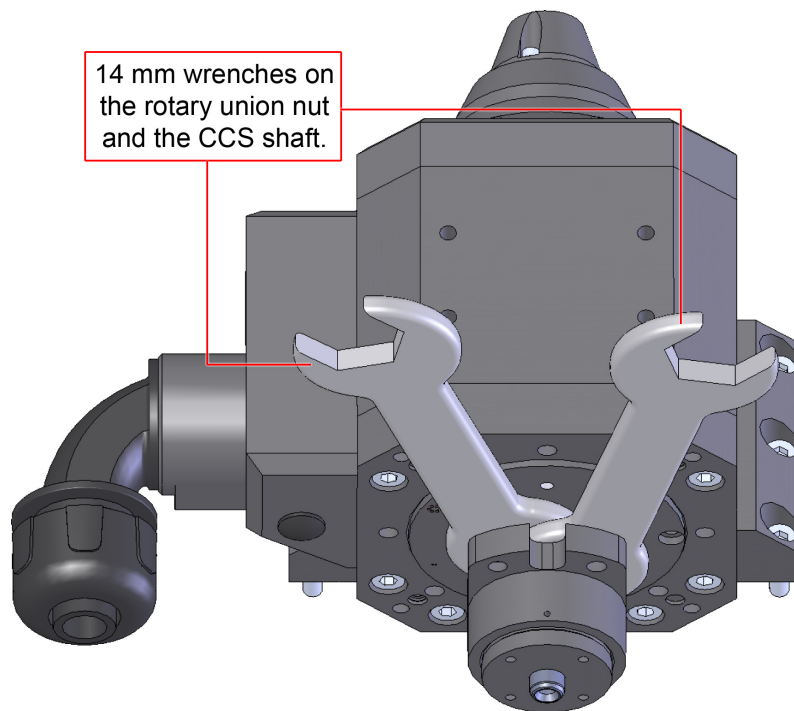

Figure 4-11: Rotary Union Removal

Step 6: Install a new rotary union assembly by attaching it to the rear of the CCS shaft. Tighten to 10 ft·lbs.

Step 7: Reinstall shoulder bolts and bushings.

Step 8: Reattach cover and end cap.

Step 9: Leak test stage prior to restoring stage power.

4.5. Wet Cut Maintenance (CCS190DR-240-3C and CCS190DR-260-5C)

The CCS190DR-240-3C and CCS190DR-260-5C stages were designed to accept and operate with customer supplied wet-cut accessories. No additional maintenance is required when the stage is used under wet-cut conditions. However, the stage may need to be inspected on shorter intervals for possible water leakage and contamination.

If wet-cut fluid leaks into the aperture, the stage should be stopped, cleaned, inspected, and relubricated before continuing operation. Drains and seals have been strategically placed in the stage to remove fluid from internal components of the stage; however, residual fluid can remain in the stage and migrate to bearings, the encoder, and other critical components if not properly cleaned. Fluid contamination in these components could lead to premature failure of the stage. To fully clean the stage after a wet-cut leak, do the steps that follow:



DANGER: To minimize the possibility of bodily injury or death, disconnect all electrical power prior to performing any maintenance or making adjustments to the equipment.



WARNING: Compressed air and/or nitrogen should not be used to dry any part of the stage. Compressed air and nitrogen could force fluid past stage seals and cause damage to the stage. Always use a lint-free cloth or rag and avoid pushing fluid further into the stage internals. Always try to wipe starting from the inside of the stage to the outside. This motion will help push fluid out of the stage internals.

- Step 1: Disable and remove power from the stage.
- Step 2: Thoroughly wipe the exterior of the stage, stage cables, and connectors to remove all fluid that may have gotten on them. The stage cables and connectors are not water resistant. All fluid must be removed to safely operate the stage.
- Step 3: Remove the collet (refer to [Section 2.8](#)).
- Step 4: Run a lint-free cloth or rag through the entire aperture. The collet chuck and aperture should be free of any residual fluids. Do not use compressed air or nitrogen to dry aperture.
- Step 5: Remove and dry the rear cover and/or any wet-cut accessories on the rear of the stage. The rear cover can be removed by using a 2 mm allen wrench to loosen and remove the [QTY. 6] fasteners holding it on. Store the rear cover and fasteners together, in a safe location for later re-assembly.

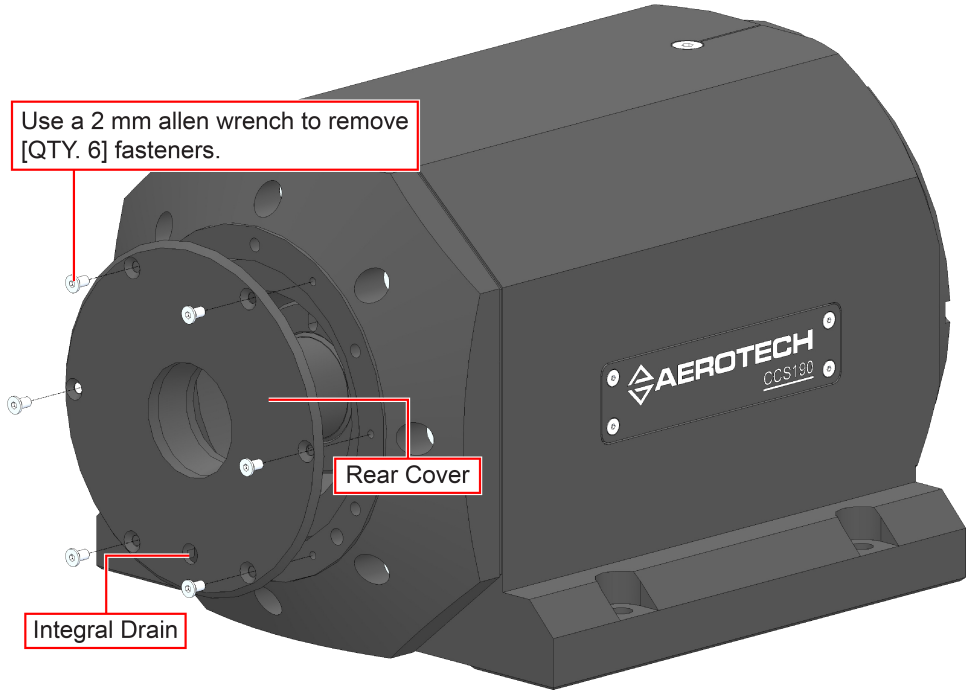

Figure 4-12: Rear Cover Removal

Step 6: With the rear cover removed, the collet closer piston and piston housing can be wiped out to remove any fluid that remains from the wet-cut leak. There may be o-ring lubricant present on some of the surfaces. The lubrication should be left if possible, but removing it will not cause harm to the system's operation.

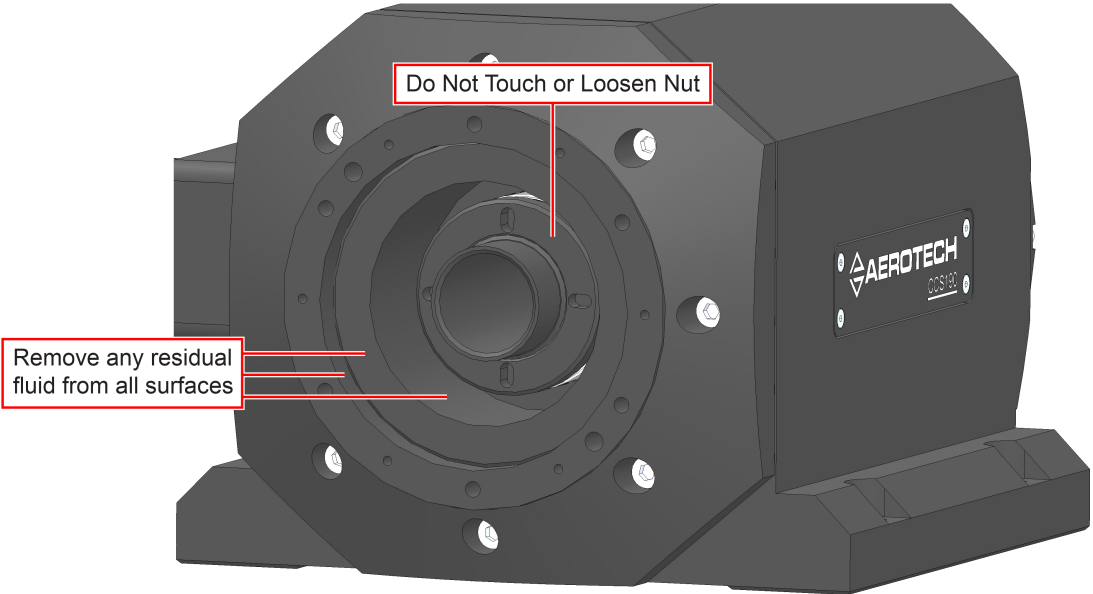

Figure 4-13: Collet-Chuck Piston and Piston Housing Cleaning

Step 7: Remove the front cover from the front of the stage. The front cover is attached with [QTY. 6] fasteners that can be removed with a 2.5 mm allen wrench. Store the front cover and the fasteners in a safe location for later re-assembly.

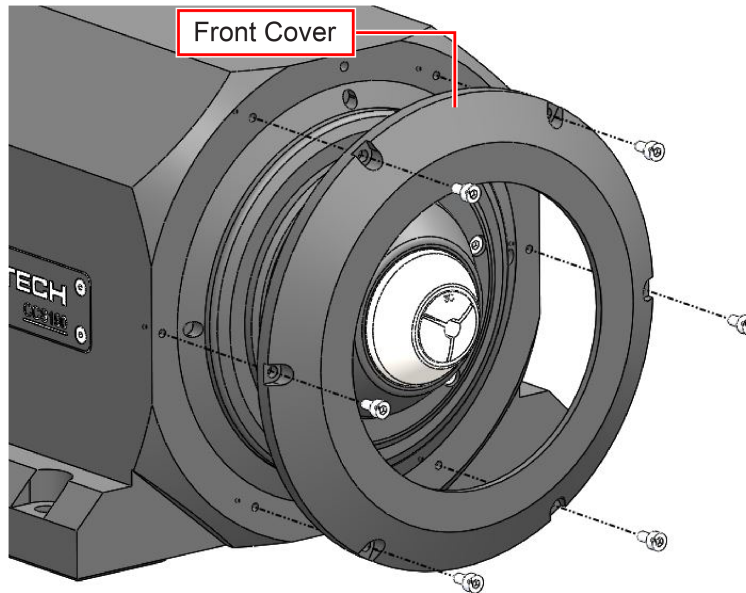

Figure 4-14: Front Cover and Labyrinth Seal Removal

Step 8: Thoroughly dry the front cover with a lint-free cloth or rag. Also dry the entire front of the stage that has been exposed by removing the cover. Do not use compressed air or nitrogen to dry the stage.

Step 9: Add more water-compatible grease when needed (AeroShell Grease #7) to the labyrinth seal through the grease fitting (see [Figure 4-15](#)), using a THK MG-70 grease gun with a Type-N adapter or equivalent. The grease nipple on the front face supplies the grease to the labyrinth seal, which acts as a fluid barrier during stage operation.

NOTE: Do not add excessive amounts of grease to the labyrinth seal.

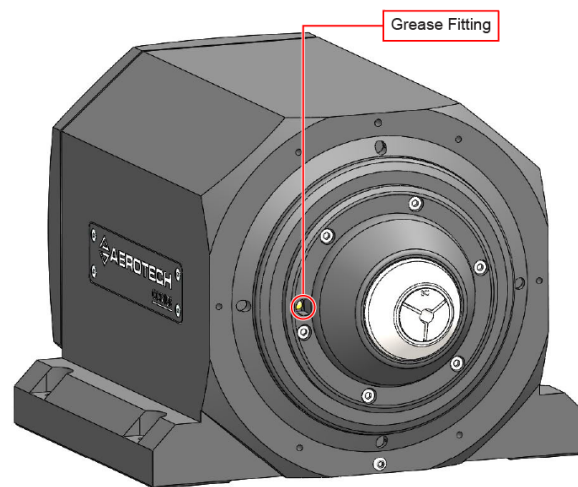

Figure 4-15: Front of Stage Cleaning

NOTE: Use Loctite 242 or an equivalent medium strength threadlocker on all the fasteners to prevent loosening.

Step 10: Reinstall the front cover by reversing the disassembly procedure in Step 7. Orient the front cover such that the integral drain slot is located at the lowest point of the stage. Rotate the stage shaft by hand to verify the front cover does not rub. Adjust if necessary. Tighten the fasteners to 1.0 N·m (8.7 in·lb).

NOTE: Front cover orientation is dependent on stage mounting orientation. [Figure 4-16](#) shows a horizontal axis of rotation, mounting feet down stage and front cover orientation. Adjust as necessary to each application.

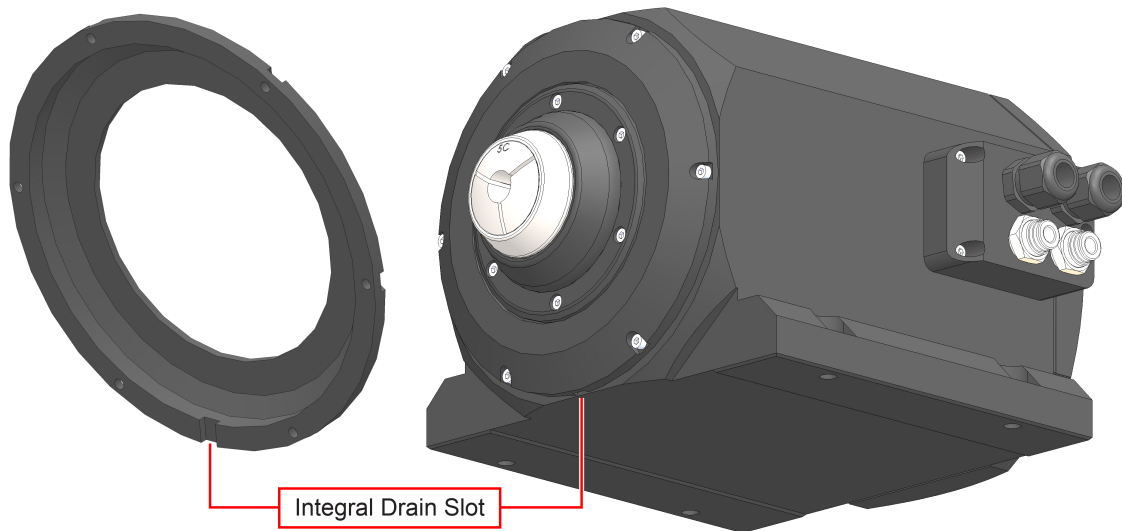

Figure 4-16: Front Cover Installation

Step 11: Reinstall the rear cover and/or wet-cut accessories by reversing the disassembly procedure in Step 5. Orient the rear cover such that the integral drain is located at the lowest point of the stage. Tighten the fasteners to 1.0 N·m (8.7 in·lb).

Step 12: Reinstall the collet. Follow all of the steps in [Section 2.8](#), including cleaning, inspection, and relubrication.

Step 13: Reconnect stage cables and restore power to the stage.

4.6. Troubleshooting

This section provides some information regarding typical problems.

Symptom	Possible Cause and Solution
Stage will not move	Controller trap or fault (refer to the Controller documentation).
Stage moves uncontrollably	<ul style="list-style-type: none"> Encoder (sine and cosine) signal connections (refer to Chapter 3 and Controller documentation). Motor Connections (refer to Chapter 3 and the Controller documentation).
Stage oscillates or squeals	<ul style="list-style-type: none"> Gains misadjusted (refer to the Controller documentation). Encoder signals (refer to the Controller documentation).
Collet Chuck will not close	<ul style="list-style-type: none"> Insufficient air pressure supplied to the stage. Make sure there are no blockages in the supply line and the pressure is high enough (refer to Section 2.5). Air supplied to both "Collet Chuck Open" and "Collet Chuck Closed" inputs. Supply to only one input at a time Collet not threaded in all the way. Follow procedures in Section 2.8. to ensure collet is installed properly
Collet Chuck will not open	<ul style="list-style-type: none"> Insufficient air pressure supplied to the stage. Make sure there are no blockages in the supply line and the pressure is high enough (refer to Section 2.5). Air supplied to both "Collet Chuck Open" and "Collet Chuck Closed" inputs. Supply to only one input at a time The collet has not been lubricated properly or the lubrication needs to be replenished (refer to Section 4.2.1).

This page intentionally left blank.

Appendix A: Warranty and Field Service

Aerotech, Inc. warrants its products to be free from harmful defects caused by faulty materials or poor workmanship for a minimum period of one year from date of shipment from Aerotech. Aerotech's liability is limited to replacing, repairing or issuing credit, at its option, for any products that are returned by the original purchaser during the warranty period. Aerotech makes no warranty that its products are fit for the use or purpose to which they may be put by the buyer, whether or not such use or purpose has been disclosed to Aerotech in specifications or drawings previously or subsequently provided, or whether or not Aerotech's products are specifically designed and/or manufactured for buyer's use or purpose. Aerotech's liability on any claim for loss or damage arising out of the sale, resale, or use of any of its products shall in no event exceed the selling price of the unit.

THE EXPRESS WARRANTY SET FORTH HEREIN IS IN LIEU OF AND EXCLUDES ALL OTHER WARRANTIES, EXPRESSED OR IMPLIED, BY OPERATION OF LAW OR OTHERWISE. IN NO EVENT SHALL AEROTECH BE LIABLE FOR CONSEQUENTIAL OR SPECIAL DAMAGES.

Return Products Procedure

Claims for shipment damage (evident or concealed) must be filed with the carrier by the buyer. Aerotech must be notified within thirty (30) days of shipment of incorrect material. No product may be returned, whether in warranty or out of warranty, without first obtaining approval from Aerotech. No credit will be given nor repairs made for products returned without such approval. A "Return Materials Authorization (RMA)" number must accompany any returned product(s). The RMA number may be obtained by calling an Aerotech service center or by submitting the appropriate request available on our website (www.aerotech.com). Products must be returned, prepaid, to an Aerotech service center (no C.O.D. or Collect Freight accepted). The status of any product returned later than thirty (30) days after the issuance of a return authorization number will be subject to review.

Visit <https://www.aerotech.com/global-technical-support.aspx> for the location of your nearest Aerotech Service center.

Returned Product Warranty Determination

After Aerotech's examination, warranty or out-of-warranty status will be determined. If upon Aerotech's examination a warranted defect exists, then the product(s) will be repaired at no charge and shipped, prepaid, back to the buyer. If the buyer desires an expedited method of return, the product(s) will be shipped collect. Warranty repairs do not extend the original warranty period.

Fixed Fee Repairs - Products having fixed-fee pricing will require a valid purchase order or credit card particulars before any service work can begin.

All Other Repairs - After Aerotech's evaluation, the buyer shall be notified of the repair cost. At such time the buyer must issue a valid purchase order to cover the cost of the repair and freight, or authorize the product(s) to be shipped back as is, at the buyer's expense. Failure to obtain a purchase order number or approval within thirty (30) days of notification will result in the product(s) being returned as is, at the buyer's expense.

Repair work is warranted for ninety (90) days from date of shipment. Replacement components are warranted for one year from date of shipment.

Rush Service

At times, the buyer may desire to expedite a repair. Regardless of warranty or out-of-warranty status, the buyer must issue a valid purchase order to cover the added rush service cost. Rush service is subject to Aerotech's approval.

On-site Warranty Repair

If an Aerotech product cannot be made functional by telephone assistance or by sending and having the customer install replacement parts, and cannot be returned to the Aerotech service center for repair, and if Aerotech determines the problem could be warranty-related, then the following policy applies:

Aerotech will provide an on-site Field Service Representative in a reasonable amount of time, provided that the customer issues a valid purchase order to Aerotech covering all transportation and subsistence costs. For warranty field repairs, the customer will not be charged for the cost of labor and material. If service is rendered at times other than normal work periods, then special rates apply.

If during the on-site repair it is determined the problem is not warranty related, then the terms and conditions stated in the following "On-Site Non-Warranty Repair" section apply.

On-site Non-Warranty Repair

If any Aerotech product cannot be made functional by telephone assistance or purchased replacement parts, and cannot be returned to the Aerotech service center for repair, then the following field service policy applies:

Aerotech will provide an on-site Field Service Representative in a reasonable amount of time, provided that the customer issues a valid purchase order to Aerotech covering all transportation and subsistence costs and the prevailing labor cost, including travel time, necessary to complete the repair.

Service Locations

<http://www.aerotech.com/contact-sales.aspx?mapState=showMap>

USA, CANADA, MEXICO	CHINA	GERMANY
Aerotech, Inc. Global Headquarters Phone: +1-412-967-6440 Fax: +1-412-967-6870	Aerotech China Full-Service Subsidiary Phone: +86 (21) 5508 6731	Aerotech Germany Full-Service Subsidiary Phone: +49 (0)911 967 9370 Fax: +49 (0)911 967 93720
TAIWAN	UNITED KINGDOM	
Aerotech Taiwan Full-Service Subsidiary Phone: +886 (0)2 8751 6690	Aerotech United Kingdom Full-Service Subsidiary Phone: +44 (0)1256 855055 Fax: +44 (0)1256 855649	

Have your customer order number ready before calling.

Appendix B: Revision History

Revision	General Information
1.04.00	Update grease from Castrol Aeroplex AI to AeroShell Grease #7 (Section 4.2.)
1.03.00	Update air filtration specification from 0.25 microns to 1 micron (Section 2.5.)
1.02.00	General revision / Product update
1.01.00	New drain design
1.00.00	New manual

This page intentionally left blank.

Index

	2		G	
			Global Technical Support	2
2006/42/EC		7	H	
	A		Hall-Effect Sensors Specifications	32
air			Humidity	11
compressed		20	I	
nitrogen		20	inspection schedule	39
Air Requirements		20	L	
Altitude		11	label	13
Ambient Temperature		11	load capability	
	C		rotary union	19
cleaning			lubrication	
collet/collet chuck		40	collet/collet chuck	40
mounting surface		17	Lubrication	40
solvents		40	M	
Cleaning		40	maintenance	39
collet/collet chuck			mounting surface	
cleaning		40	cleaning	17
lubrication		40	securing stage	17
compressed air		20	N	
	D		nitrogen	20
Directive 2006/42/EC		7	P	
	E		part number	13
Electrical Specifications			Performance Specifications	
S-130		34	S-130	34
S-76		33	S-76	33
EN 60204-1 2010		7	piston seal replacement	42
EN ISO 12100 2010		7	pressure vessel length/weight limits	19
Encoder Specifications		32	Protection Rating	11
	F		protective ground connection	28
field service		39	R	
			ringseal o-ring replacement	42

Rotary Motor Specifications	33
rotary union	
load capability	19
pressure vessel length/weight limits	19
S	
S-130	
Electrical Specifications	34
Performance Specifications	34
S-76	
Electrical Specifications	33
Performance Specifications	33
S-76-35	33
seal replacement	42
serial number	13
service schedule	39
shimming	17
stabilizing stage	13
stage	
distortion	17
stabilizing	13
Support	2
T	
Technical Support	2
Thermistor Specifications	32
V	
Vibration	11
W	
Warranty and Field Service	55
Wet Cut Fluid Requirements	20
wet cut rotary union removal	47
wet cut rotary union seal replacement	44