



Laser Machining System

LaserTurn160



Maximum Throughput, Minimum Error Motion

LaserTurn®160 is the most capable and effective cylindrical laser machining motion platform available. Optimized to provide the most precise motion trajectories with ultra-high dynamic performance, LaserTurn160 can improve your process throughput by 40% or more compared to similar cylindrical machining systems. Rotary axis options meet your exact needs, so you can process tubes up to 7.9 mm diameter with our versatile CCS130DR rotary stage or achieve speeds and accelerations up to 3000 rpm and accelerations up to 8000 rad/s² with our high-dynamic ASR1300 rotary stage. Both options are compatible with Type-D collets and an optional front gripper mechanism, so you'll easily process tubes of nearly any length. Ideal for machine builders, system integrators, contract manufacturers and end-users, LaserTurn160's advanced performance capabilities help you to manufacture greater volumes of highly reproducible parts in less time.

Key Applications

The LaserTurn160 is ideal for these applications:

- ◆ Medical device manufacturing
- ◆ Stent cutting
- ◆ Catheter, guidewire & other hypotube manufacturing
- ◆ Cylindrical laser machining

KEY FEATURES:

- ◆ Increases **PROCESS THROUGHPUT UP TO 40% OR MORE** with NEW high-dynamic rotary axis option
- ◆ Dead-length, pneumatically actuated collet **MINIMIZES TUBE MOTION** during gripping & regripping
- ◆ Optional alignment gripper enables **REPEATABLE TUBE ADVANCE** for easily processing longer tubes
- ◆ Accommodates tube diameters from 0.1 mm to 7.9 mm
- ◆ Direct-drive motors & crossed-roller bearings deliver **ULTRA-SMOOTH MOTION** for manufacturing highly reproducible parts

LASERTURN160 SPECIFICATIONS

Mechanical Specifications	LaserTurn160 <i>LINEAR AXIS</i>	LaserTurn160 <i>CCS ROTARY AXIS</i>	LaserTurn160 <i>ASR ROTARY AXIS</i>
Travel	100 mm	Continuous	Continuous
Accuracy-Calibrated⁽¹⁾	±0.5 µm	±2.5 arc sec	± 2.5 arc sec
Bidirectional Repeatability	±0.2 µm	±1 arc sec	±1 arc sec
Horizontal Straightness	±1.5 µm	N/A	N/A
Vertical Straightness	±1.5 µm	N/A	N/A
Pitch	10 arc sec	N/A	N/A
Roll	10 arc sec	N/A	N/A
Yaw	5 arc sec	N/A	N/A
Maximum Speed⁽²⁾	350 mm/s	1000 rpm	3000 rpm (-HS) 1000 rpm (-SS)
Maximum Acceleration	1 g	4600 rad/s ² peak 1200 rad/s ² continuous	8000 rad/s ² peak 3300 rad/s ² continuous
Tube Capacity	N/A	∅ 7.9 mm (Dry Cut) ∅ 3.0 mm (Wet Cut) (3)	∅ 4.0 mm
Collet Type⁽⁴⁾	N/A	Levin Type D	Levin Type D
Collet Runout⁽⁵⁾	N/A	<30 µm	<25 µm
Load Capacity - Axial⁽⁶⁾	2 kg		
Load Capacity - Radial⁽⁶⁾	0.5 kg		
Moving Mass (Unloaded)	4.7 kg (-ASR) 5.0 kg (CCS)		
Rotor Inertia (Unloaded)	N/A	.00033 kg·m ²	0.00014 kg·m ²
Mass⁽⁷⁾	11.5 kg (-ASR) 11.8 kg (-CCS)		
Minimum System Air Pressure⁽⁸⁾	N/A	100 psig	100 psig
Material	Anodized Aluminum, Stainless Steel		

Notes:

1. When configured with -PL2 metrology option.
2. Maximum speed based on stage capability. Requires selection of appropriate amplifier with sufficient voltage and current.
3. Maximum tube diameter is 6.7 mm when dry-cutting with the wet-cut configuration.
4. Collet chuck accepts Levin Type D collets.
5. Measured TIR of precision gage pin chucked with an ultra-precision Type D collet 3 mm away from collet face at 100 psig applied air pressure and no load.
6. Maximum loads are mutually exclusive. Contact factory if part load requirements exceed specifications.
7. When configured with the -FT1 tooling option. Alignment gripper options add 0.3 kg.
8. Collet chuck mechanism is normally open and requires air supply to close. Air supply must be dry and oil-free, or must be 99.99% pure nitrogen. Air or nitrogen must be filtered to 1 µm particle size or finer.

LASERTURN160 ORDERING OPTIONS

Rotary Axis (Required)

- CCS CCS130DR-160 direct-drive rotary collet stage, holds up to 7.9 mm dia. workpiece
- ASR ASR1300 direct-drive rotary collet stage, high dynamics, holds up to 4.0 mm dia. workpiece

Rotary Speed (Required)

- SS Standard speed
- HS High speed (available only with -ASR option)

Cutting Configuration (Required)

- DCUT Dry cutting configuration
- WCUT Wet cutting configuration with fluid rotary union (available only with -CCS option)

Front Tooling Options (Required)

- FT1 Front tooling platform, metric
- FT2 Front tooling platform, metric, with gripper
- FT3 Front tooling platform, metric, with right-hand alignment gripper
- FT4 Front tooling platform, metric, with left-hand alignment gripper

Metrology, Linear (Required)

- PL1 Linear metrology, uncalibrated, with performance plots
- PL2 Linear metrology, calibrated with performance plots

Metrology, Rotary (Required)

- PL0 No performance plots
- PL2 Rotary metrology, calibrated with performance plots

Integration (Required)

Aerotech offers both standard and custom integration services to help you get your system fully operational as quickly as possible. The following standard integration options are available for this system. Please consult Aerotech if you are unsure what level of integration is required or if you desire custom integration support with your system.

- TAS **Integration - Test as system**
Testing, integration and documentation of a group of components as a complete system that will be used together (ex: drive, controller and stage). This includes parameter file generation, system tuning and documentation of the system configuration.
- TAC **Integration - Test as components**
Testing and integration of individual items as discrete components. This is typically used for spare parts, replacement parts or items that will not be used or shipped together (ex: stage only). These components may or may not be part of a larger system.

LASERTURN160 ORDERING OPTIONS

Accessories (to be ordered separately)

Collet-D-CLTxx Levin Type D collet, 0.1 mm to 7.9 mm part diameter sizes available

RingSeal-D-RSxx Ring seal for wet cutting - consult Aerotech for available sizes

CGF [Collet and Gripper Filtration Kit](#)

LASERTURN160 SPECIFICATIONS

Peak Following Error vs. Motion Cycle Time

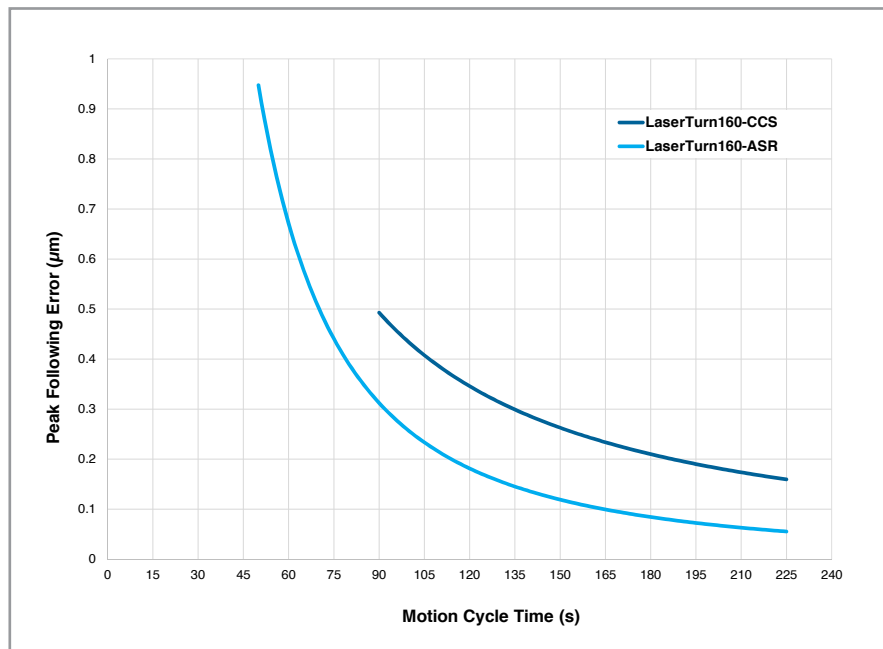

LaserTurn160 is capable of achieving extremely high processing speeds with excellent contouring performance. Characterized by contouring a typical cardiovascular stent profile with a diameter of 1.9 mm and a length of 28.5 mm, and when paired with our powerful Automation1 controller, achieving the ideal balance of throughput and precision has never been easier.

LASERTURN160 DIMENSIONS

LASERTURN160-CCS

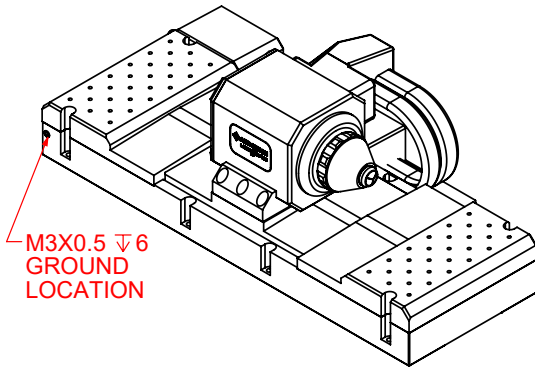

M3X0.5 ∇ 6
GROUND
LOCATION

LASERTURN160-CCS
(LASERTURN160-CCS-SS-DCUT-FT1 SHOWN)

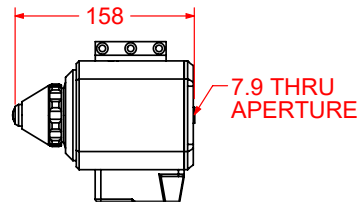

CCS-DCUT ROTARY

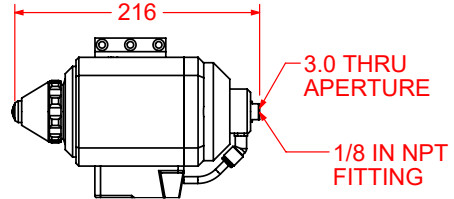

CCS-WCUT ROTARY

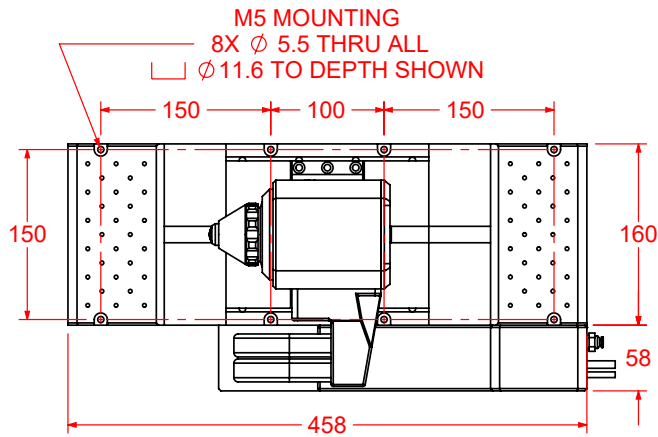

M5 MOUNTING
8X ϕ 5.5 THRU ALL
 \lrcorner ϕ 11.6 TO DEPTH SHOWN

COLLET
(NOT INCLUDED
WITH STAGE)

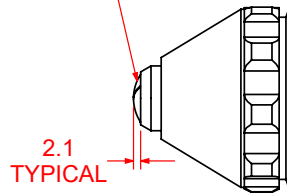

2.1
TYPICAL

FIXED LENGTH, NORMALLY OPEN
COLLET MECHANISM (SHOWN CLOSED)
DETAIL A
SCALE 1:2

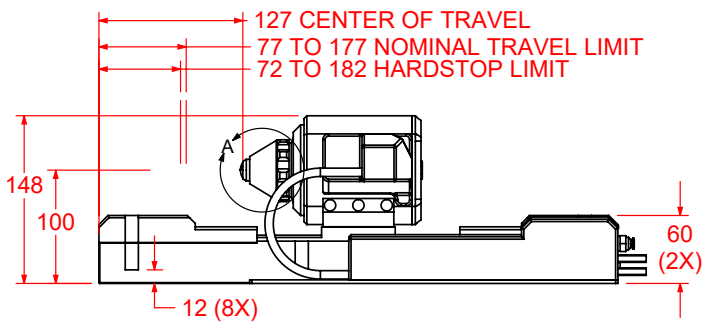

127 CENTER OF TRAVEL
77 TO 177 NOMINAL TRAVEL LIMIT
72 TO 182 HARDSTOP LIMIT

STAGE MOTOR/
FEEDBACK CABLES
1M LENGTH

COLLET CHUCK
AIR INLET, 4MM HOSE

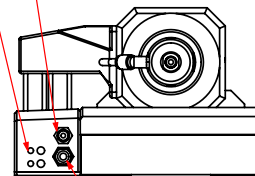

WATER INLET
6MM HOSE
(-WCUT ONLY)

DIMENSIONS: MILLIMETERS

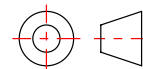

LASERTURN160 DIMENSIONS

LASERTURN160-ASR

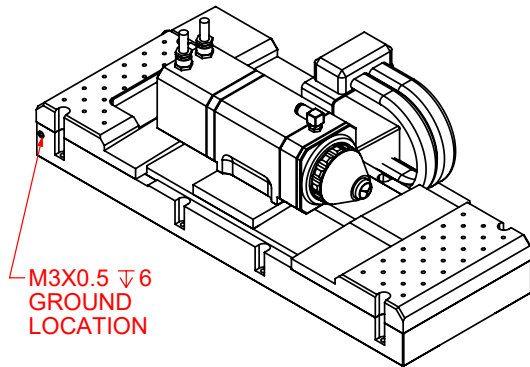

M3X0.5 ∇ 6
GROUND
LOCATION

LASERTURN160-ASR

(LASERTURN160-ASR-SS-DCUT-FT1 SHOWN)

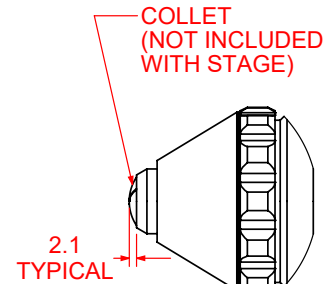
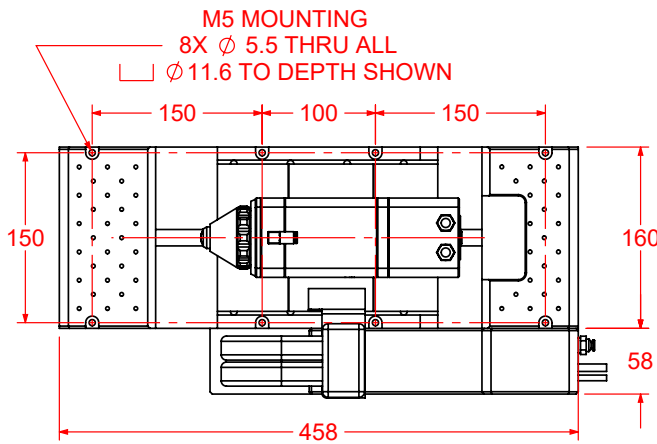
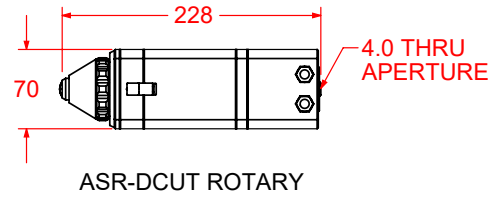

FIXED LENGTH, NORMALLY OPEN
COLLET MECHANISM (SHOWN CLOSED)
DETAIL B
SCALE 1 : 2

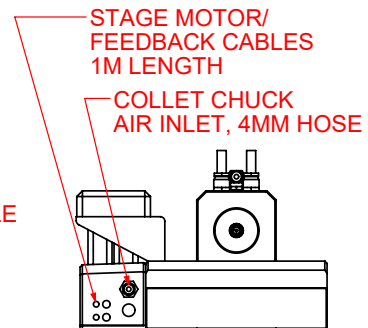
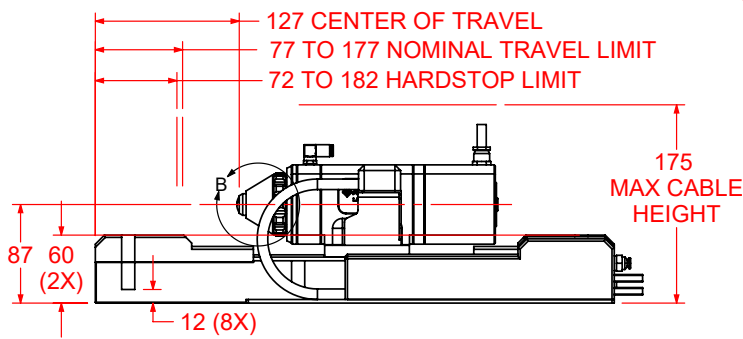

DIMENSIONS: MILLIMETERS

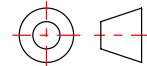

LASERTURN160 DIMENSIONS

LASERTURN160 TOOLING PLATFORM OPTIONS

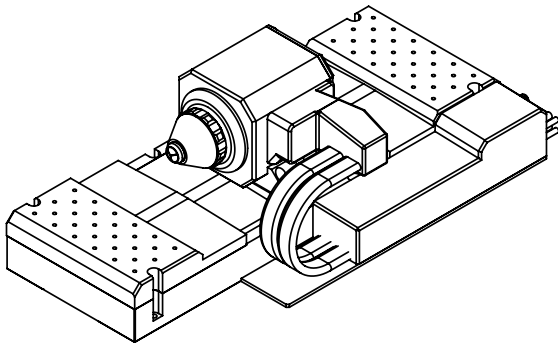

-FT1 TOOLING PLATFORM
(LASERTURN160-CCS-SS-DCUT-FT1 SHOWN)

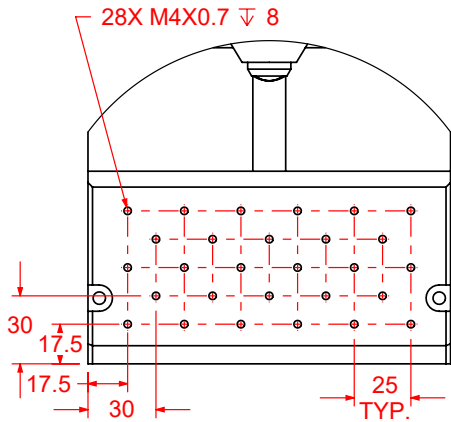
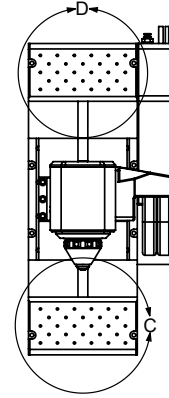

DETAIL C
SCALE 1 : 3

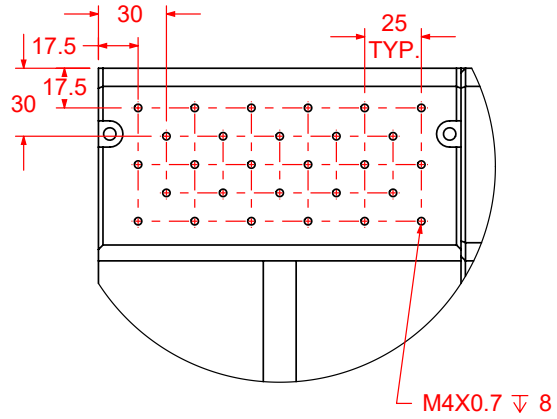

DETAIL D
SCALE 1 : 3

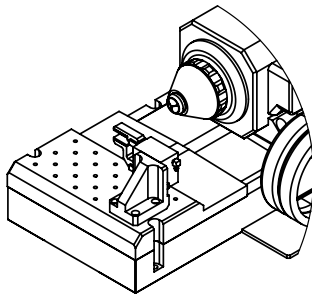

-FT2 TOOLING PLATFORM
(LASERTURN160-CCS-SS-DCUT-FT2 SHOWN)

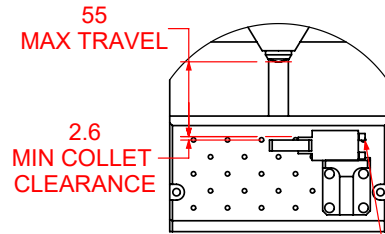
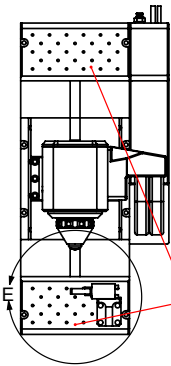

DETAIL E
SCALE 1 : 5

GRIPPER AIR INLET
2X 4MM HOSE

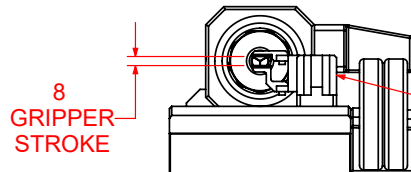

DIMENSIONS: MILLIMETERS

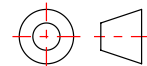

LASERTURN160 DIMENSIONS

LASERTURN160 TOOLING PLATFORM OPTIONS

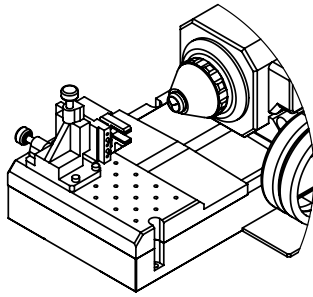

-FT3 TOOLING PLATFORM
(LASERTURN160-CCS-SS-DCUT-FT3 SHOWN)

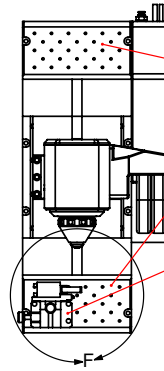

SEE -FT1 FOR MOUNTING PATTERN

-FT3 SHOWN. GRIPPER ON OPPOSITE SIDE FOR -FT4 OPTION. SEE ISOMETRIC VIEW.

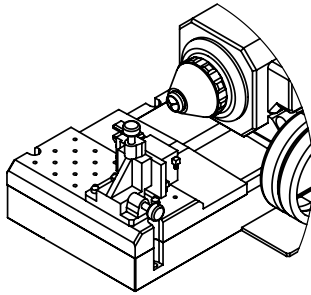

-FT4 TOOLING PLATFORM
(LASERTURN160-CCS-SS-DCUT-FT4 SHOWN)

GRIPPER AIR INLET
2X 4MM HOSE

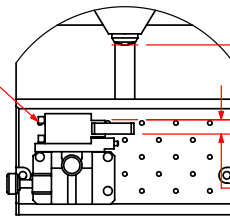

55
MAX TRAVEL

10.6
MIN COLLET CLEARANCE

TYP. FOR -FT3 AND -FT4
DETAIL F
SCALE 1 : 5

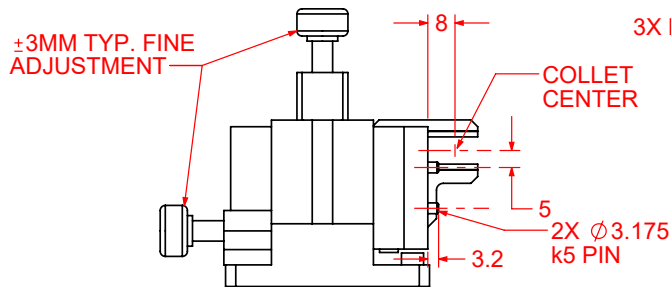

GRIPPER ACCESSORY MOUNT
LASERTURN160-CCS WITH -FT3/-FT4

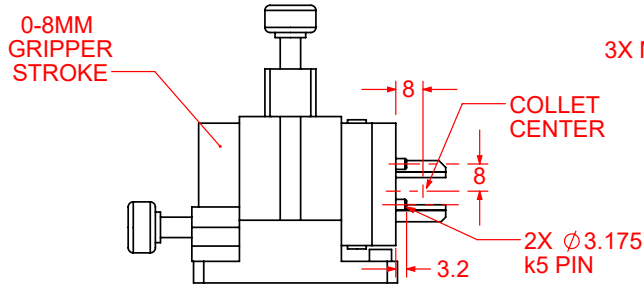
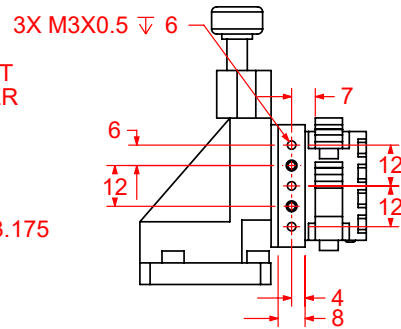

GRIPPER ACCESSORY MOUNT
LASERTURN160-ASR WITH -FT3/-FT4

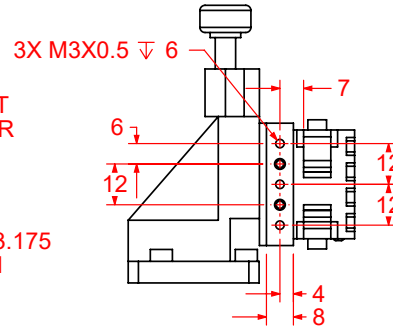

DIMENSIONS: MILLIMETERS

